

3x400V+N+PE/16A

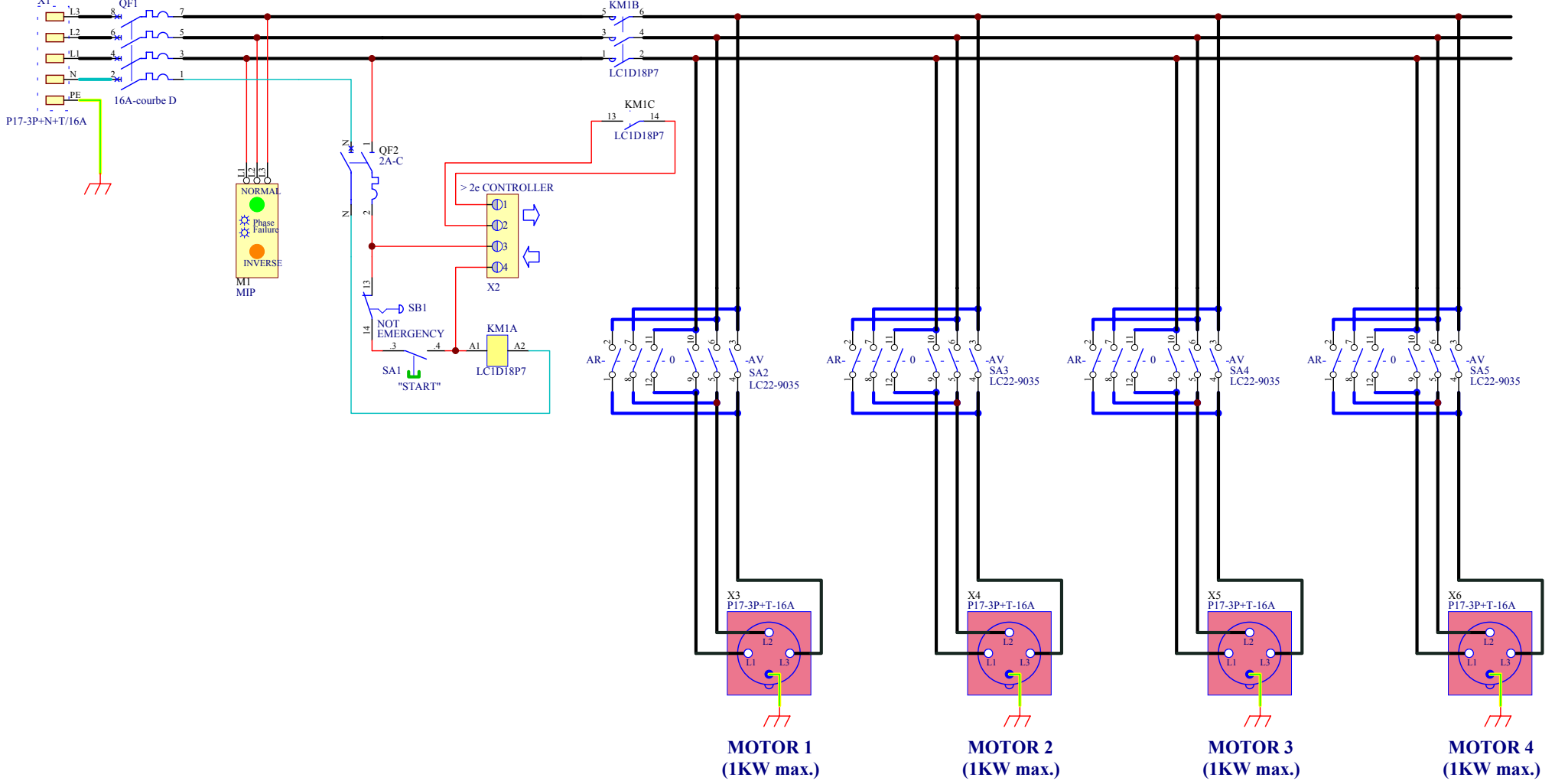

**MOTOR 1
(1KW max.)**

**MOTOR 2
(1KW max.)**

**MOTOR 3
(1KW max.)**

**MOTOR 4
(1KW max.)**

Title			4 CHANNEL CONTROLLER WITHOUT REMOTE		
Size	Number			Revision	
A3	SC4P			Plan n°03_106	
Date:	17-Mar-2003	Sheet 1 of 1			
File:	D:\APPL\SC4P\SC4P_2.SCH	Drawn By:	VS		

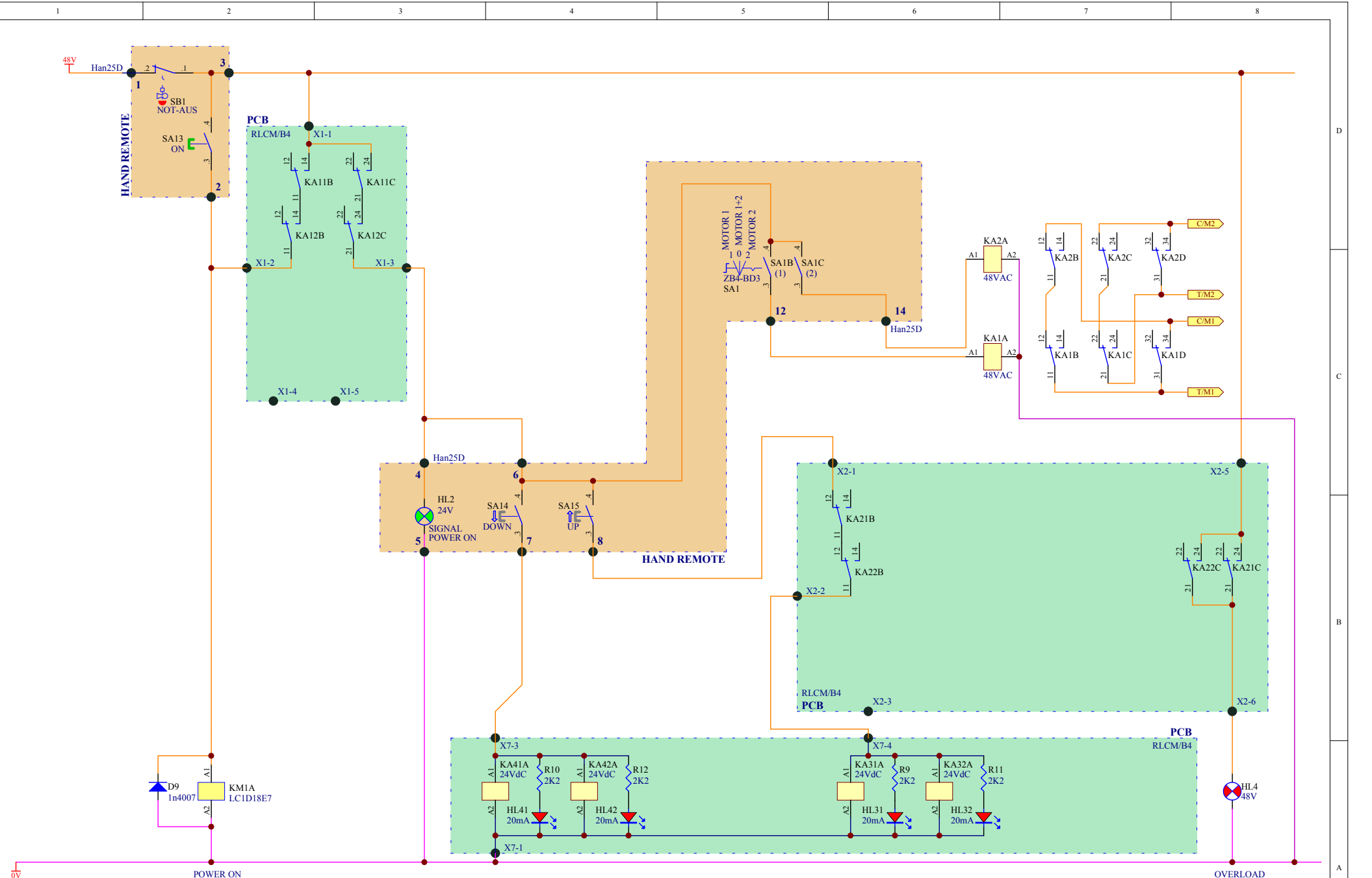

Title		
2 CHANNEL CONTROLLER FOR HOISTS Version D (CONTROL CIRCUIT)		
Size	Number	Revision
A3	B2PRMLV-C1	Plan n°03_175
Date:	7-Apr-2003	Sheet1 of 1
File:	D:\APPL1\B2PRML-1\B2LV_C2.SCH	Drawn By: VS

POWER SUPPLY
3x410V+PE/16A

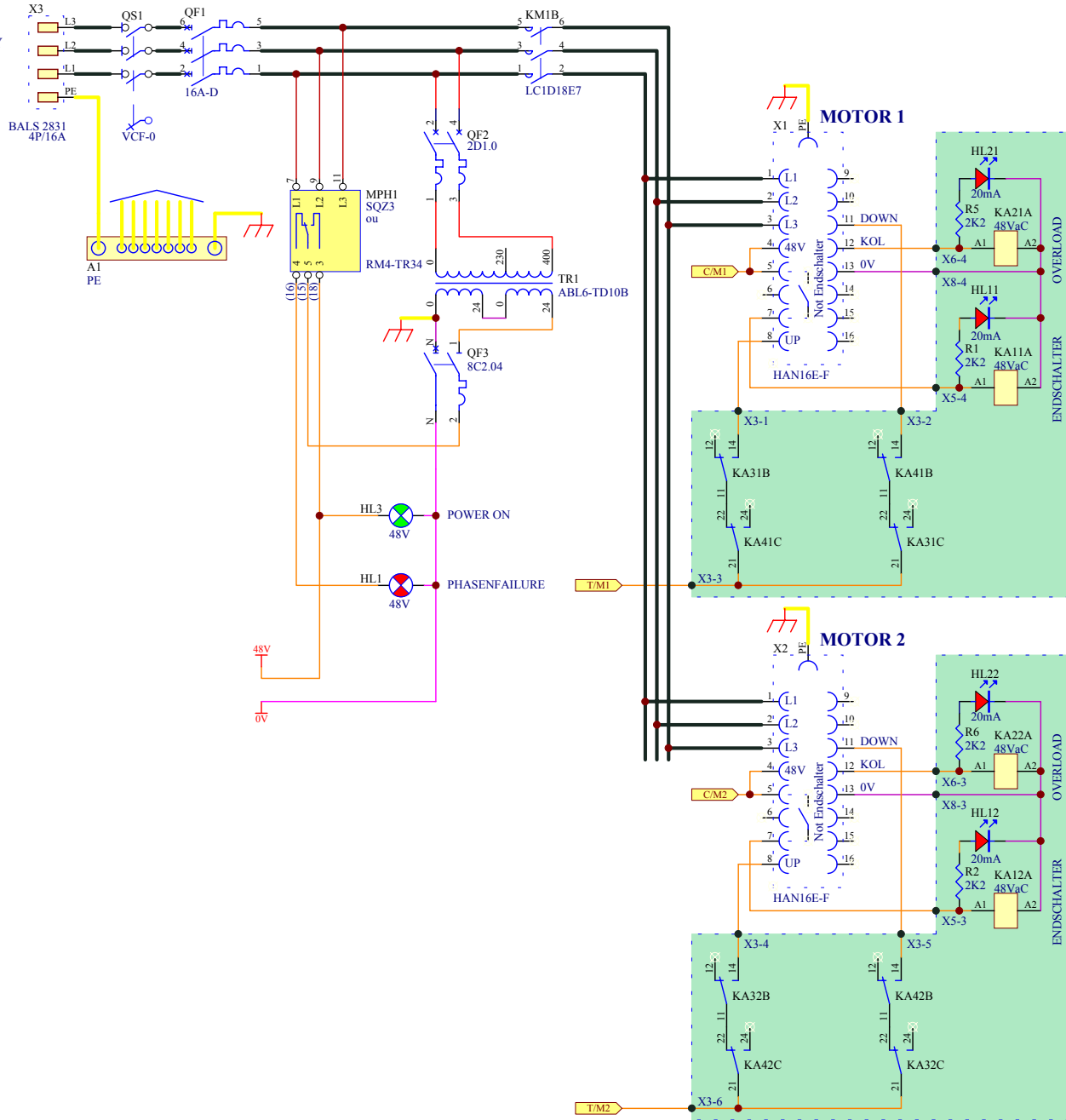

Title			
2 CHANNEL CONTROLLER FOR HOISTS Version D (POWER CIRCUIT)			
Size	Number	Revision	
A3	B2PRMLV-C1	Plan n°03_174	
Date:	7-Apr-2003	Sheet	1 of 1
File:	D:\APPL1\B2PRML-1\B2LV_P2.SCH	Drawn By:	VS

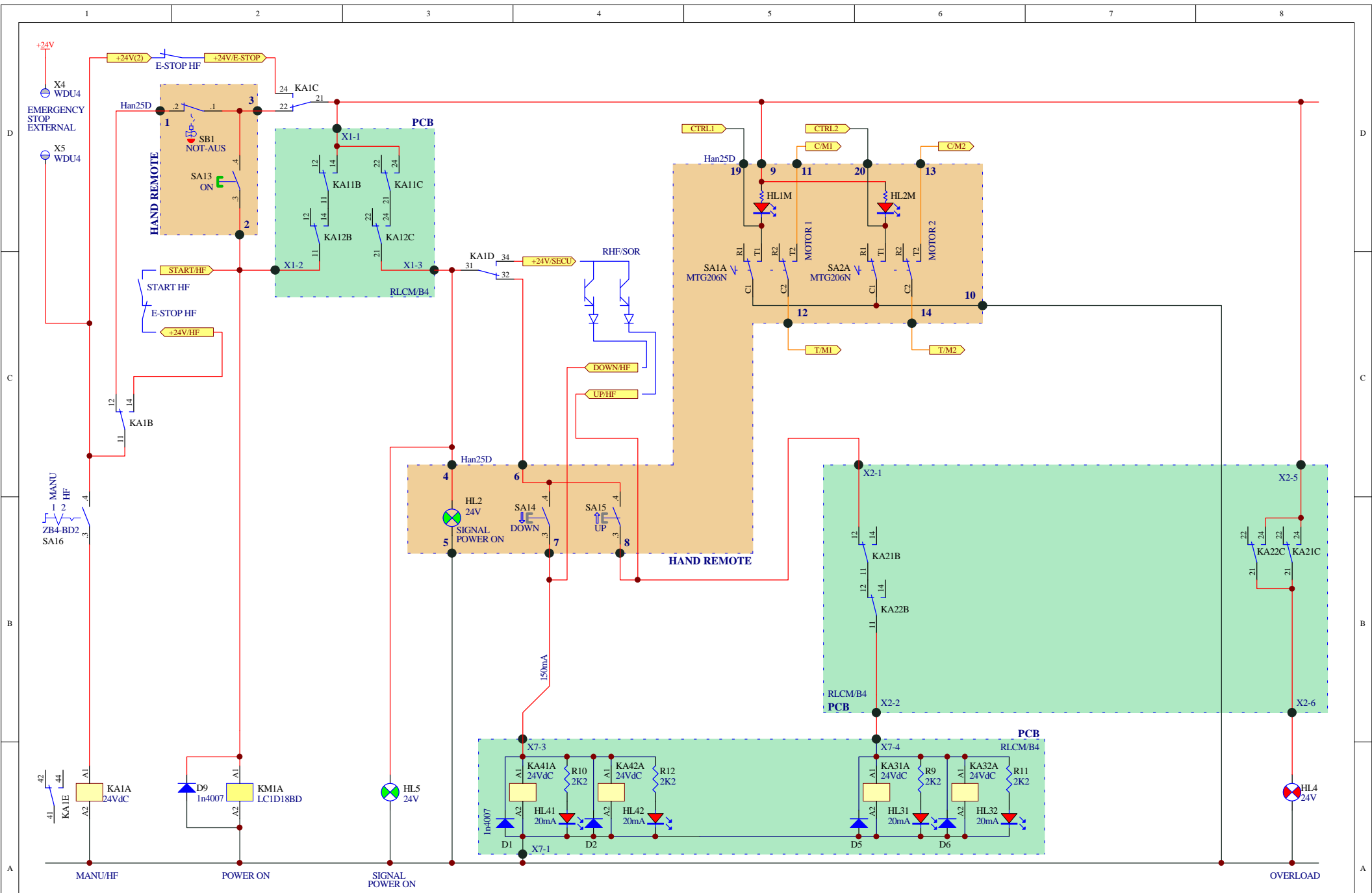

Title		CONTROLLER 2 MOTOREN mit HF (CONTROL CIRCUIT)	
Size	Number	Revision	Plan n°03_051
A3	B2PRMLV-C1/SR		
Date:	17-Feb-2003	Sheet	1 of 1
File:	D:\APPL\B2PRML-1\B2LVSR_C.SCH	Drawn By:	VS

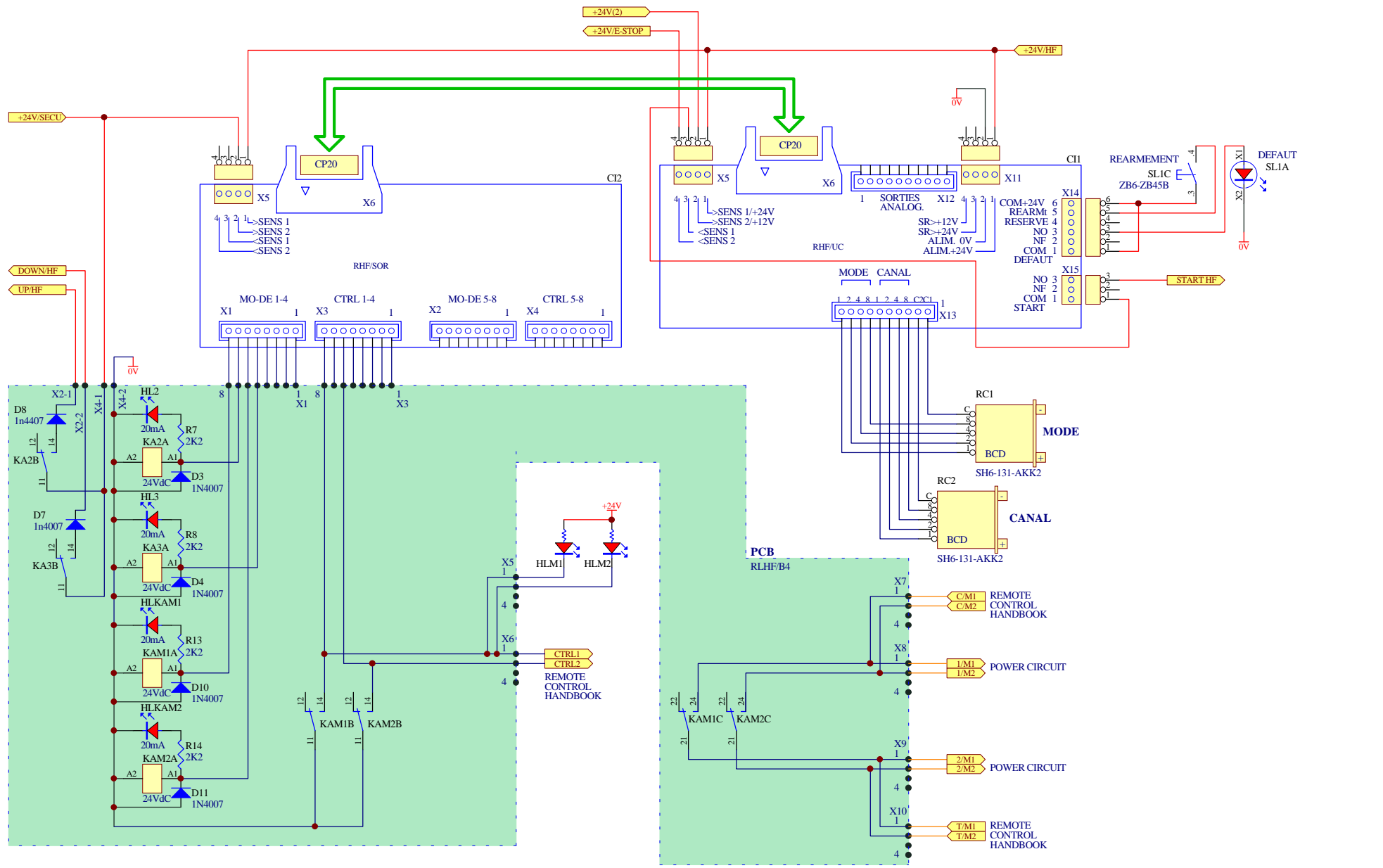

Title		CONTROLLER 2 MOTOREN mit HF (HF RECEIVER)	
Size	Number	Revision	Plan n°03_052
A3	B2PRMLV-C1/SR		
Date:	14-Feb-2003	Sheet	1 of 1
File:	D:\APPL1\B2PRML-1\B2LVSR_R.SCH	Drawn By:	VS

NETZANSCHLUSS
3x410V+PE/16A

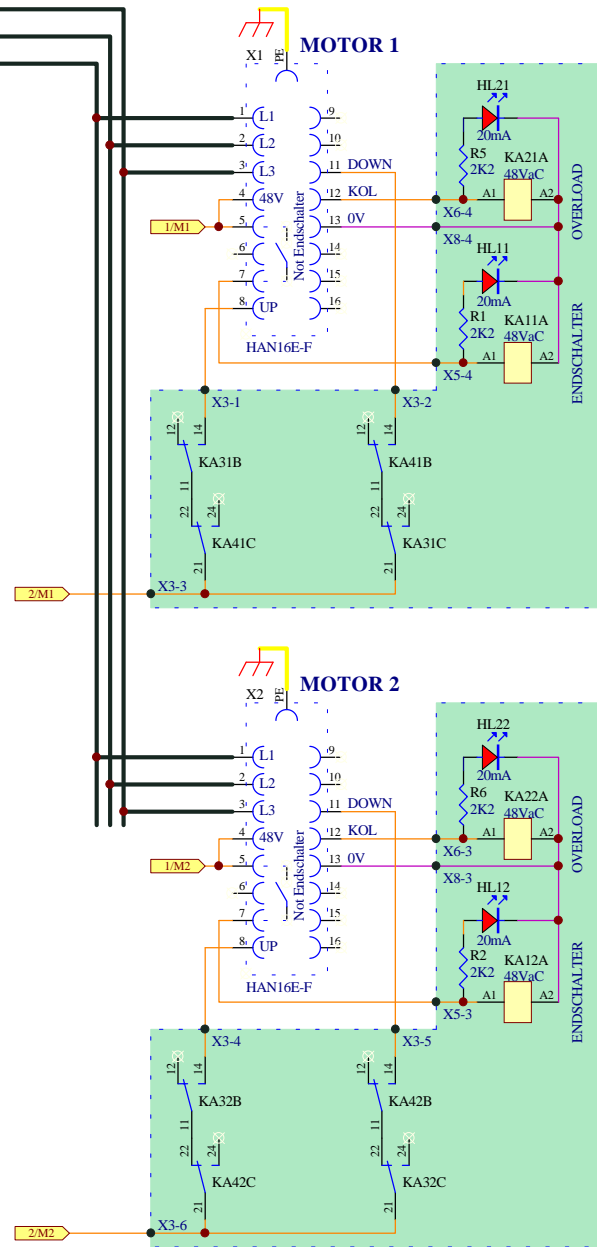
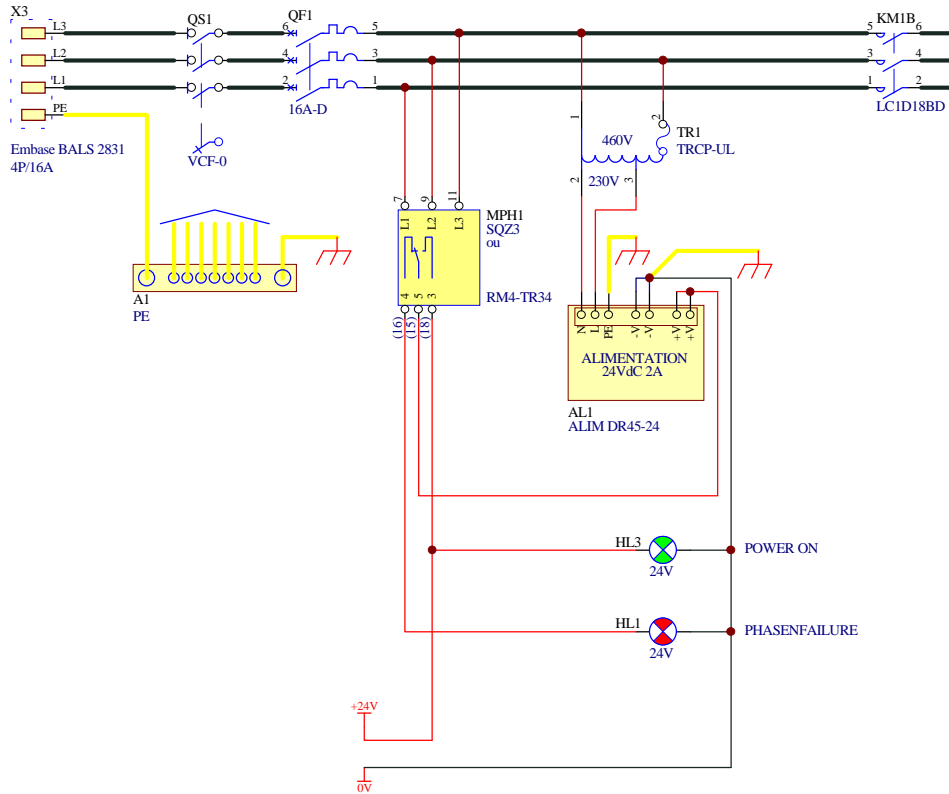

Title			CONTROLLER 2 MOTOREN mit HF (POWER CIRCUIT)	
Size	A3	Number	B2PRMLV-C1/SR	
Date:	14-Feb-2003	Sheet	of 1	
File:	D:\APPLI\B2PRML-1\B2LVSR_P.SCH	Drawn By:	VS	

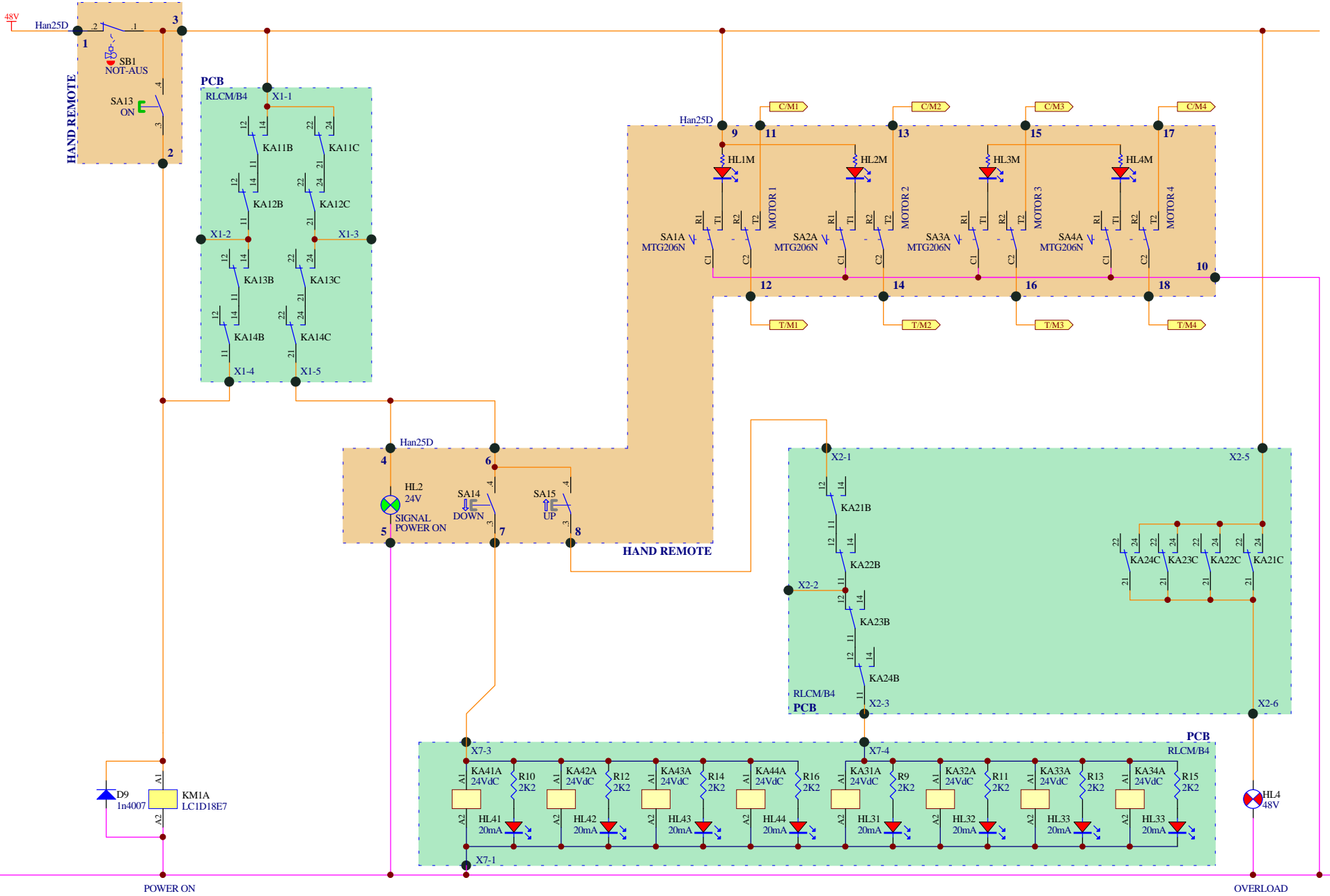

Title			CONTROLLER 4 MOTOREN mit HF (CONTROL CIRCUIT)		
Size	Number	Revision		Plan n°03_057	
A3		B4PRMLV-C1			
Date:	17-Feb-2003	Sheet	1 of 1		
File:	D:\APPL\B4PRML-1\B4LV_C.SCH	Drawn By:	VS		

POWER SUPPLY
3x400V+N+PE/16A

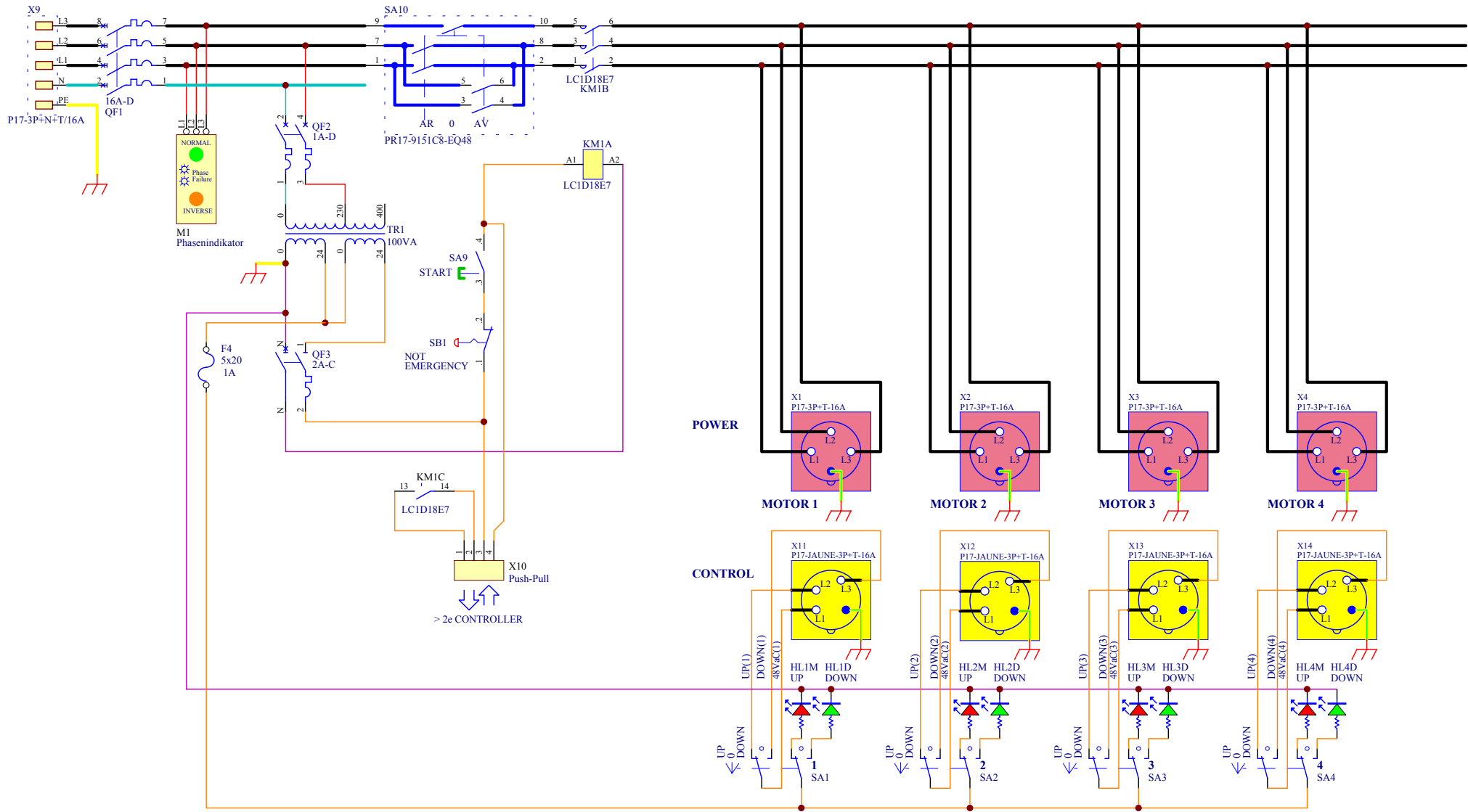

Title 4 CHANNEL CONTROLLER 19" WITHOUT REMOTE FOR HOISTS WITH INTERNALS CONTACTORS		
Size A3	Number FL4PLV	Revision Plan n°03_149 replace n°01_332
Date: 2-Apr-2003	Sheet 1 of 1	
File: D:\APPLI\FL4PLV\FL4PLV 2.SCH	Drawn By: VS	

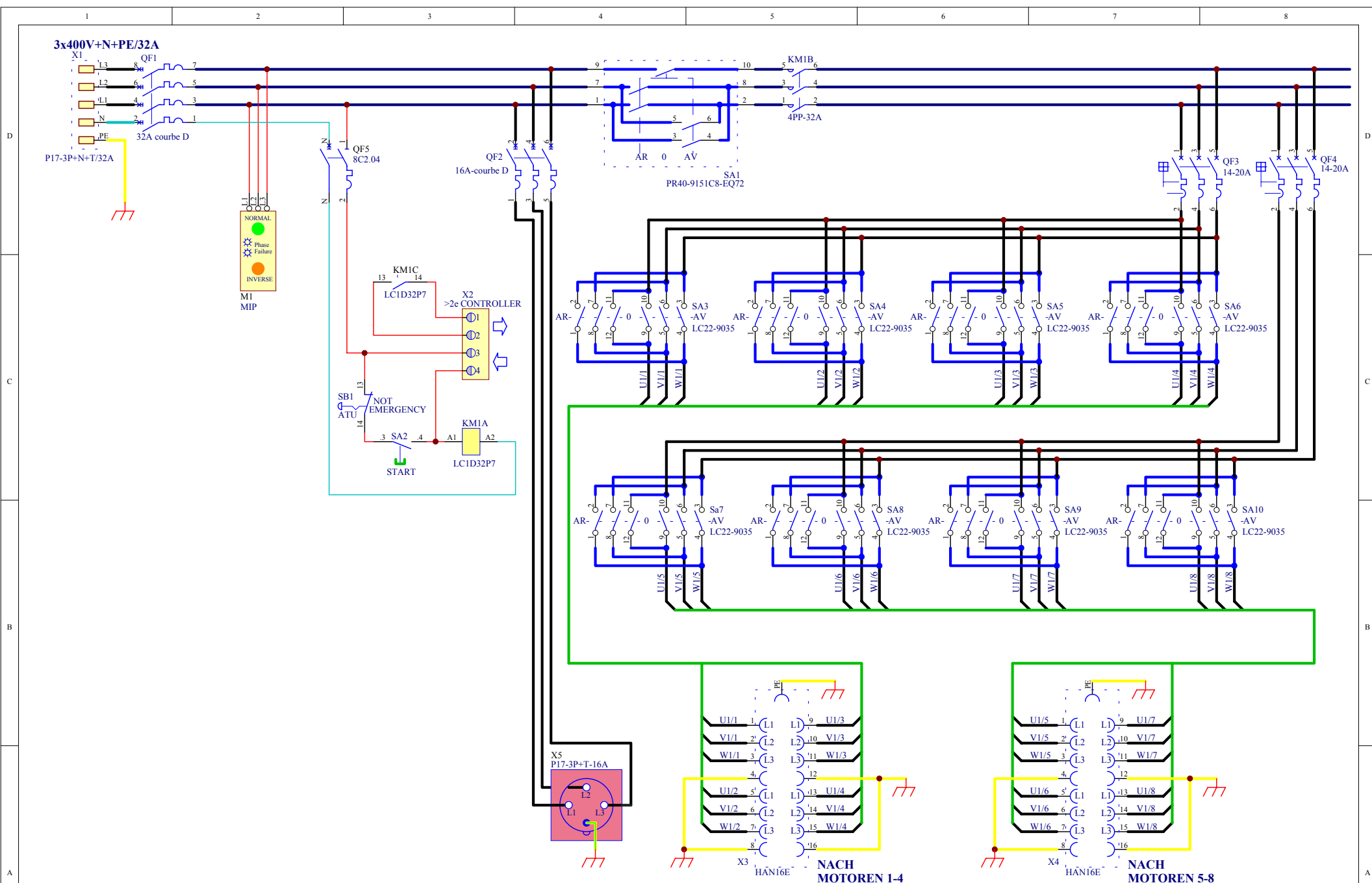

Title			8 CHANNEL CONTROLLER WITHOUT REMOTE
Size	Number	Revision	
A3	FL8P	Plan n°03_140	
Date:	31-Mar-2003	Sheet 1 of 1	Drawn By: VS
File:	D:\APPLI\FL8P\FL8P 2.SCH		

POWER SUPPLY
3x400V+N+PE/32A

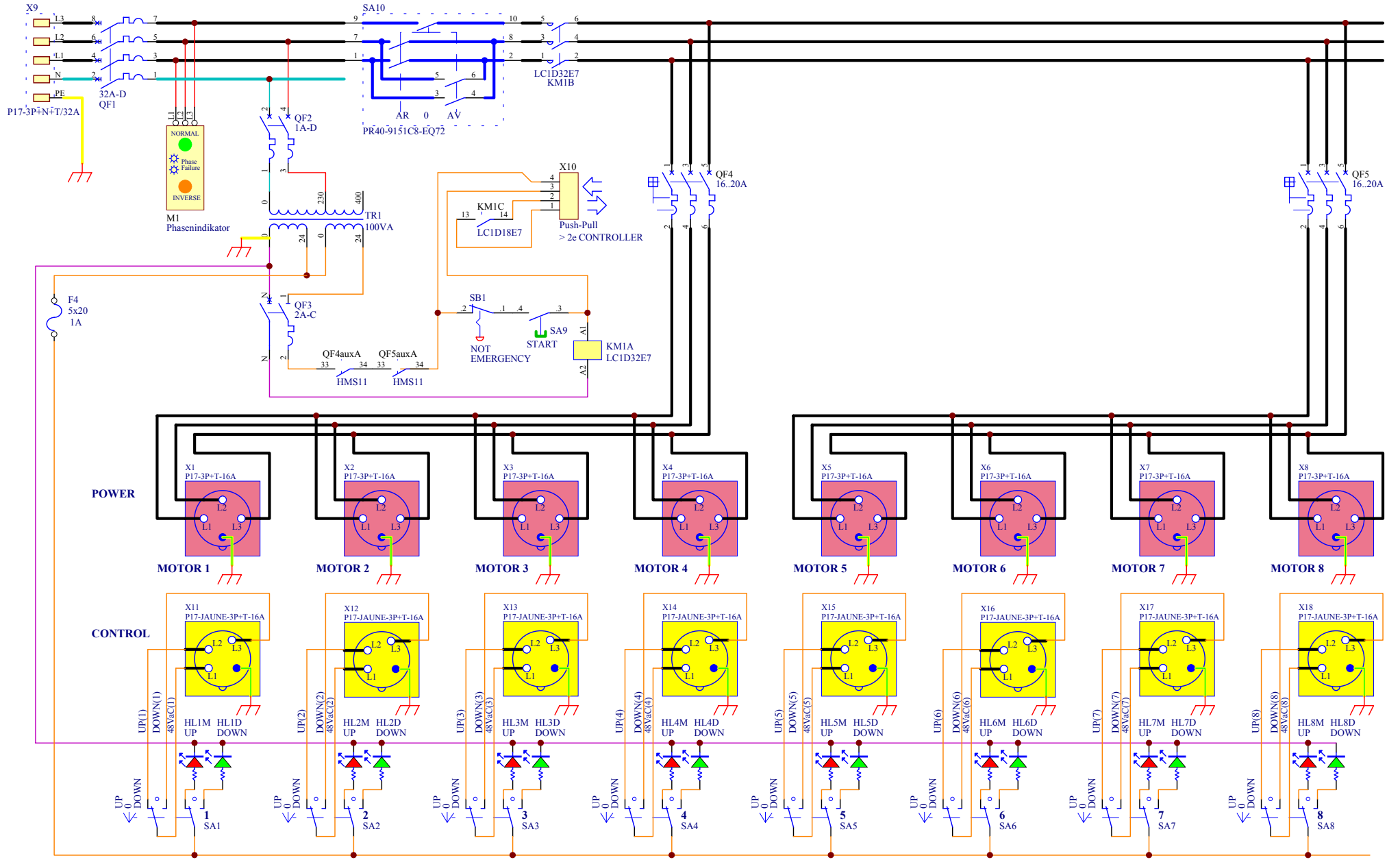

Title 8 CHANNEL CONTROLLER 19" WITHOUT REMOTE FOR HOISTS WITH INTERNALS CONTACTORS		
Size A3	Number FL8PLV	Revision Plan n°03_147 replace n°02_197
Date: 2-Apr-2003	Sheet1 of 1	
File: D:\APPLI\FL8PLV\FL8PLV.SCH	Drawn By: VS	

3x400V+N+PE/32A

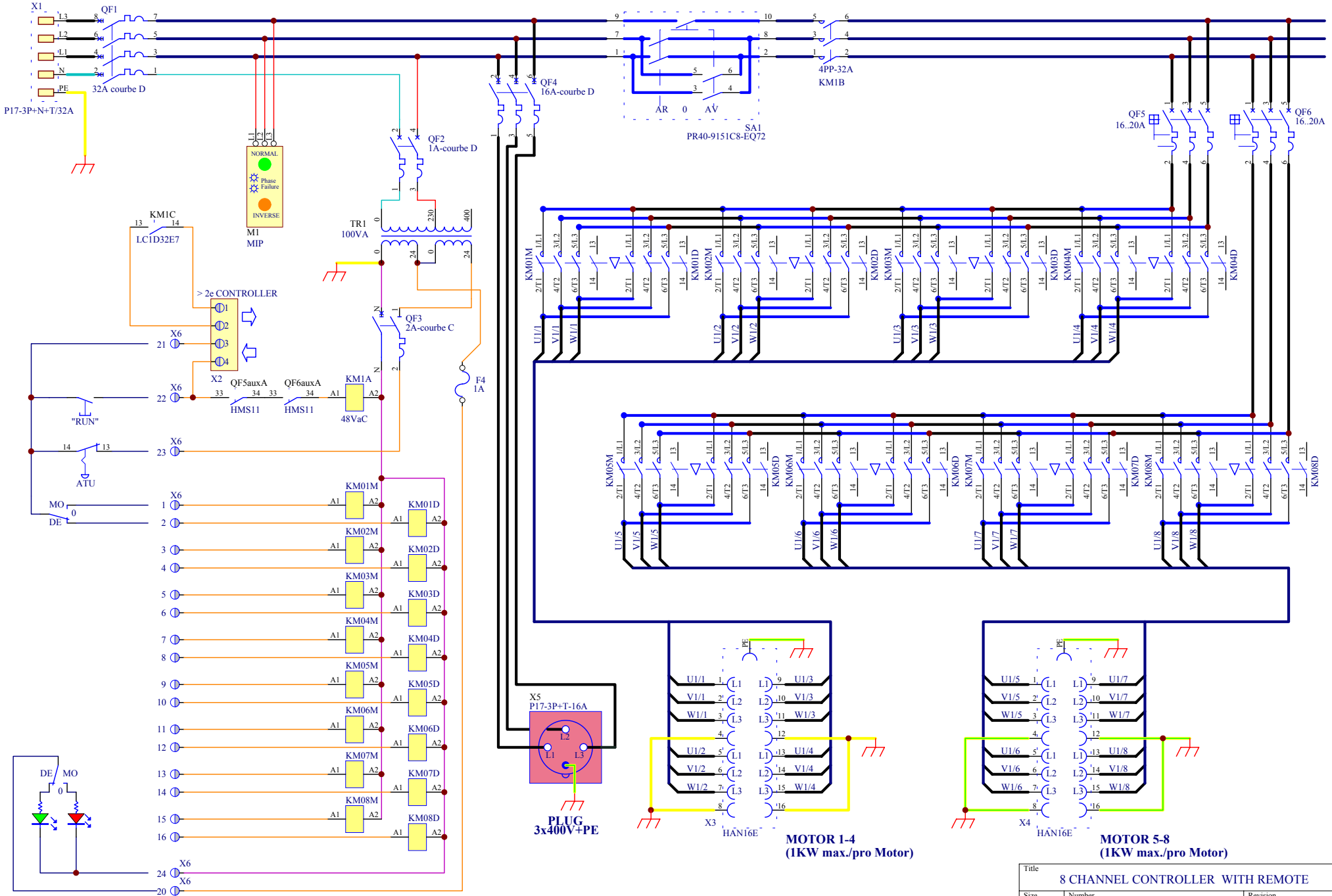

Harting HAN25D (09-21-025-3101)

Title		
8 CHANNEL CONTROLLER WITH REMOTE		
Size	Number	Revision
A3	FL8PRM	Plan n°03_142 remplace n°00_199
Date:	1-Apr-2003	Sheet 1 of 1
File:	D:\APPLI\FL8PRM\FL8PRM_2.SCH	Drawn By: VS

POWER SUPPLY
3x400V+N+PE/32A

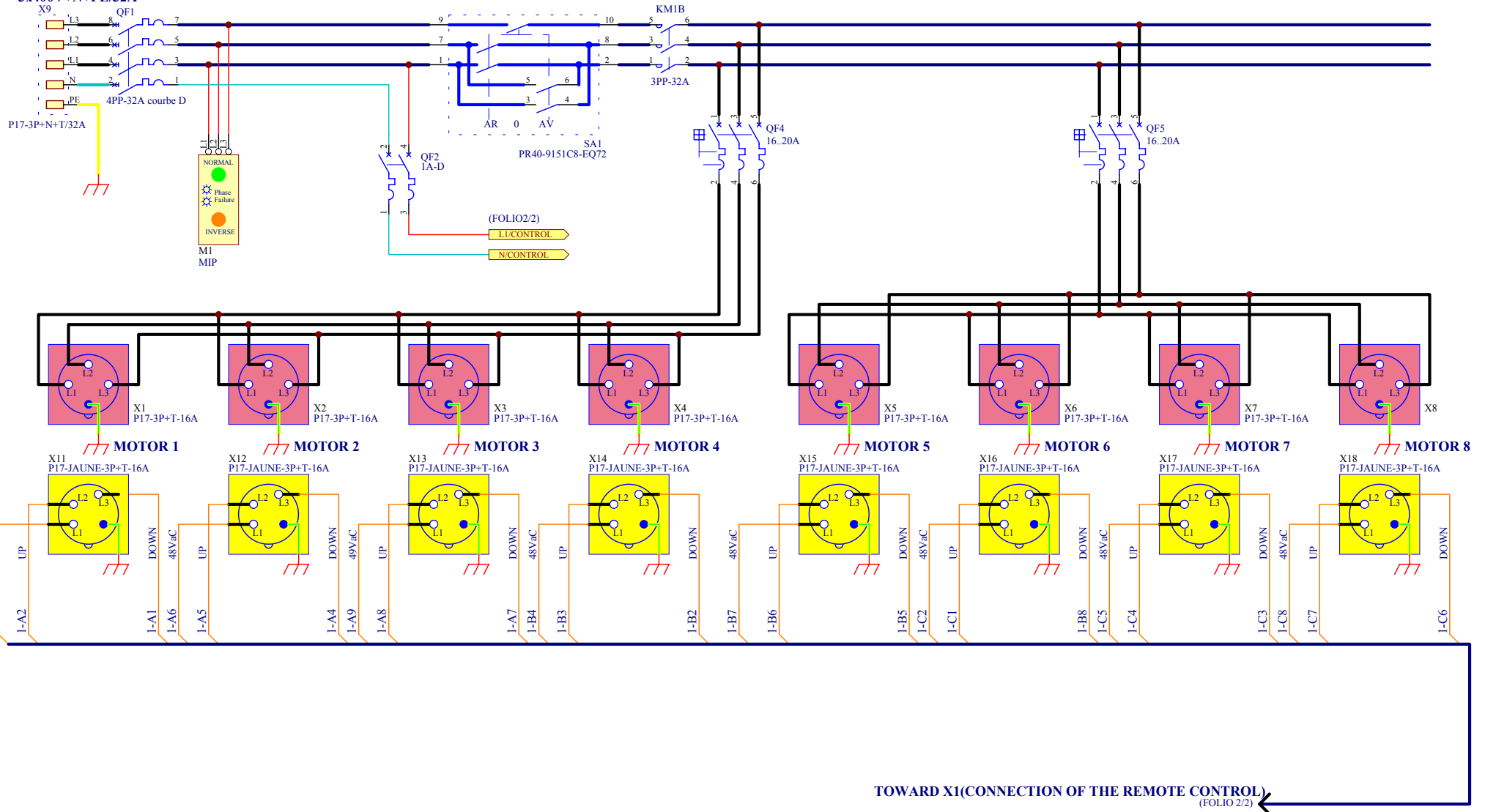

TOWARD X1(CONNECTION OF THE REMOTE CONTROL)
(FOLIO 2/2)

Title			
8 CHANNEL CONTROLLER 19" WITH REMOTE FOR HOISTS WITH INTERNALS CONTACTORS (POWER CIRCUIT)			
Size	Number	Revision	
A3		Plan n°02_262	
Date:	3-Apr-2003	Sheet 1 of 2	
File:	D:\APPLI\FI8PRMLV\F8PRMLVP.SCH	Drawn By:	VS

EN CAS DE MISE EN PARALLELE DE PLUSIEURS CONTROLERS, L'ARRET D'URGENCE PRINCIPAL EST CELUI DE LA TELECOMMANDE MAITRE BRANCHER LA PREMIERE TELECOMMANDE DE OUT vers IN DE LA SUIVANTE, etc.

L1/CDE(FOLIO 1/2)
N/CDE(FOLIO 1/2)

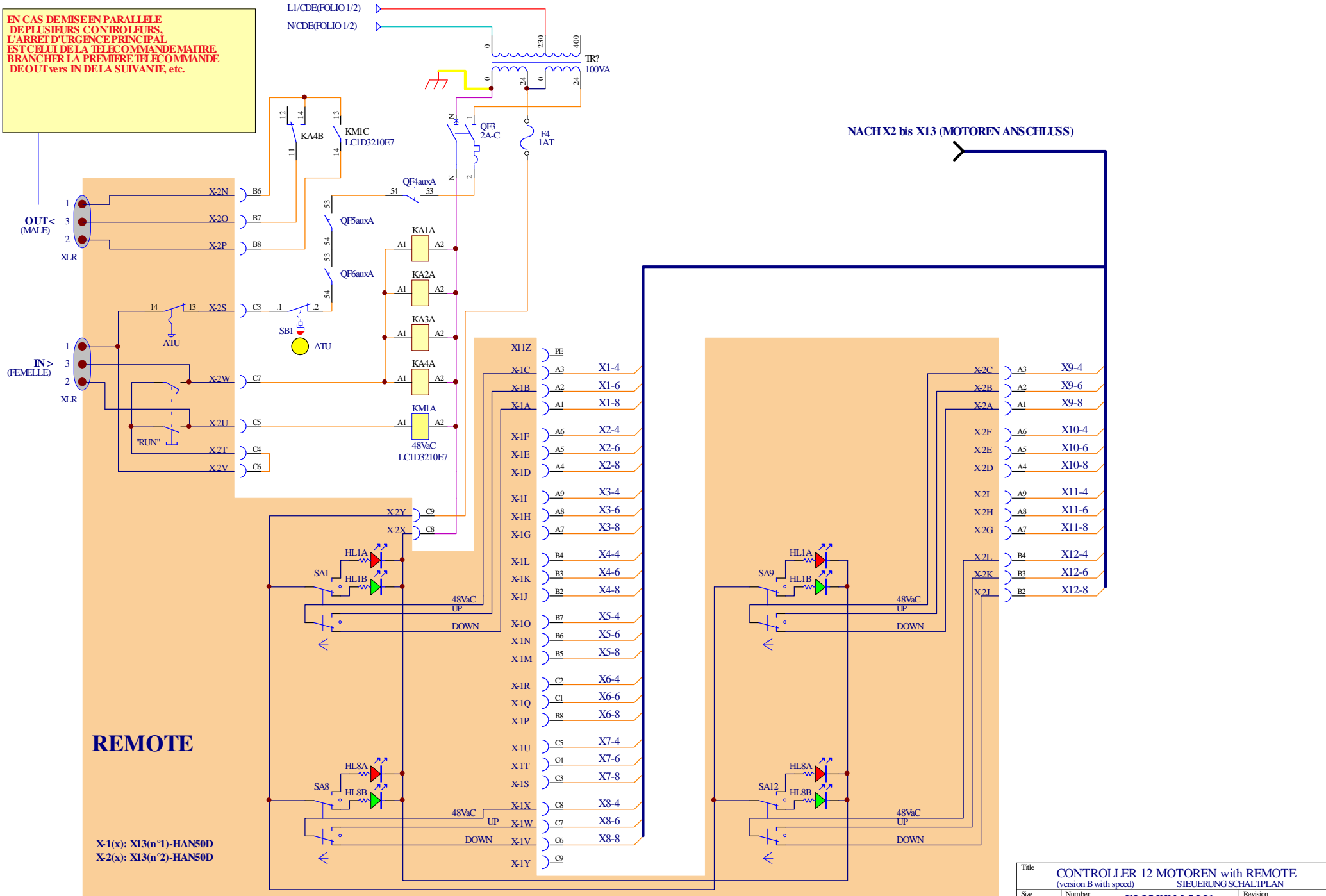

NACH X2 bis X13 (MOTOREN ANSCHLUSS)

REMOTE

X-1(x): X13(n°1)-HAN50D
X-2(x): X13(n°2)-HAN50D

Title			
CONTROLLER 12 MOTOREN with REMOTE			
(version B with speed) STEUERUNG SCHALTPLAN			
Size	Number	Revision	
A3	FL12PRM-2LV	Plan n°02_343	
Version C			
Date:	12-Dec-2002	Sheet 2 of	2
File:	D:\ARCHIV02\03\12LV_C.SCH	Drawn By:	VS

NETZ ANSCHLUSS
3x400V+N+PE/32A

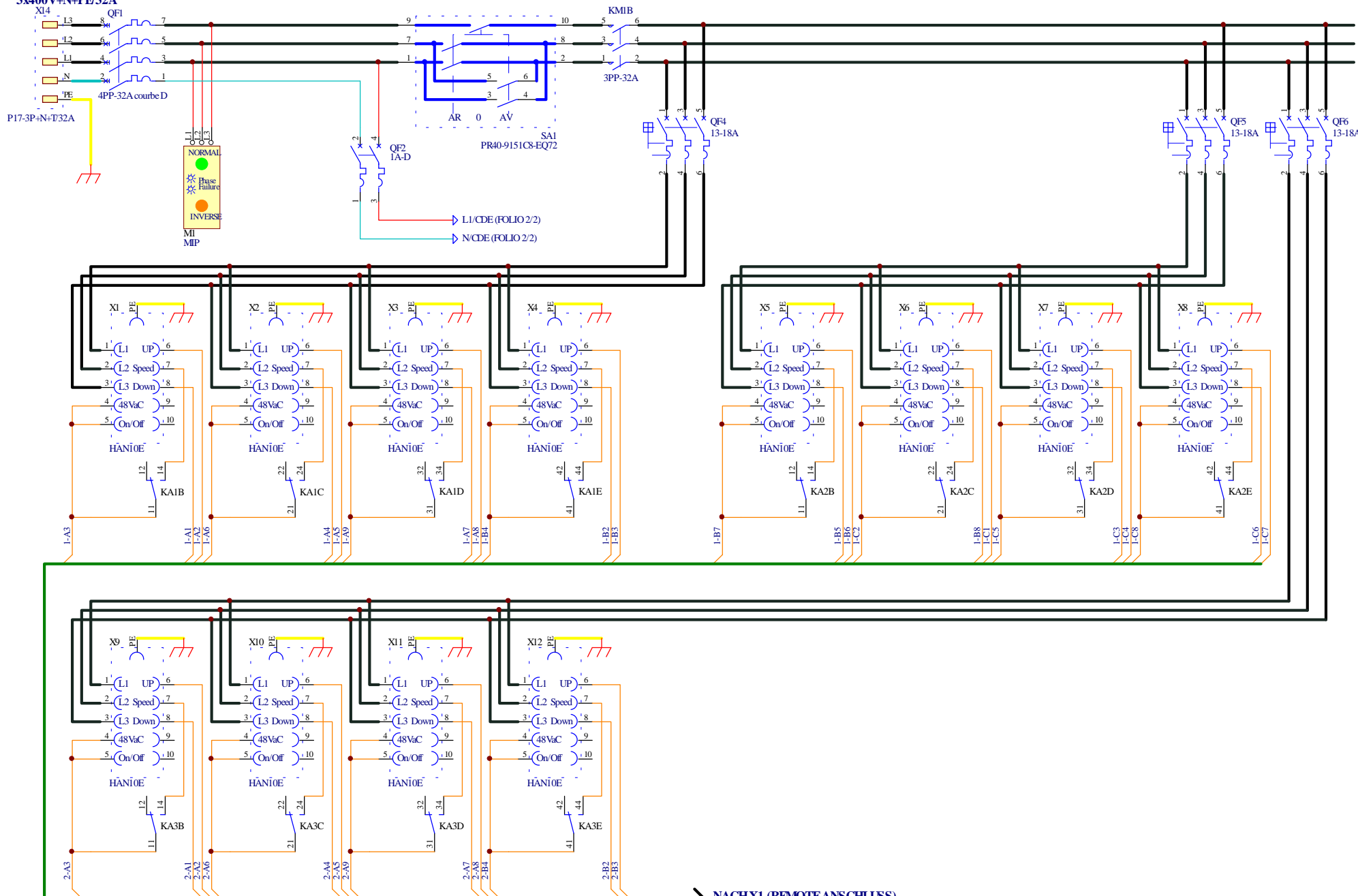

→ **NACHXI (REMOTEANSCHLUSS)**
(FOLIO 2/2)

Title		CONTROLLER 12 MOTOREN with REMOTE (version B with 2 speed) KRAFTSCHALTPLAN	
Size	Number	FLI2PRM-2LV	Revision Plan n°02_396 remplace n°02_342
A3			
Date:	12-Dec-2002	Sheet 1 of	2
File:	D:\ARCHIV\02\03_2LV_PSCH	Drawn By:	VS

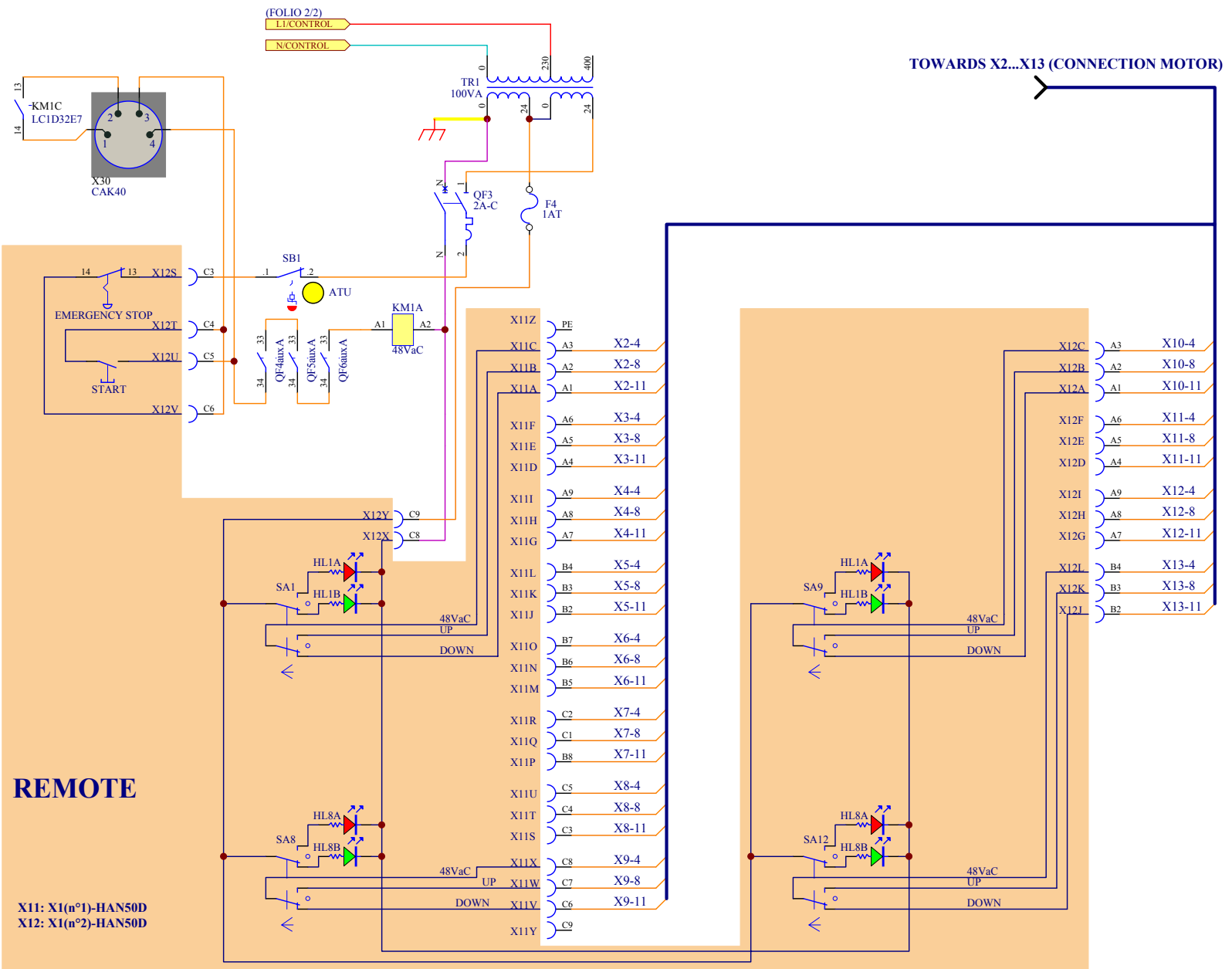

Title			
12 CHANNEL CONTROLLER 19" WITH REMOTE FOR HOISTS WITH INTERNALS CONTACTORS (POWER CIRCUIT)			
Size	Number	Revision	
A3	FL12PRM-LV	Plan n°03_160	
Date:	3-Apr-2003	Sheet 2 of 2	
File:	D:\APPL\FL12PR-1\12PRMLVC.SCH	Drawn By: VS	

POWER SUPPLY
3x400V+N+PE/32A

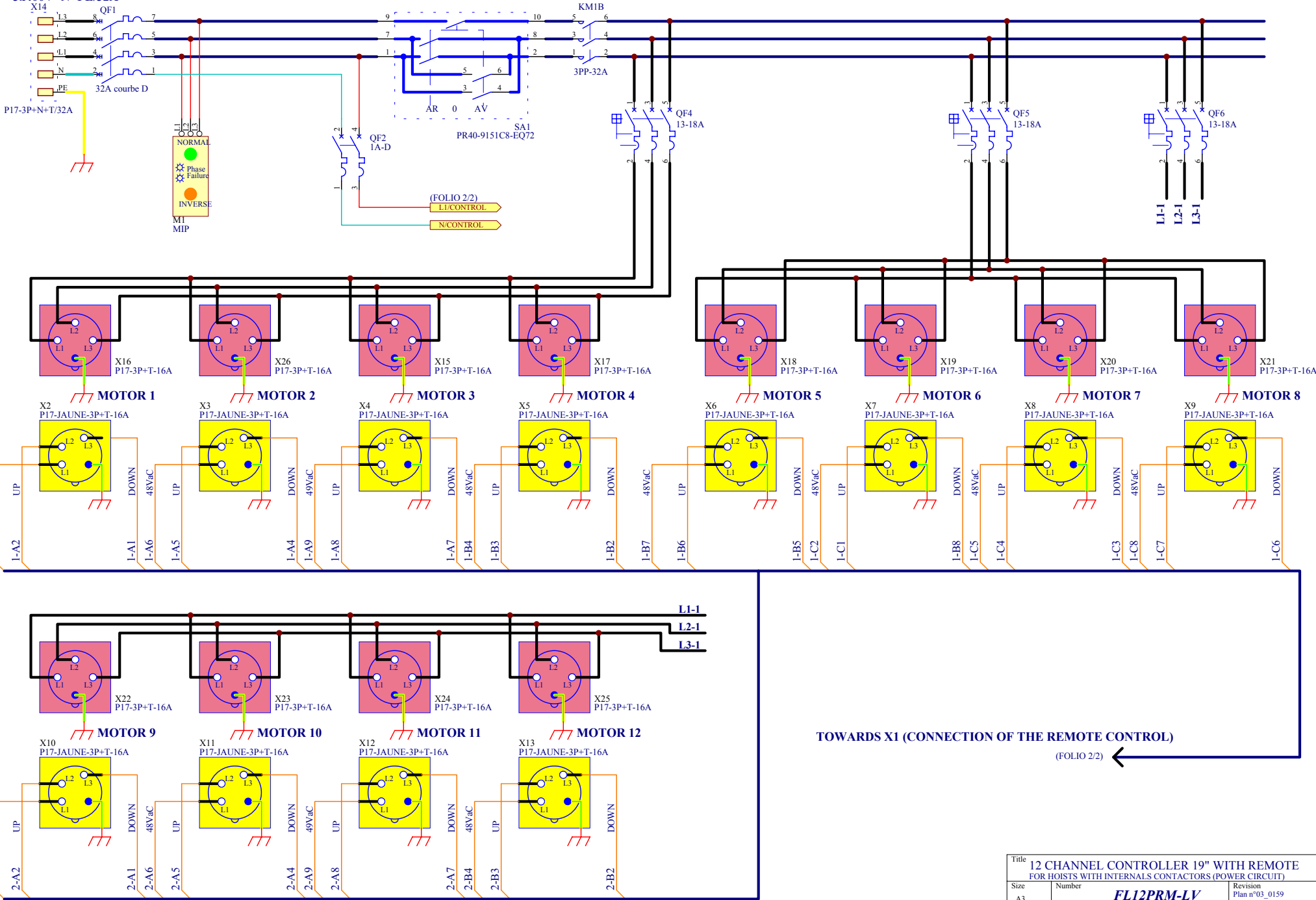

TOWARDS X1 (CONNECTION OF THE REMOTE CONTROL)
(FOLIO 2/2) ←

Title		12 CHANNEL CONTROLLER 19" WITH REMOTE FOR HOISTS WITH INTERNALS CONTACTORS (POWER CIRCUIT)	
Size	Number	Revision	
A3	FL12PRM-LV	Plan n°03_0159	replace n°02_056
Date:	3-Apr-2003	Sheet 1 of 2	
File:	D:\APPL\FL12PR-1\12PRMLVP SCH	Drawn By:	VS

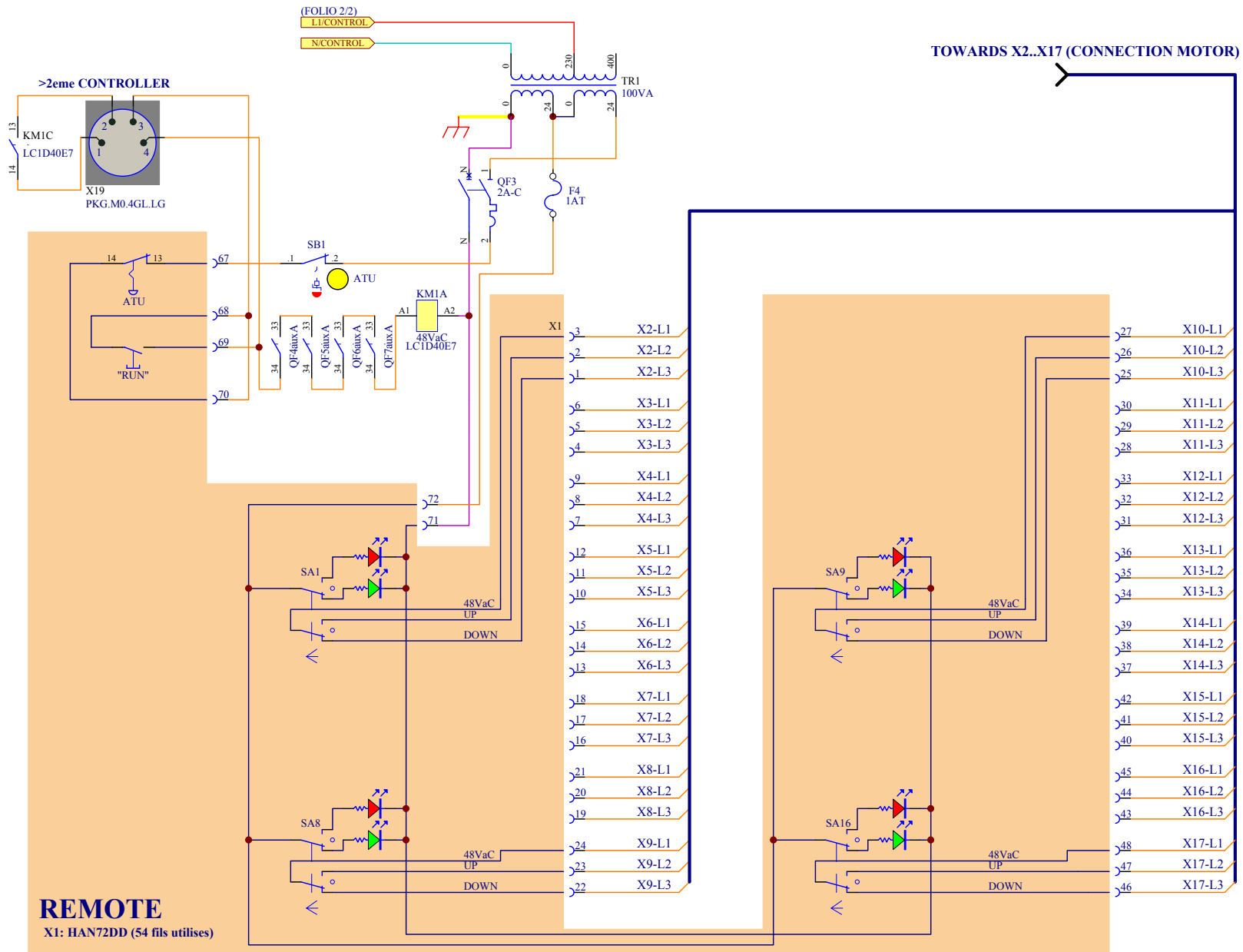

TOWARDS X2..X17 (CONNECTION MOTOR)

REMOTE
X1: HAN72DD (54 files utilises)

Title		CONTROLLER 16 MOTOREN with REMOTE (eigenes 48V Schutze) STEUERUNG SCHALTPLAN	
Size	Number	Revision	Plan n°02_274
A3	FL16PRM-LV		
Date:	3-Apr-2003	Sheet 2 of 2	
File:	D:\APPL1\FL16PR-1\16PRMLVC.SCH	Drawn By:	VS

POWER SUPPLY
3x400V+N+PE/40A

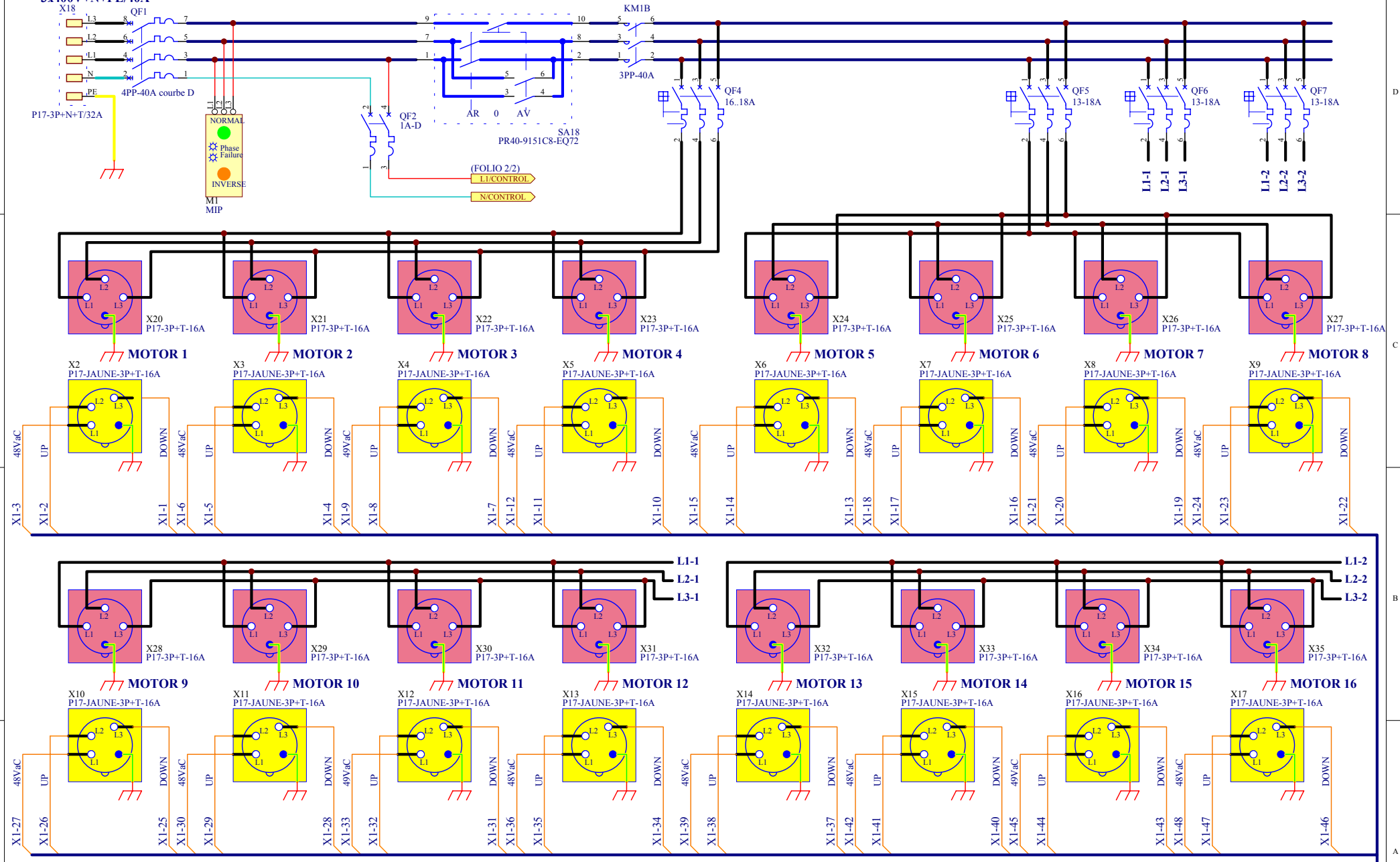

TOWARS X1 (CONNECTION OF THE REMOTE CONTROL)

(FOLIO 2/2)

Title		16 CHANNEL CONTROLLER 19" WITH REMOTE FOR HOISTS WITH INTERNALS CONTACTORS (POWER CIRCUIT)	
Size	Number	Revision	
A3		Plan n°03_164	
Date:	3-Apr-2003	Sheet 1 of 2	
File:	D:\APPLI\FI16PR-1\16PRMLVP.SCH	Drawn By: VS	

FL16PRM-LV

replace n°02_273

NETZANSCHLUSS
3x400V+N+PE/16A

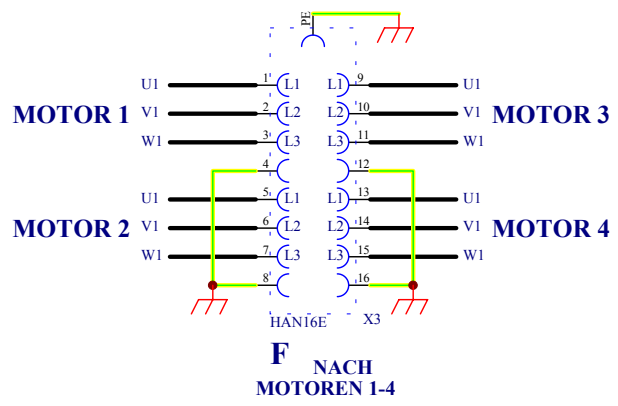
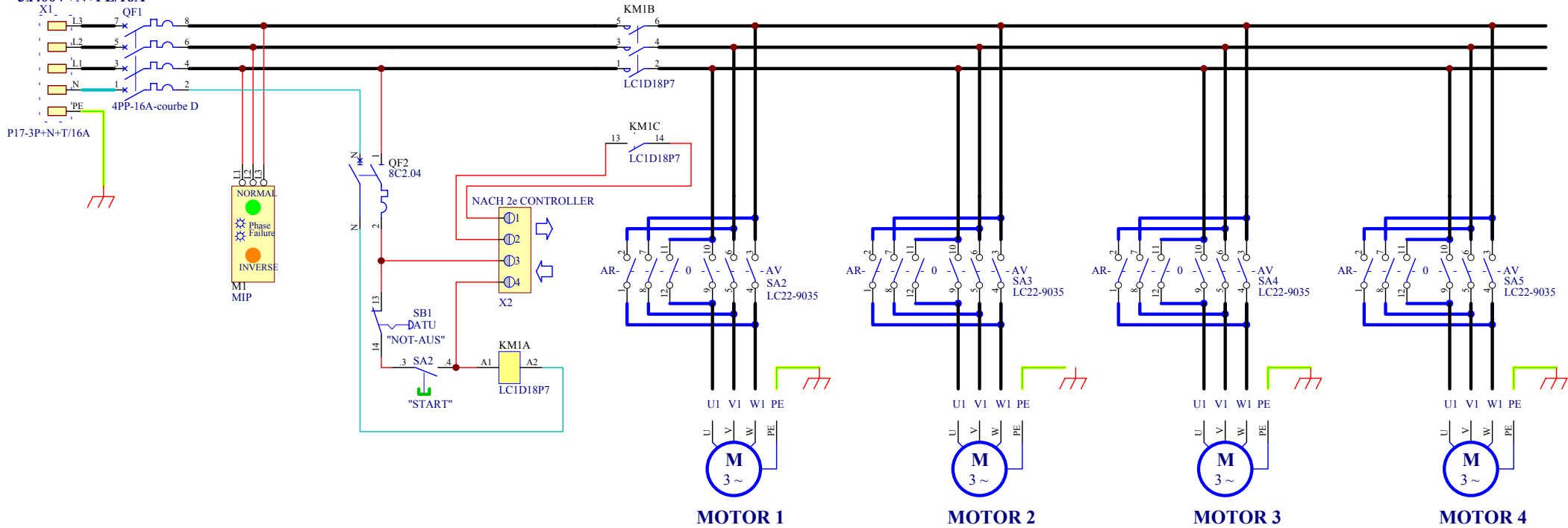

Title 4 CHANNEL CONTROLLER 19" WITHOUT REMOTE		
Size A3	Number R4P	Revision Plan n°03_081 remplace n°00_091
Date: 11-Mar-2003	Sheet 1 of 1	Drawn By: VS
File: D:\APPL\IR4P\R4P_2.SCH		

NETZ ANSCHLUSS
3x400V+N+PE/32A

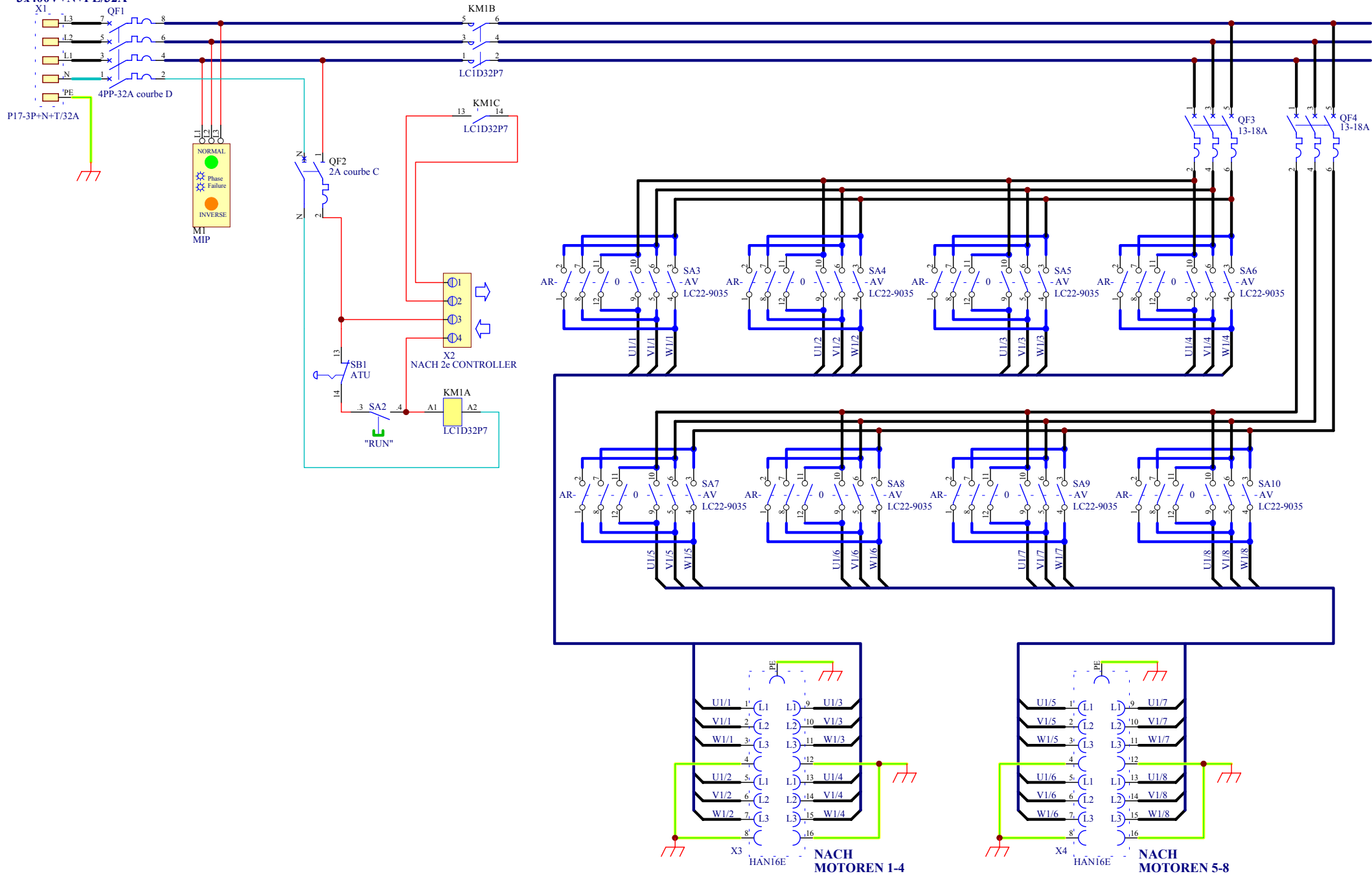

Title 8 CHANNEL CONTROLLER 19" WITHOUT REMOTE		
Size A3	Number R8P	Revision Plan n°03_084 remplace n°00_092
Date: 11-Mar-2003	Sheet 1 of 1	Drawn By: VS
File: D:\APPL\R8P\R8P_2.SCH		

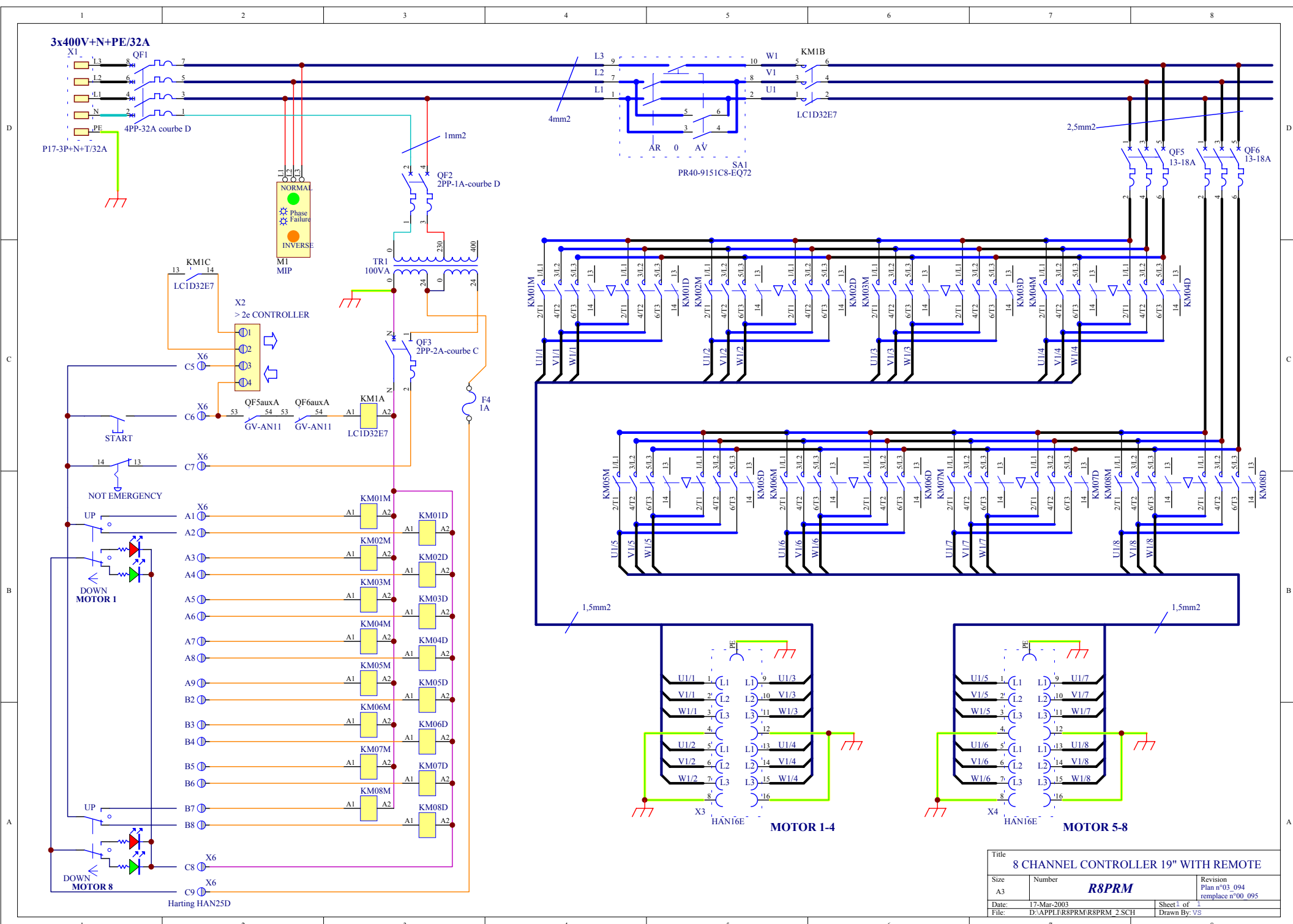

3x400V+N+PE/32A

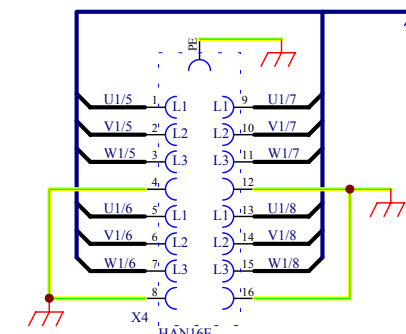
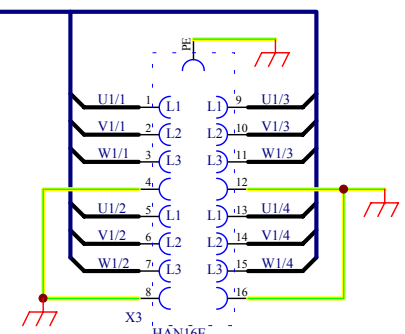
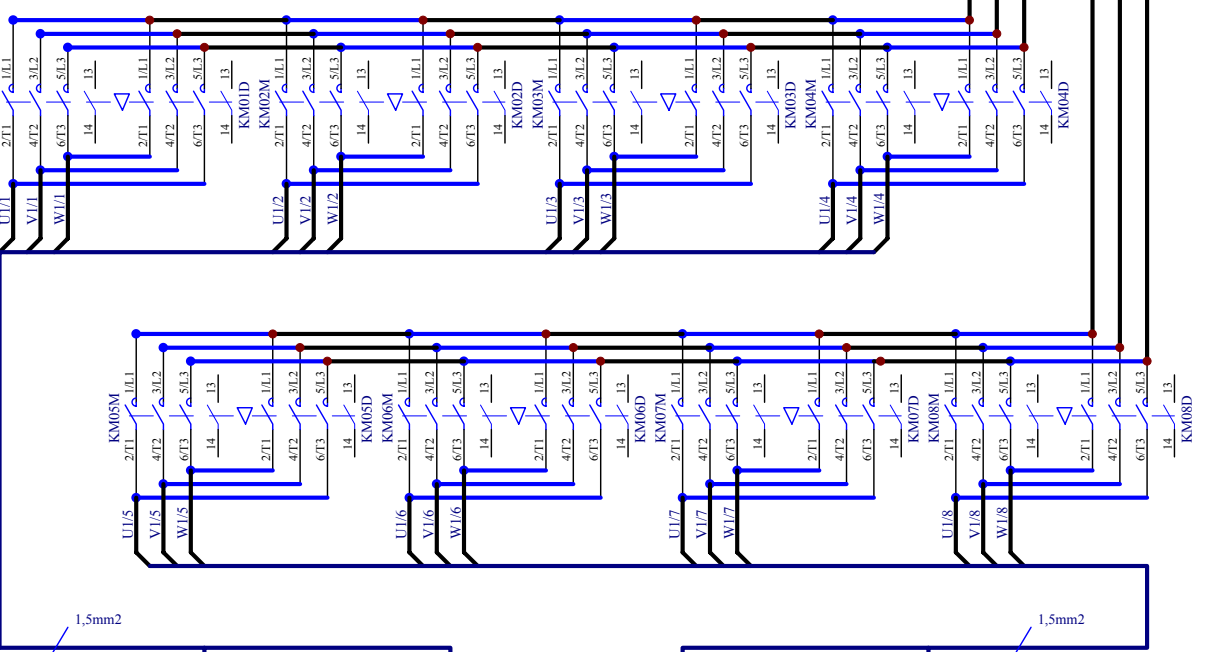
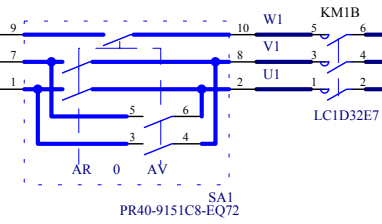
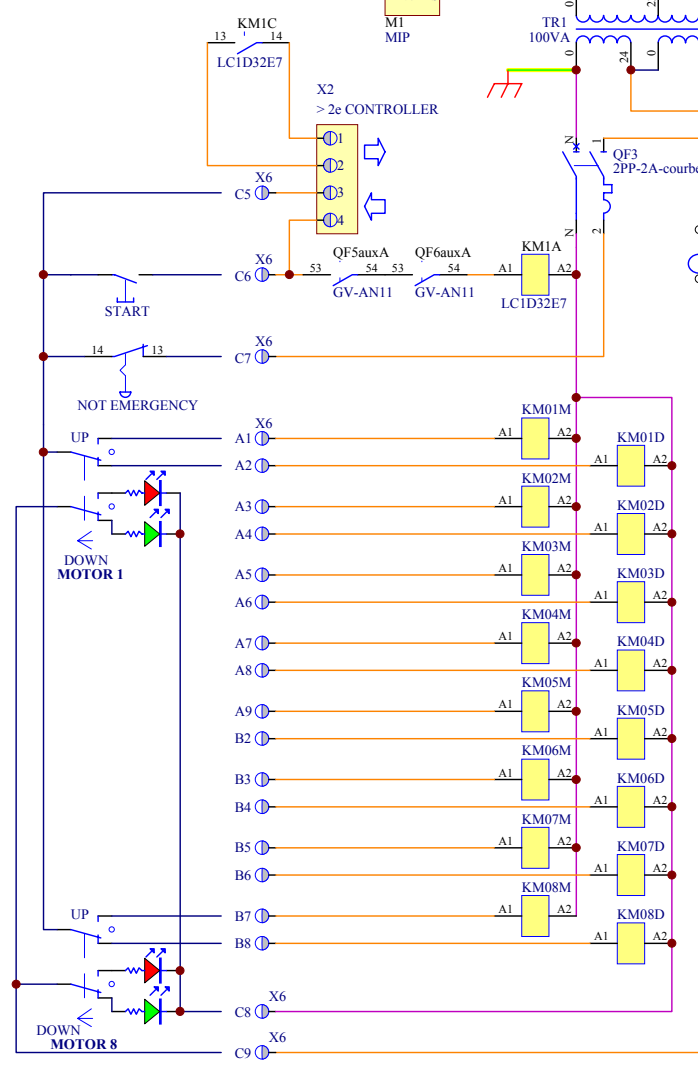
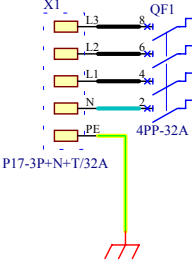

Title		
8 CHANNEL CONTROLLER 19" WITH REMOTE		
Size	Number	Revision
A3	R8PRM	Plan n°03_094
Date:	17-Mar-2003	Sheet 1 of 1
File:	D:\APPL\IR8PRM\IR8PRM_2.SCH	Drawn By: VS

NETZ ANSCHLUSS

3x400V+N+PE/32A

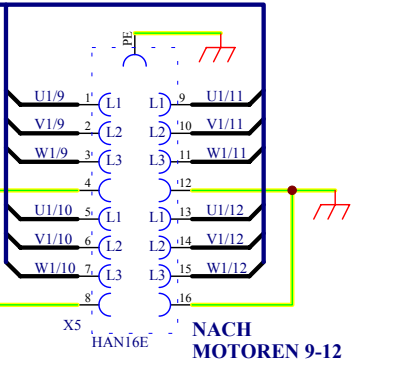
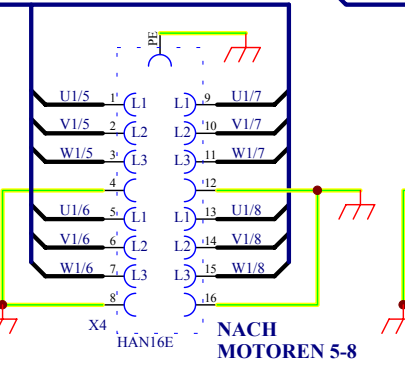
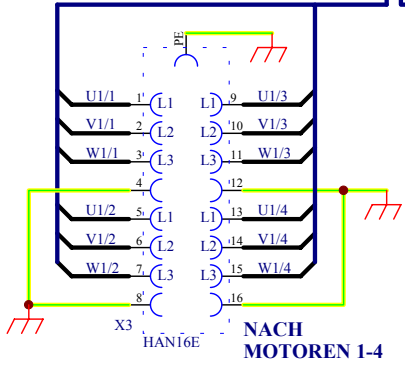
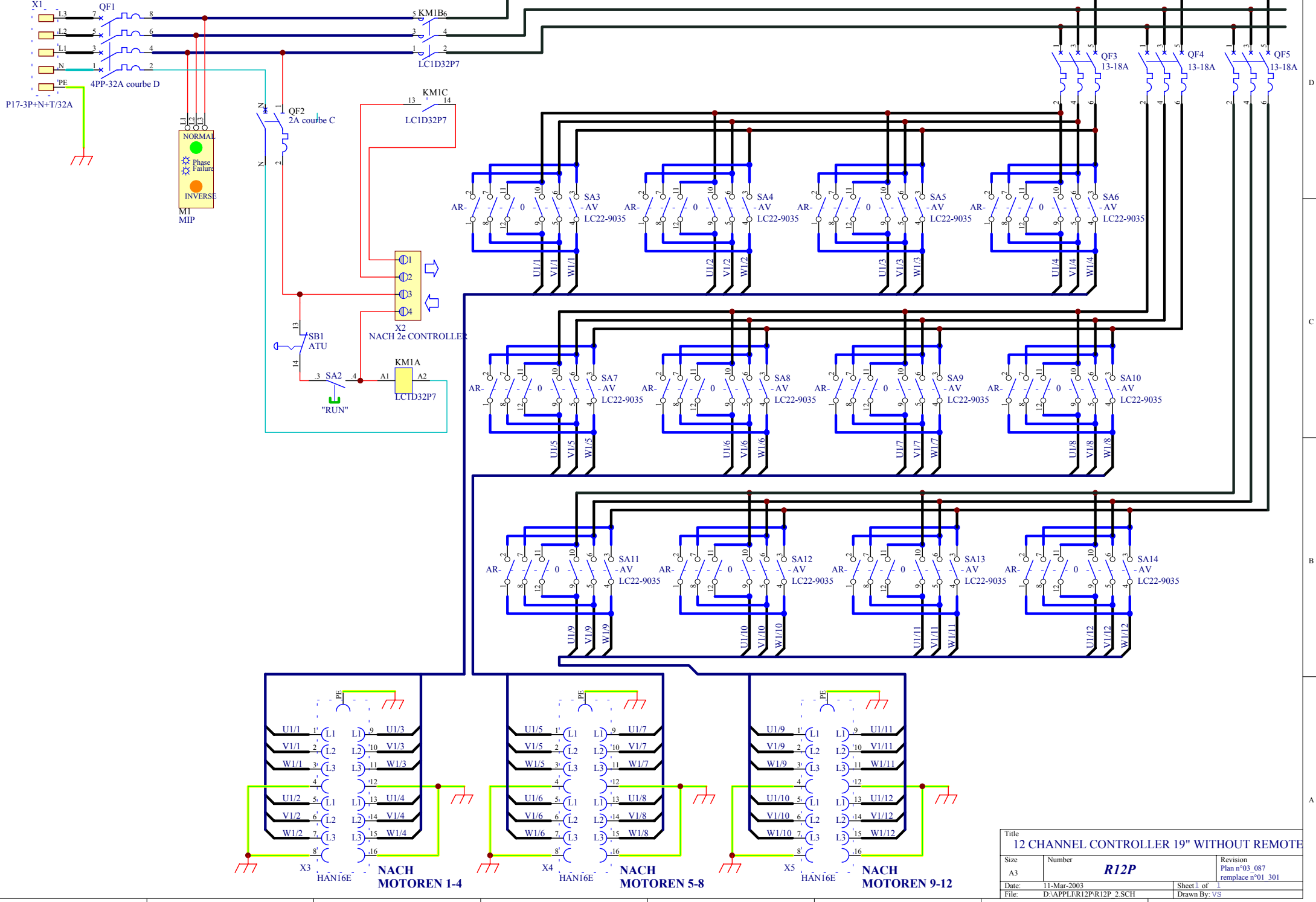

Title		
12 CHANNEL CONTROLLER 19" WITHOUT REMOTE		
Size	Number	Revision
A3	R12P	Plan n°03_087 remplace n°01_301
Date:	11-Mar-2003	Sheet 1 of 1
File:	D:\APPL\RI2P\RI2P_2.SCH	Drawn By: VS

3x400V+N+PE/32A

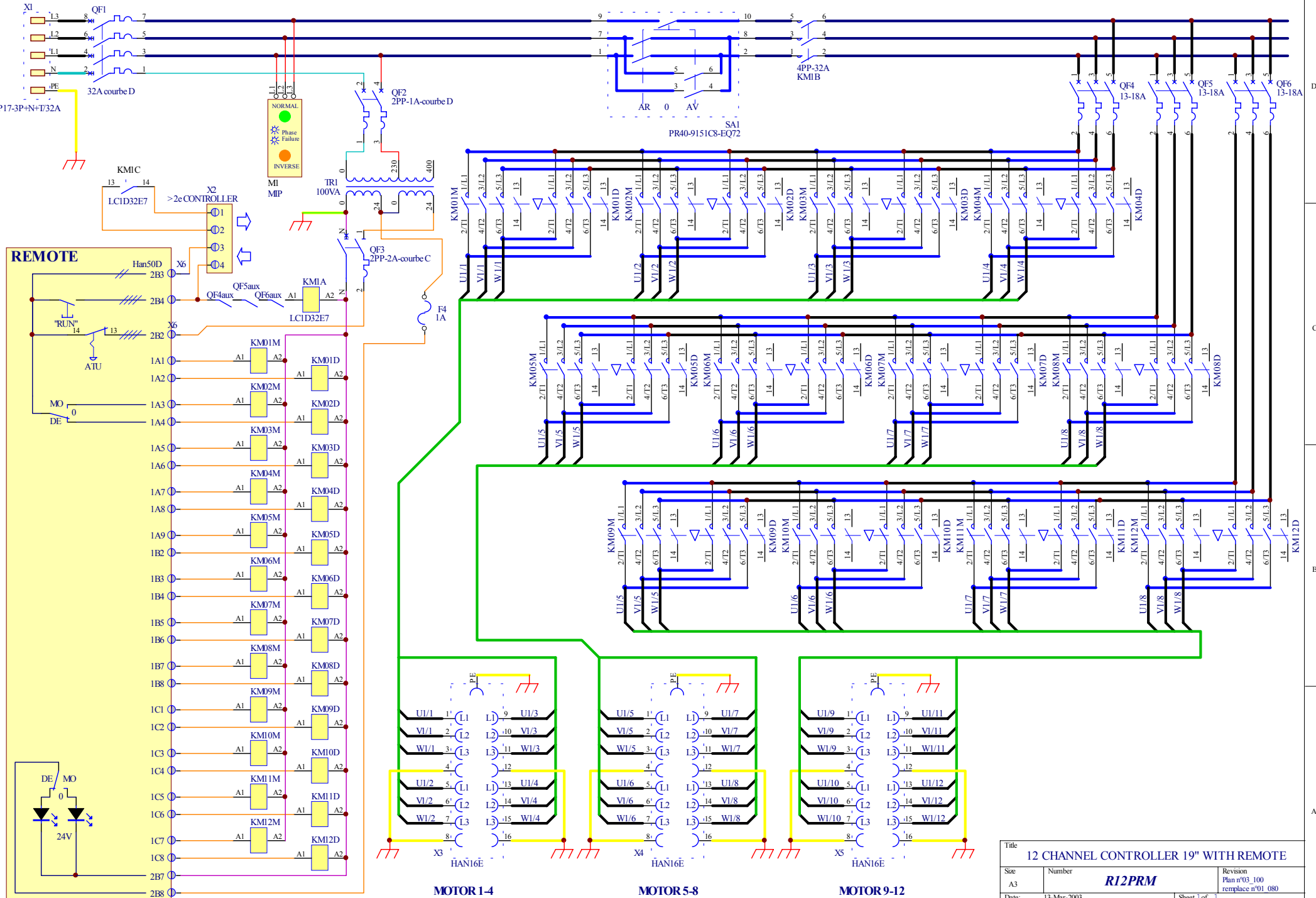

Title			12 CHANNEL CONTROLLER 19" WITH REMOTE		
Size	Number		Revision		Plan n°03_100
A3	R12PRM		replaces n°01_080		
Date:	13-Mar-2003	Sheet 1 of 1	Drawn By: VS		
File:	D:\APPL\U12PRM\R12PRM_2.SCH				

NETZ ANSCHLUSS
3x400V+N+PE/32A

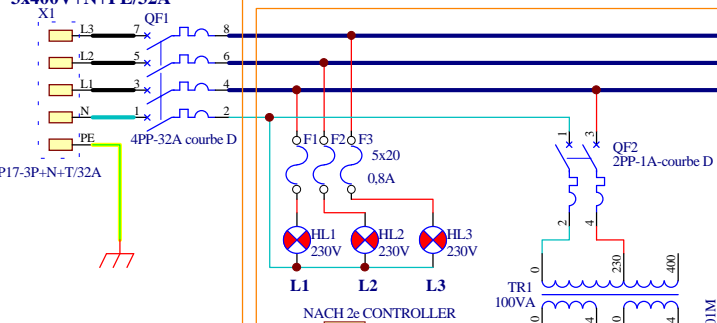

REMOTE

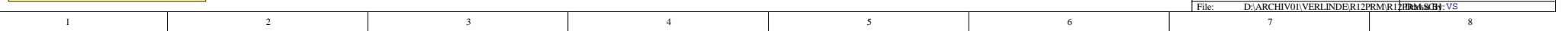
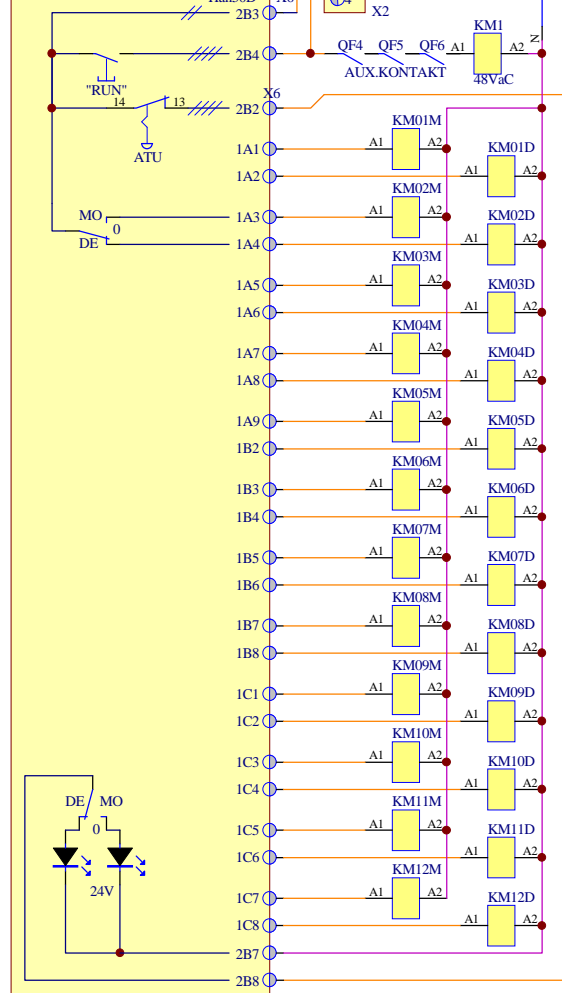

NACH MOTOREN 1-4

NACH MOTOREN 5-8

NACH MOTOREN 9-12

Title		12 CHANNEL CONTROLLER 19" WITH REMOTE	
Size	Number	R12PRM	
A3		Revision Plan n°01_080	
Date:	4-Feb-2003	Sheet	1of 2
File:	D:\ARCHIV01\VERLINDER\R12PRM\R12PRM\SCH\VS		

NETZ ANSCHLUSS
3x400V+N+PE/32A

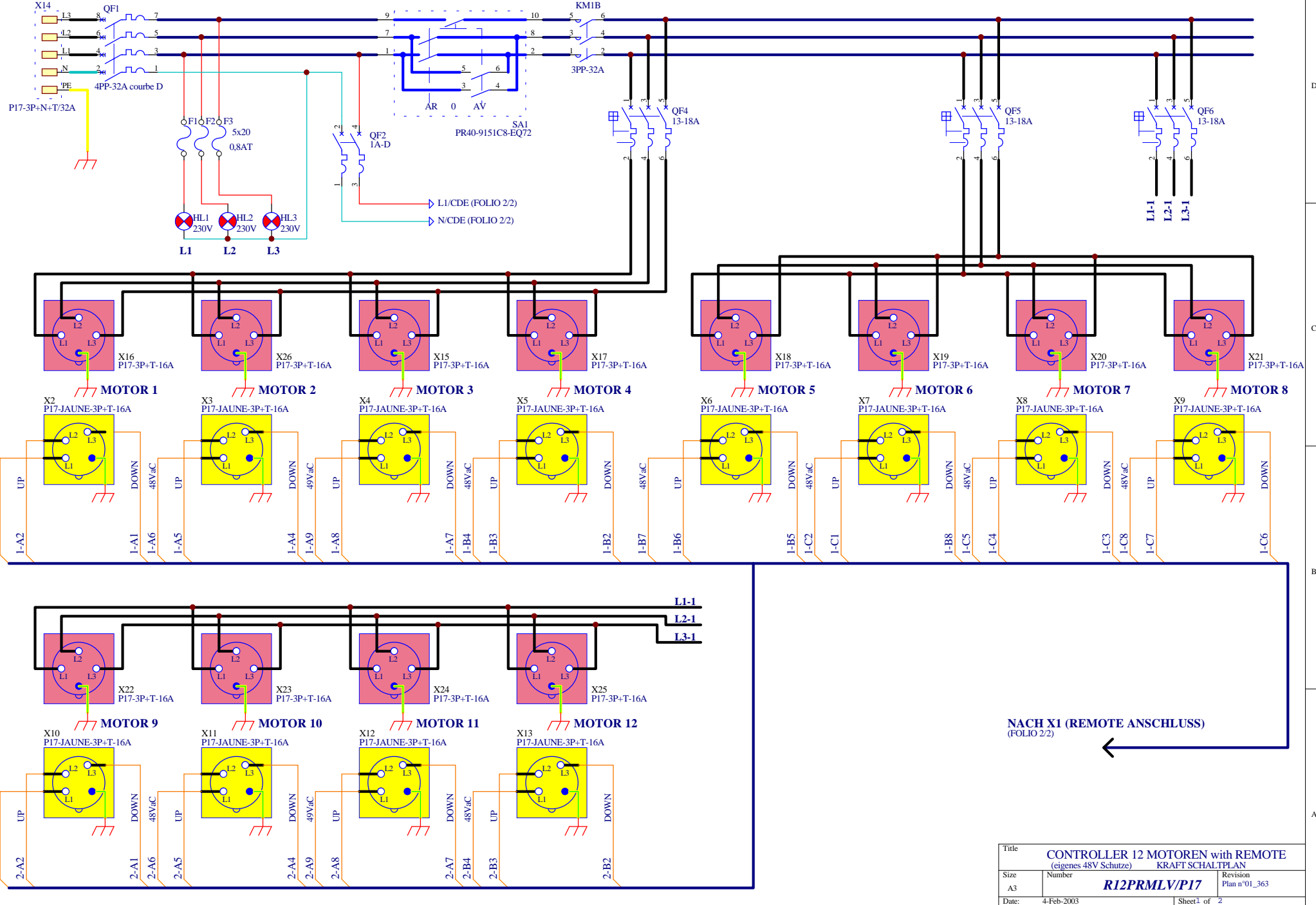

NACH X1 (REMOTE ANSCHLUSS)
(FOLIO 2/2)

Title		CONTROLLER 12 MOTOREN with REMOTE (eigenes 48V Schutze) KRAFTSCHALTPLAN	
Size	Number	R12PRMLV/P17	Revision Plan n°01_363
Date:	4-Feb-2003	Sheet 1 of 2	
File:	D:\ARCHIV01\...R12PLV_P.SCH	Drawn By: VS	

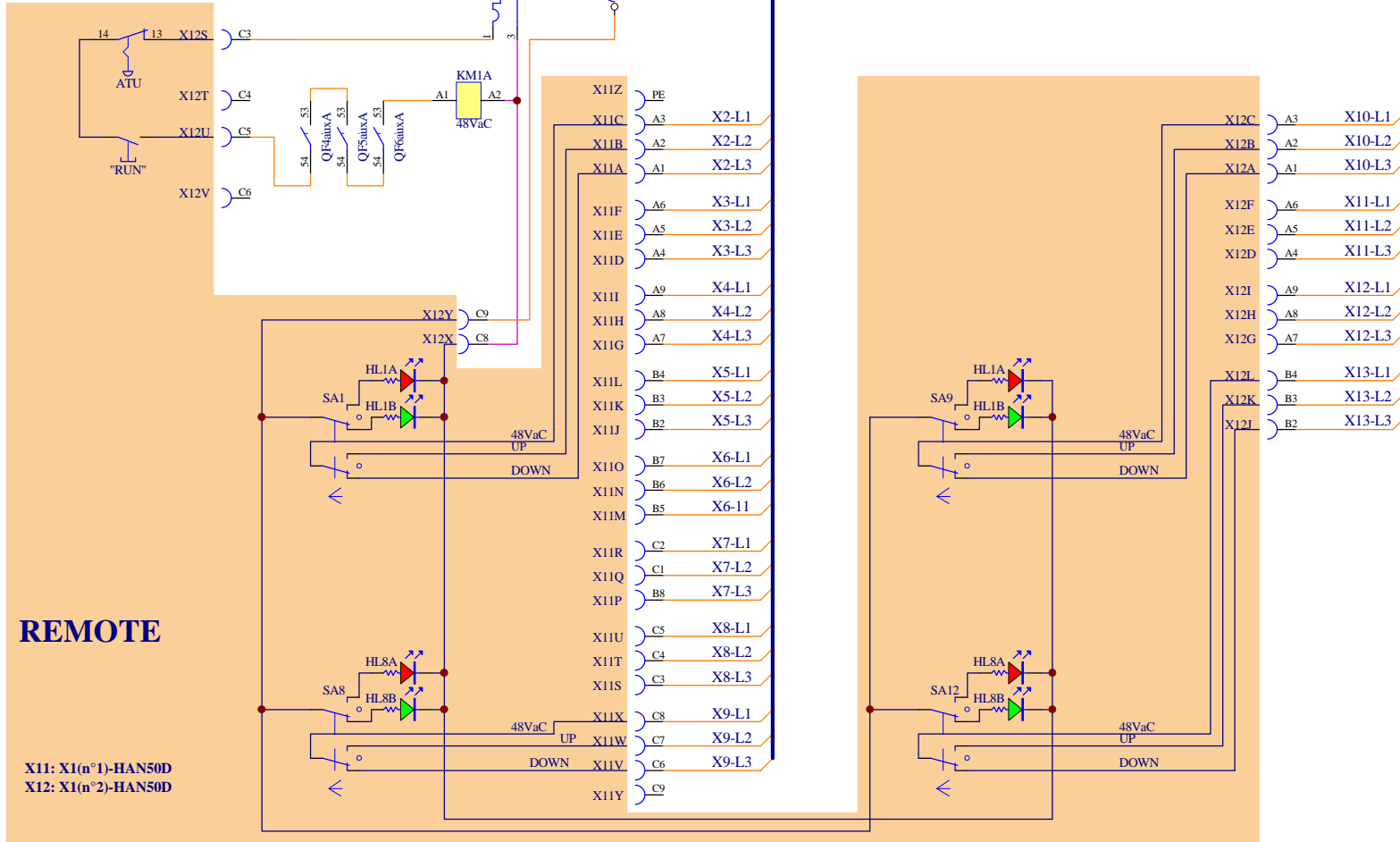

REMOTE

X11: X1(n°1)-HAN50D
X12: X1(n°2)-HAN50D

NACH X2 bis X13 (MOTOREN ANSCHLUSS)

Title		CONTROLLER 12 MOTOREN with REMOTE (eigenes 48V Schutze) STEUERUNG SCHALTPLAN	
Size	Number	Revision	Plan n°01_364
A3	R12PRMLV/P17		
Date:	4-Feb-2003	Sheet 2 of 2	
File:	D:\ARCHIV01\...R12PLV_C.SCH	Drawn By:	VS

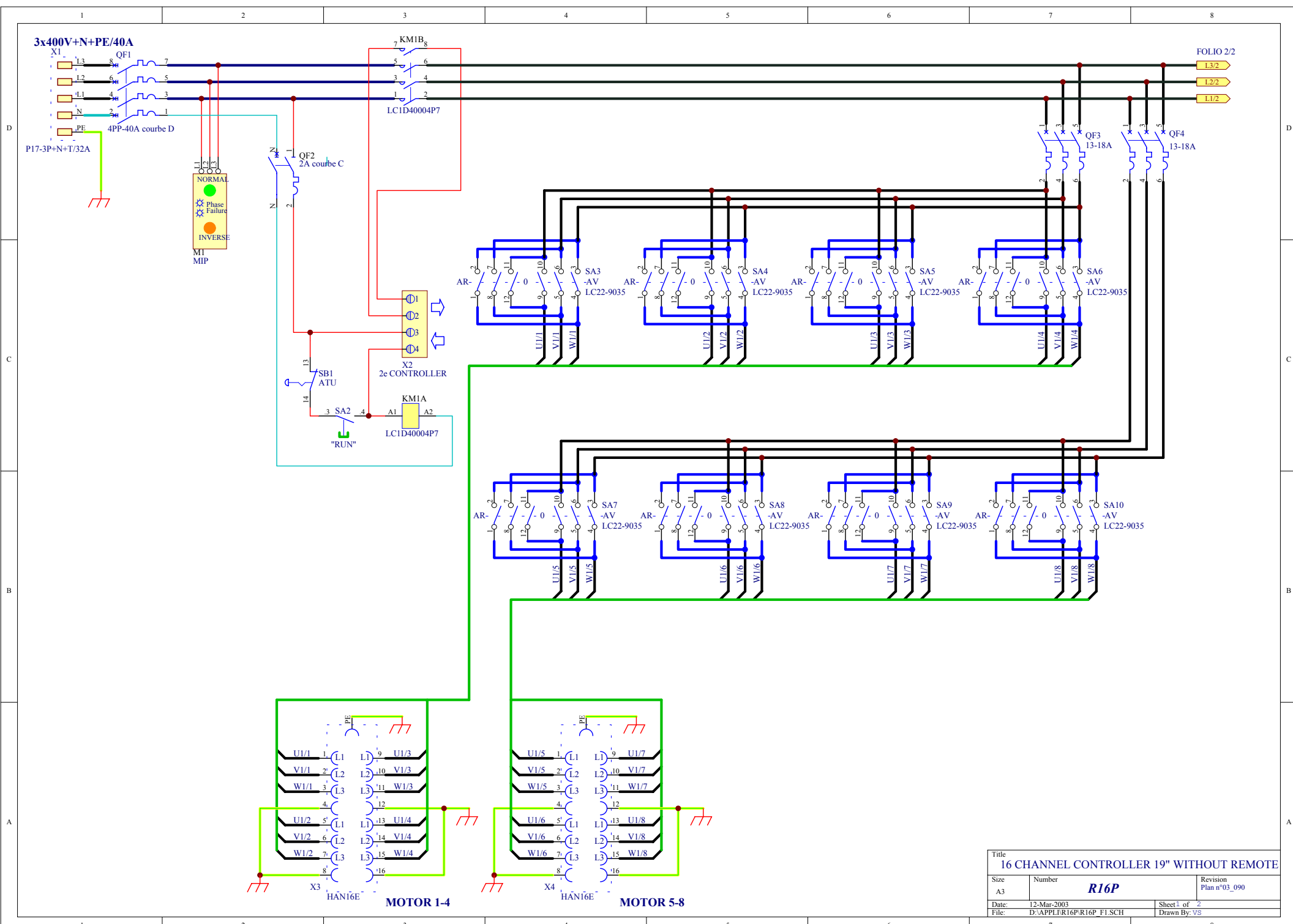

Title		
16 CHANNEL CONTROLLER 19" WITHOUT REMOTE		
Size	Number	Revision
A3	R16P	Plan n°03_090
Date:	12-Mar-2003	Sheet 1 of 2
File:	D:\APPLI\R16P\R16P_FL.SCH	Drawn By: VS

FOLIO 1/2

L3/2
L2/2
L1/2

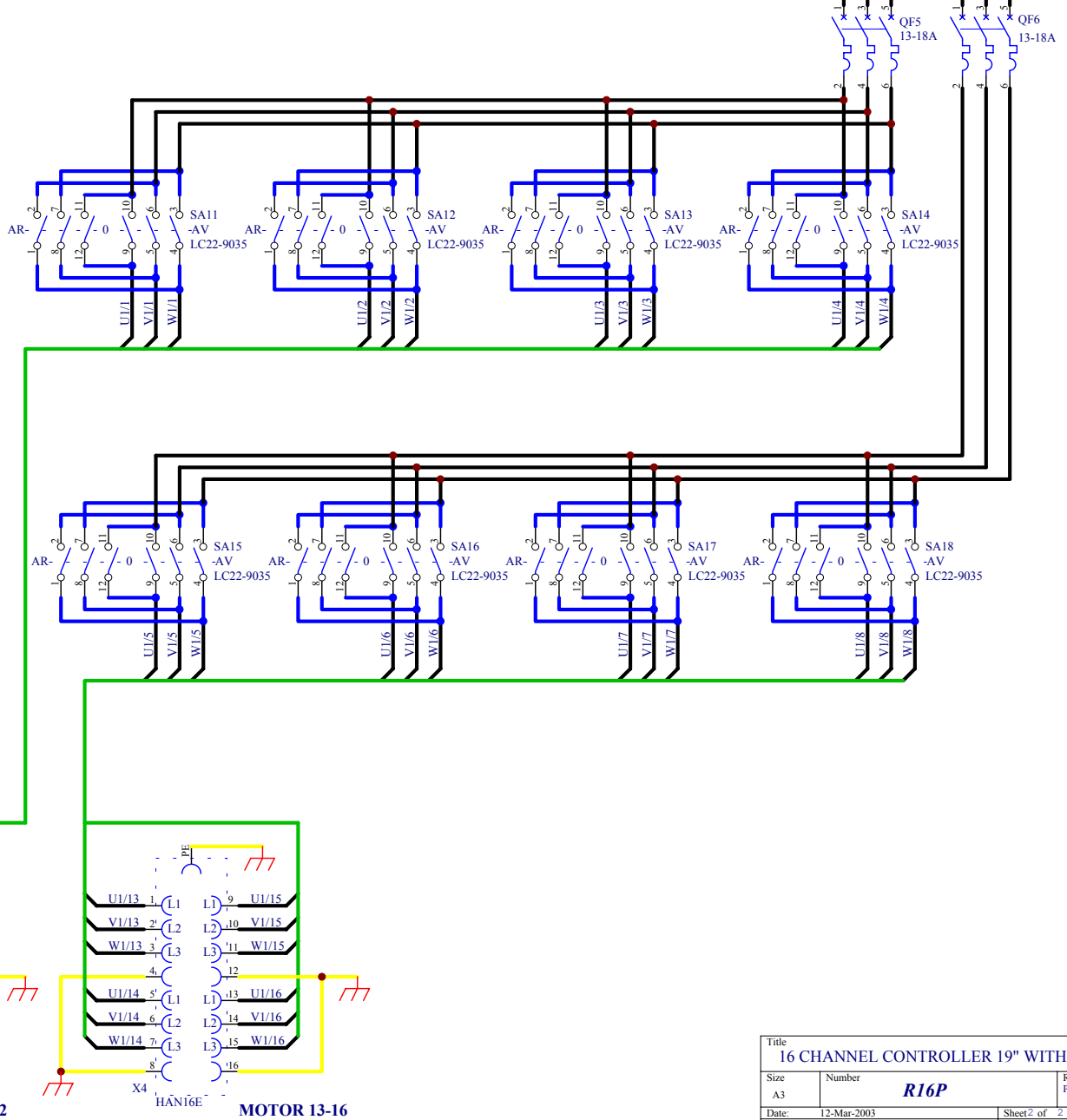

Title 16 CHANNEL CONTROLLER 19" WITHOUT REMOTE		
Size A3	Number R16P	Revision Plan n°03_091
Date: 12-Mar-2003	Sheet 2 of 2	
File: D:\APPL\IR16P\IR16P_F2.SCH	Drawn By: VS	

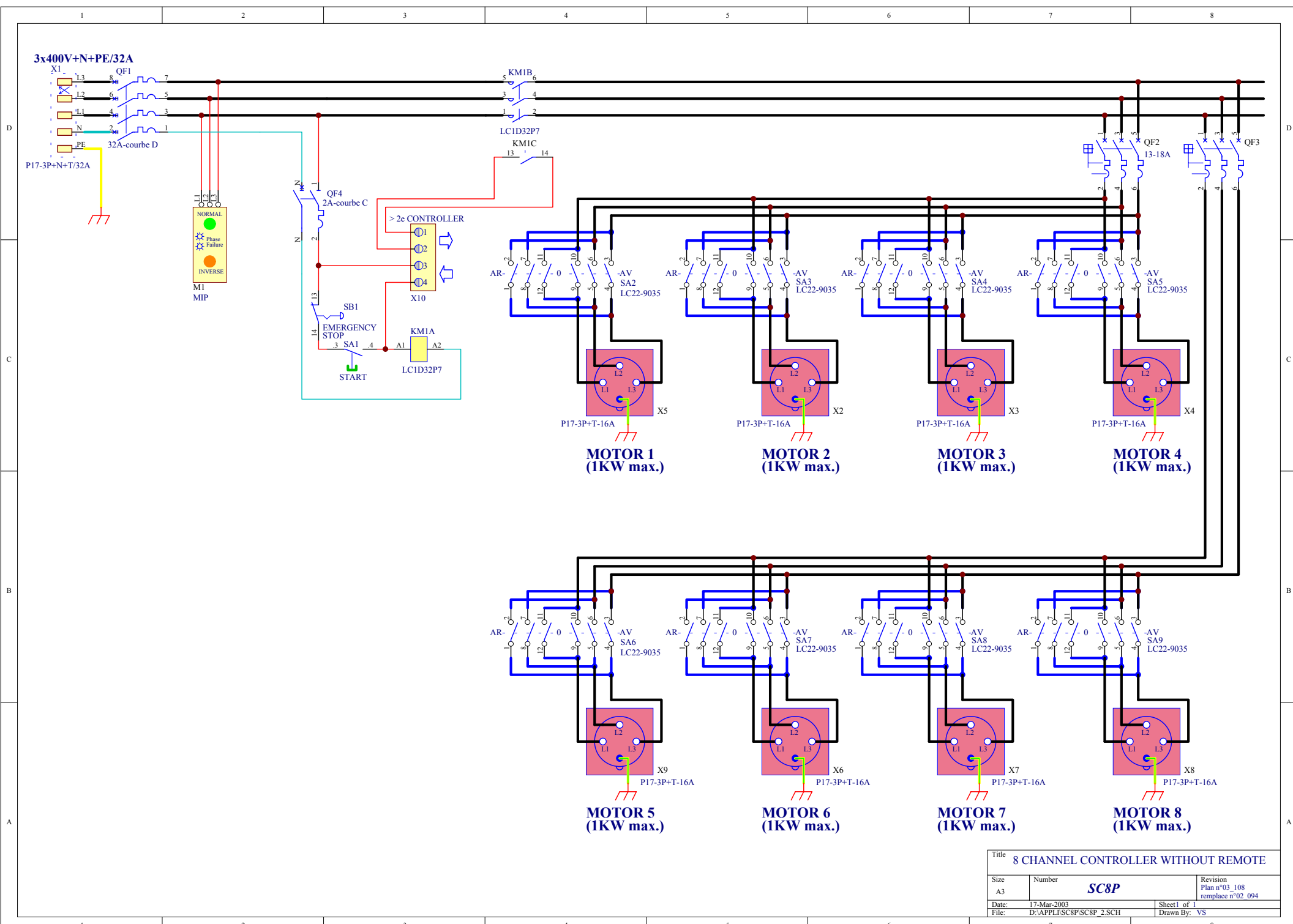

Title			8 CHANNEL CONTROLLER WITHOUT REMOTE
Size	Number	SC8P	
A3		Revision Plan n°03_108 remplace n°02_094	
Date:	17-Mar-2003	Sheet1 of 1	
File:	D:\APPLI\SC8P\SC8P_2.SCH	Drawn By: VS	

NETZANSCHLUSS
3x410V+PE/16A

Embase BALS 2831
4P/16A

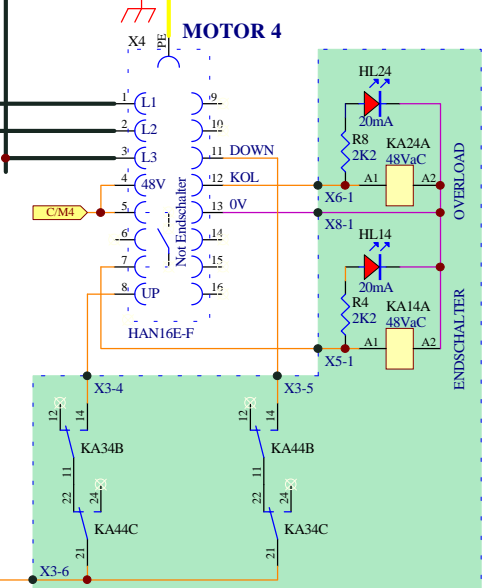
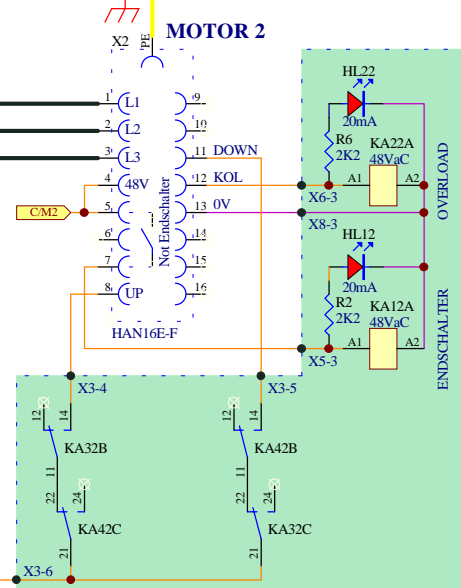
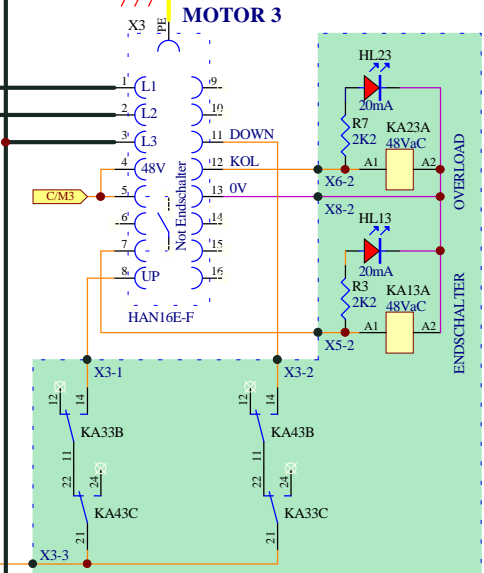
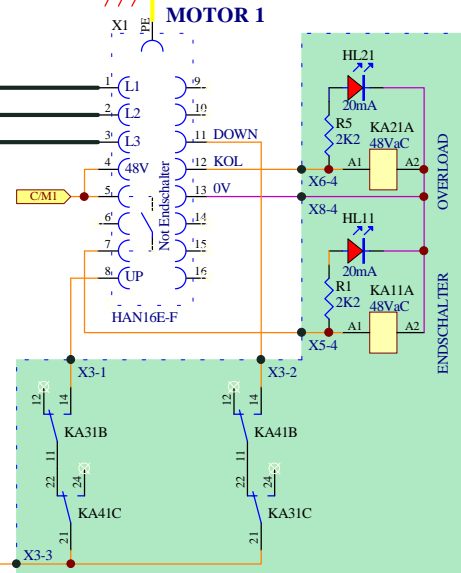
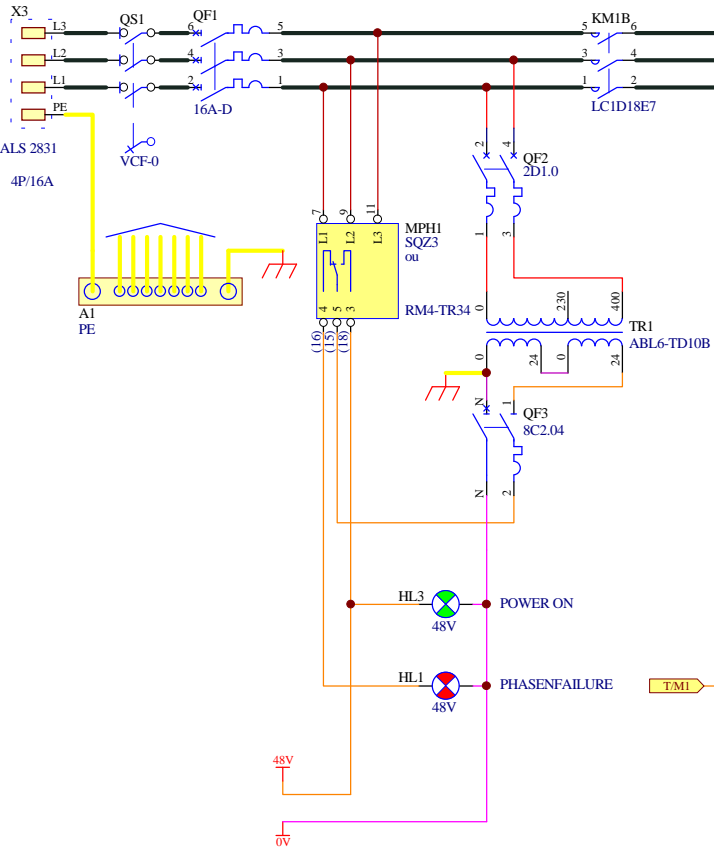

Title		
CONTROLLER 4 MOTOREN (POWER CIRCUIT)		
Size	Number	Revision
A3	B4PRMLV-C1	Plan n°03_056
Date:	14-Feb-2003	Sheet 1 of 1
File:	D:\APPL1\B4PRML-1\B4LV_P.SCH	Drawn By: VS