

# STAGEMAKER



---

## OWNER'S MANUAL

---

CHAIN HOIST SL10 1004 M2 A D8+

DOC449228A / X270381en-US / A / 03 Aug 2020 / X192723/A  
02910850290010 Order 38/2020

 **VERLINDE**<sup>™</sup>  
LIFTING EQUIPMENT

Original instructions



## TABLE OF CONTENTS

<b>1</b>	<b>INTRODUCTION.....</b>	<b>7</b>
<b>1.1</b>	<b>About these instructions.....</b>	<b>7</b>
1.1.1	Use of the instructions.....	7
1.1.2	Copyright notice.....	7
1.1.3	Definition of terms.....	7
1.1.4	Symbols used in the instructions.....	8
1.1.5	Available technical documents.....	9
<b>1.2</b>	<b>About this product.....</b>	<b>9</b>
1.2.1	Use of the product.....	9
1.2.2	Terms of warranty.....	10
1.2.3	Identification of the product.....	11
1.2.4	Standards and directives.....	12
<b>1.3</b>	<b>Contact information.....</b>	<b>12</b>
<b>2</b>	<b>HEALTH, SAFETY AND THE ENVIRONMENT (HSE).....</b>	<b>14</b>
<b>2.1</b>	<b>Safety messages and signals.....</b>	<b>14</b>
2.1.1	Signal words.....	14
2.1.2	Hazard symbols.....	14
2.1.3	Mandatory action symbols.....	16
2.1.4	Prohibited action symbols.....	16
2.1.5	Product safety labels.....	16
<b>2.2</b>	<b>Responsibilities of the owner.....</b>	<b>17</b>
2.2.1	Preventing work-related hazards.....	17
2.2.2	Personal protective equipment.....	17
2.2.3	Incident reporting.....	19
<b>2.3</b>	<b>Conditions for product use.....</b>	<b>19</b>
2.3.1	Operating conditions.....	19
2.3.2	Prohibited use.....	19
2.3.3	Changes to the product.....	20
<b>2.4</b>	<b>Safety devices.....</b>	<b>21</b>
2.4.1	Hoist.....	21
<b>2.5</b>	<b>Protective measures.....</b>	<b>21</b>
2.5.1	Emergency stopping.....	21
2.5.2	Main isolation switch.....	22
2.5.3	Lockout-tagout-tryout procedure.....	23
2.5.4	Fire safety.....	24
<b>2.6</b>	<b>Emissions.....</b>	<b>24</b>
2.6.1	Noise.....	24
<b>2.7</b>	<b>Personnel requirements.....</b>	<b>25</b>
<b>2.8</b>	<b>Environmental information.....</b>	<b>25</b>
2.8.1	Product life cycle stages.....	25
2.8.2	Handling waste material.....	26
<b>3</b>	<b>PRODUCT DESCRIPTION.....</b>	<b>28</b>
<b>3.1</b>	<b>Technical data.....</b>	<b>28</b>
3.1.1	Hoist duty class.....	28
<b>3.2</b>	<b>Functional description.....</b>	<b>29</b>
3.2.1	Functional principle of the electrical chain hoist.....	29
3.2.2	Kinematic chain for electrical chain hoist.....	30
<b>3.3</b>	<b>Chain hoist.....</b>	<b>31</b>

3.3.1	Key parts of the chain hoist.....	31
3.3.2	Chain drive.....	31
<b>3.4</b>	<b>Controller.....</b>	<b>32</b>
3.4.1	Pendant controller.....	32
<b>3.5</b>	<b>Options.....</b>	<b>32</b>
3.5.1	Manual brake release.....	32
3.5.2	Rotating geared limit switch.....	33
<b>4</b>	<b>INSTALLATION.....</b>	<b>37</b>
<b>4.1</b>	<b>General instructions for installation.....</b>	<b>37</b>
<b>4.2</b>	<b>Safety during installation.....</b>	<b>37</b>
<b>4.3</b>	<b>Installation preparations.....</b>	<b>38</b>
4.3.1	Transport, packing, scope of delivery.....	38
4.3.2	Tightening torques for the chain hoist .....	38
4.3.3	Handling the product.....	38
<b>4.4</b>	<b>Fitting the chain bucket.....</b>	<b>39</b>
<b>4.5</b>	<b>Removing and installing the hoist covers.....</b>	<b>40</b>
<b>4.6</b>	<b>Installation steps.....</b>	<b>41</b>
<b>4.7</b>	<b>Suspending the chain hoist.....</b>	<b>41</b>
4.7.1	Supporting structure.....	42
4.7.2	Suspension.....	42
4.7.3	Attaching the hoist to the supporting structure.....	42
<b>4.8</b>	<b>Electrical connections.....</b>	<b>43</b>
4.8.1	Cable gland positions on the hoist.....	43
4.8.2	Connecting the hoist to power supply.....	44
<b>4.9</b>	<b>Adjusting the rotating geared limit switch.....</b>	<b>46</b>
<b>4.10</b>	<b>Adjusting the lower hook position.....</b>	<b>48</b>
<b>5</b>	<b>COMMISSIONING.....</b>	<b>49</b>
<b>5.1</b>	<b>Safety during commissioning.....</b>	<b>49</b>
<b>5.2</b>	<b>Commissioning preparations.....</b>	<b>49</b>
<b>5.3</b>	<b>Commissioning instructions.....</b>	<b>49</b>
5.3.1	Checking the hoist before first run.....	49
5.3.2	Before lifting.....	50
5.3.3	Testing the hoist without load.....	51
5.3.4	Testing the hoist with test load.....	52
<b>5.4</b>	<b>After commissioning.....</b>	<b>53</b>
<b>6</b>	<b>OPERATION.....</b>	<b>54</b>
<b>6.1</b>	<b>Safety during operation.....</b>	<b>54</b>
6.1.1	Operating environment.....	54
6.1.2	Responsibilities of the operator.....	54
<b>6.2</b>	<b>Movements.....</b>	<b>55</b>
6.2.1	Controls for movements.....	55
6.2.2	Motor control methods.....	55
<b>6.3</b>	<b>Checks before operating.....</b>	<b>57</b>
6.3.1	Checking the hoist before every working shift.....	57
6.3.2	Checking the operation with the emergency stop button pressed down.....	58
6.3.3	Checking the operation with the controller enabled.....	58
<b>6.4</b>	<b>Starting the equipment.....</b>	<b>59</b>
6.4.1	Setting up the controller.....	59

<b>6.5</b>	<b>Load handling.....</b>	<b>59</b>
6.5.1	Load handling methods.....	59
6.5.2	Slipping clutch operation.....	70
6.5.3	Hoisting limit switch operation.....	70
<b>6.6</b>	<b>Shutting down the equipment.....</b>	<b>70</b>
<b>7</b>	<b>MAINTENANCE.....</b>	<b>71</b>
<b>7.1</b>	<b>Safety during maintenance.....</b>	<b>71</b>
<b>7.2</b>	<b>Maintenance preparations.....</b>	<b>71</b>
7.2.1	Service personnel.....	72
7.2.2	Preservation of protection class.....	72
<b>7.3</b>	<b>Maintenance schedule.....</b>	<b>72</b>
7.3.1	Design working period (DWP).....	72
7.3.2	General overhaul.....	77
7.3.3	Daily inspections.....	78
7.3.4	Monthly inspections.....	78
7.3.5	Quarterly inspections.....	79
7.3.6	Annual inspections.....	79
7.3.7	Log book.....	80
<b>7.4</b>	<b>Maintaining the hoist.....</b>	<b>81</b>
7.4.1	Checking the suspension.....	81
7.4.2	Checking the brake lining.....	82
7.4.3	Replacing the single brake.....	83
7.4.4	Replacing the single brake.....	86
7.4.5	Replacing the double brake.....	89
7.4.6	Replacing the double brake.....	92
7.4.7	Adjusting the slipping clutch.....	96
7.4.8	Replacing the control voltage fuse.....	98
<b>7.5</b>	<b>Maintaining the chain drive.....</b>	<b>98</b>
7.5.1	Removing the chain bucket.....	98
7.5.2	Inspecting the chain wear.....	99
7.5.3	Lubrication instructions for the chain.....	102
7.5.4	Replacing the chain.....	105
7.5.5	Replacing the chain.....	107
<b>7.6</b>	<b>Maintaining the hook.....</b>	<b>110</b>
7.6.1	Measuring wear on the hook.....	110
7.6.2	Checking the limit switch activator.....	111
<b>7.7</b>	<b>Lubrication.....</b>	<b>112</b>
7.7.1	Safety during lubrication.....	112
7.7.2	General lubrication instructions.....	112
7.7.3	Lubrication points.....	113
7.7.4	Lubricant information.....	113
<b>8</b>	<b>TROUBLESHOOTING.....</b>	<b>115</b>
<b>8.1</b>	<b>Troubleshooting instructions.....</b>	<b>115</b>
<b>9</b>	<b>TRANSPORTATION, STORAGE, AND DISMANTLING.....</b>	<b>117</b>
<b>9.1</b>	<b>Transporting the product.....</b>	<b>117</b>
<b>9.2</b>	<b>Storing the product.....</b>	<b>117</b>
<b>9.3</b>	<b>Dismantling instructions.....</b>	<b>117</b>
9.3.1	Safety during dismantling.....	117
9.3.2	Dismantling the product.....	117



## 1 INTRODUCTION

### 1.1 About these instructions

These instructions offer guidance to enable safe and efficient operation of the product.

Take the time and read these instructions. Knowing the instructions helps you prevent damage to the product, and, most importantly, to the personnel that are situated close to the product. The product is safe when you use it correctly. However, many potential hazards are associated with incorrect operation of the product. The hazards can be avoided when you know how to recognize and anticipate them.

These instructions make you also aware of your responsibilities regarding the use of the product. The instructions help you to ensure that the product is kept in a safe operating condition throughout its lifetime.

These instructions are not intended as a substitute for proper training. The instructions provide recommendations and methods for safe and efficient operation and maintenance of the product. The owner of the product must ensure that all operators are properly trained before they operate the product. It is the responsibility of the owner to always comply with all applicable and prevailing safety and other standards, rules, and regulations.

#### 1.1.1 Use of the instructions

Every person that is exposed to the equipment of the manufacturer must, before operating, servicing, and maintaining such products, read and understand the contents of these instructions and strictly adhere and conform their conduct with and to the information, recommendations, and warnings that are provided in these instructions.

#### NOTE

***Keep these instructions in a safe and accessible location for future reference. The instructions must be accessible by personnel that is operating the equipment or that is exposed to the operating equipment.***



#### **WARNING! IGNORING INSTRUCTIONS HAZARD**

**Failure to follow the given instructions could cause death or serious injury.**



**Read and understand the contents of these instructions before operating, servicing, and maintaining the equipment.**

The manufacturer makes absolutely no warranty whatsoever regarding the contents of these instructions, express or implied, whether arising by operation of law or otherwise, including, but not limited to, any implied warranties of merchantability or fitness for a particular purpose.

#### 1.1.2 Copyright notice

This document and the information contained herein, is the exclusive property of Verlinde S.A.S and represents a non-public, confidential and proprietary trade secret that may not be reproduced, disclosed to third parties, altered or otherwise employed in any manner whatsoever without the express written consent of Verlinde S.A.S. Copyright 2020 © Verlinde S.A.S. All rights reserved.

#### 1.1.3 Definition of terms

All brand names, product names, and trademarks that are used in these instructions are registered trademarks of their respective owners.



The following terms and definitions are used in these instructions:

<b>ANSI</b>	American National Standards Institute
<b>Authorized personnel</b>	Persons who the owner authorizes and who have the necessary training to carry out operation or service actions.
<b>CE marking</b>	The CE marking indicates that the product complies with the appropriate CE regulations.
<b>Chain hoist</b>	A machine for lifting and lowering the load.
<b>Check</b>	A visual and functional assessment (not a test) of the product without dismantling.
<b>Controller</b>	The pendant controller or other type of controller that the operator uses to give commands to the product.
<b>Electrical panel</b>	The power to the motors is controlled through the electrical panel.
<b>Emergency brake</b>	A brake that the operator can apply or that is automatically applied upon loss of power.
<b>Experienced service technician authorized by the manufacturer</b>	A person with service experience who is authorized by the manufacturer to perform service actions.
<b>Inching</b>	Making very small movements of the crane by repeatedly and momentarily pressing the direction control.
<b>Inspection</b>	Looking for defects and checking the operation of the controls. Limiting and inspecting devices without loading the product. An inspection is more than a check. The inspection process does not normally require any part of the product to be dismantled, other than for removal or for opening of the covers or the housings.
<b>ISO</b>	International Organization for Standardization
<b>Main isolation switch</b>	The main isolation switch is the power switch that the operator should normally use to turn power off or on.
<b>Operator</b>	A person operating the product to handle loads.
<b>Power supply</b>	The power is supplied to the motors through the power supply.
<b>Qualified personnel</b>	Workers with necessary qualifications that are based on theoretical and practical knowledge of hoists. A qualified person must be in a position to assess the safety of the installation together with the application. Persons with the authority to undertake certain product maintenance work include the service engineers of the manufacturer and trained fitters with a corresponding certification.
<b>Rated capacity</b>	A load that the product is designed to lift for a given operating condition (for example, configuration, position of the load).
<b>Runway</b>	The product travels or runs on top of the runway or under the runway.
<b>Sling</b>	A sling is used to attach the hook to the load when the load cannot be lifted directly by the hook.
<b>Trolley (for hoisting machinery)</b>	The hoisting trolley supports the hoisting machinery, and travels along the main girder or the runway.

### 1.1.4 Symbols used in the instructions

Familiarize yourself with the following symbols that are used in these instructions.



Symbol	Description
	Indicates that the product slows down or moves at its slowest speed.
	Indicates that the product accelerates or moves at its highest speed.
NOTE	Indicates items which require special attention by the reader. There is no obvious risk of injury that is associated with notes.

## 1.1.5 Available technical documents

A set of technical documents is available for this product. The documents serve different purposes and audiences. Contact your supplier if you require any of the documents that are listed here.

<b>Mechanical drawings</b>	Describe the mechanical design information of the product
<b>Electrical drawings</b>	Describe the electrical design information of the product
<b>Certificates</b>	Describe that the product is in conformity with the directives and that it is manufactured according to the standards. The certificates also display testing results.
<b>Log book</b>	Consists of records of the usage and service history
<b>Spare part manual</b>	Includes part numbers for all supplied spare parts

**NOTE** *Store the documents in a safe, dry place where they can be easily located when required.*

## 1.2 About this product

### 1.2.1 Use of the product

The product for general use is an entity which has been designed to perform common lifting and lowering operations within the limits that are specified by the duty class of the product (see chapter Hoist duty class). The hoisting machinery for general use may only be modified or used for any other purpose with the written approval of the manufacturer.

The hoisting machinery for general use is suitable for use in general manufacturing only. It is not suitable for use in harsh environments. For more information, see chapter Operating conditions. When in doubt, contact the manufacturer or the representative of the manufacturer.

The product must be positioned directly above (perpendicular to) the load so that there are no side-pulling forces.



#### RISK OF PROPERTY DAMAGE

**NOTICE**

**Side pulling accelerates wear on the hoisting machinery.**

**Never allow the product to be used to pull or drag a load sideways. Always lift the load clear of the ground before performing any traveling movements.**

## **DANGER**

 	<p><b>GENERAL HAZARD</b></p> <p>Unauthorized use of the product could lead to death, severe injury, or property damage.</p> <p>The product may only be used for lifting people with the approval of the manufacturer. The manufacturer must declare in writing that the product may be used for lifting people.</p>
--	---

Modifying the product without the permission of the manufacturer can be dangerous and invalidate the guarantee of the product. Any fundamental modifications to the product must be authorized in writing by the manufacturer. Examples of such modifications include:

- Welding or otherwise attaching new items to the product
- Attaching devices for special material handling such as turning the load
- Alterations to load-bearing components
- Alterations to drives and speeds
- Replacing major items such as trolleys.

**RISK OF PROPERTY DAMAGE**

**NOTICE**

The product may be damaged.

Modifications or additions to the product structures or performance values are only permitted with the approval of the manufacturer.

**RISK OF PROPERTY DAMAGE**

**NOTICE**

The product may be damaged.

Never use the chain hoist as an earth reference for welding.

**RISK OF INVALIDATING GUARANTEE**

**NOTICE**

The product guarantee is invalidated.

The manufacturer does not take any responsibility for accidents which happen as a consequence of unauthorized modifications.

Modifications to the product are allowed only with the approval of the manufacturer.

### 1.2.2 Terms of warranty

The terms under which seller's equipment and/or services are warranted are defined pursuant to the warranty set forth in the contract between seller and customer for seller's products and/or services and, if not so set forth, the warranty for seller's products and/or services is seller's standard warranty in effect at the time of sale, a copy of which is available from seller upon request. THE FOREGOING REPRESENTS THE SOLE AND EXCLUSIVE WARRANTY GIVEN BY SELLER AND IS IN LIEU OF AND EXCLUDES ALL OTHER WARRANTIES, EXPRESS OR IMPLIED, ARISING BY OPERATION OF LAW OR OTHERWISE, INCLUDING BUT NOT LIMITED TO ANY IMPLIED WARRANTIES OF MERCHANTABILITY OR FITNESS FOR A PARTICULAR PURPOSE.

Seller provides no warranties for products manufactured or services provided by parties other than seller ("Third Party Products"). Modifying any seller product or incorporating any Third Party Product into any seller product or service without the seller's approval invalidates warranty. Seller does not accept, shall not have any responsibility and disclaims any liability for accidents, injury or physical or property damage arising as a consequence of such unauthorized modifications and/or incorporation of Third Party Products.

Further, e.g. each of the following invalidates any warranty of seller and relieves seller from any responsibility and liability for accidents, injury or physical or property damage: failure to operate and/or maintain products in accordance with the applicable installation and/or operator's manuals, owner's manuals, maintenance manuals, recommendations, and any other manuals, guidelines or recommendations concerning the maintenance and operation of products that may be communicated from time to time; side-pulling of load; shock loading; excessive jogging; eccentric loading; overloading; accidental occurrence; improper repair; improper handling or storage of products; chemical exposure; abnormal operating conditions not identified to seller in writing prior to seller's issuance of a quotation; or any other cause that in seller's sole discretion is not attributable to defects in material and workmanship.

## 1.2.3 Identification of the product

Information on the technical specification of the product can be found on the data plate of the product. For example, the serial number of the product is stated on the data plate. The data plate of the electrical chain hoist can be found on the hoist frame. This chapter gives more detailed information about the use of the product according to the technical specification.

### Data plate for CE labeled chain hoist

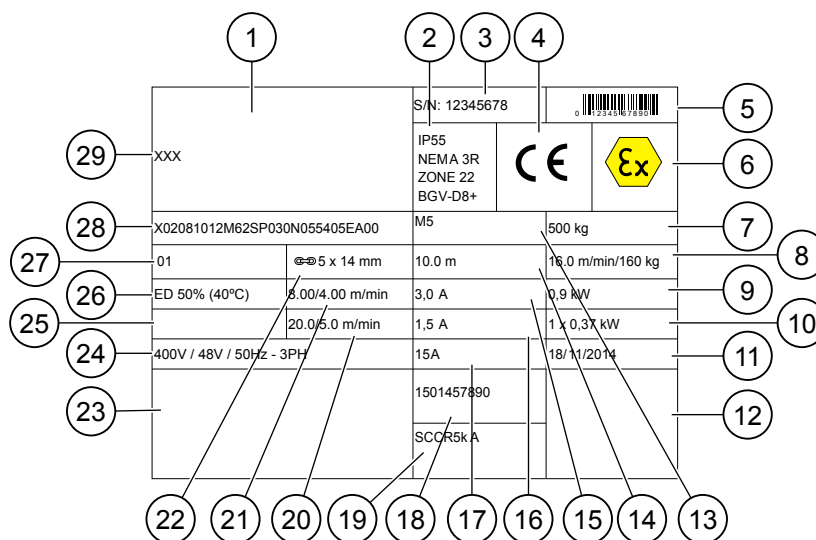

Figure 1. CE data plate for chain hoist

Pos.	Marking	Description
1	Brand	Brand logo
2	Protection class	Protection class type for enclosures, explosive atmosphere markings, hoist safety standard
3	Serial number	A unique product identification number
4	Certification type	CE or EX-marking, depending on the hoist configuration
5	Bar code	Bar code of the serial number
6	Certification type	CSA or EX-marking, depending on the hoist configuration
7	Load	Maximum load that can be lifted with the product
8	ESR speed and maximum ESR load	Extended Speed Range speed and maximum load that can be used to reach the maximum speed
9	Power of hoisting motor	Power output of the hoisting motor

Pos.	Marking	Description
10	Power of traveling motor	Power output of the traveling motor
11	Manufacturing date	Manufacturing day/month/year
12	Empty space	
13	Hoist duty class	Hoist duty class according to standards
14	Lifting height	Maximum height of the lifting motion
15	Rated input of hoisting motor	Rated input of current to the hoisting motor in amperes
16	Rated input of traveling motor	Rated input of current to the traveling motor in amperes
17	Fuse	Rating of the fuse for the main power supply
18	Manufacturer reference	Sales order number
19	Fault current information	Suitable for use on a circuit capable of delivering not more than 5 kA RMS symmetrical amperes (SCCR 5 kA)
20	Traveling speed	Highest and lowest traveling speed
21	Hoisting speed	Highest and lowest hoisting speed
22	Chain type	Diameter and pitch of the chain used
23	Manufacturer	Name and full address of the manufacturer
24	Electrical information	Rated input in main voltage, control voltage, frequency, number of phases (1 or 3 phases)
25	Trolley type	Type of the trolley used in the product
26	Motor duty rating	A ratio of motor on-to-off time with the stated temperature
27	Reeving	Number of falls
28	Designation of series or type	Product type code
29	Product type	Designation of the machinery

**NOTE** *The example data in the figure is shown for illustration purposes only and does not necessarily match the data of your product.*

### 1.2.4 Standards and directives

This product has been designed and manufactured to conform to European and international standards and directives.

The product also fulfills the requirements of the following standards (if applicable): CSA, UL, OSHA, CCC

Declaration of conformity and other certificates are included in the delivery package.

**NOTE** *Manufacturer reserves the right to modify the design and material specifications without prior notice.*

### 1.3 Contact information

Contact the manufacturer's local representative or

Verlinde S.A.

2, Boulevard de l'Industrie

BP 20059

28509 VERNOUILLET CEDEX

FRANCE

[www.verlinde.fr](http://www.verlinde.fr)

## **2 HEALTH, SAFETY AND THE ENVIRONMENT (HSE)**

### **2.1 Safety messages and signals**

This section includes explanations of the safety symbols, signs, signals, and labels used on the product and in the documentation.

#### **2.1.1 Signal words**

The following signal words and symbols are used to identify safety messages in these instructions.



Indicates an imminently hazardous situation that, if not avoided, will result in death or serious injury.



Indicates a potentially hazardous situation that, if not avoided, could result in death or serious injury.



Indicates a potentially hazardous situation that, if not avoided, could result in damage to property or environment.

#### **2.1.2 Hazard symbols**

Hazard symbols are used to indicate the type of the hazard and the potential consequences. Hazard symbols are indicated by a yellow triangle with black symbols and a black triangle band that is surrounded by a yellow border. All personnel working on or in proximity of the machine must understand and follow the information that is given in all hazard symbols.

##### **General hazard symbol**



The general hazard symbol identifies important safety messages in this manual. When you see this symbol, carefully read and understand the message that follows, and inform other users when necessary.

## Mechanical hazard symbols



Foot crushing hazard



Hand crushing hazard



Cutting hazard



Falling hazard



Falling load hazard



Slipping hazard



Falling objects hazard



Crushing hazard



Hanging load hazard

## Electrical hazard symbols



Electrical hazard



Overhead power line hazard

## Noise hazard symbols



Noise hazard

### 2.1.3 Mandatory action symbols

Mandatory action symbols specify actions to be taken to avoid a hazard. Mandatory actions are indicated by white symbols on a blue background. All personnel working on or in proximity of the equipment must understand and follow the information that is given in the mandatory action symbols.

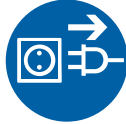

Disconnect equipment from power source.



Wear approved hearing protectors.



Read instructions.



Wear approved safety shoes.



Switch off and lock-out equipment.



Wear approved hard hat.



Wear approved eye protector.

### 2.1.4 Prohibited action symbols

Prohibited action symbols indicate actions that are prohibited in order to avoid a hazard. Prohibited actions are indicated by a red circle with a red diagonal line across the circle. The action that is prohibited is always in black. All personnel working on or in proximity of the equipment must understand and follow the information that is given in the prohibited action symbols.



Do not modify

### 2.1.5 Product safety labels

#### Classification sticker

The classification sticker informs you about the usage classification of the product. The purpose for which the product can and may be used for depends on the classification that is given for the product and its use.

This product may have the following usage classifications depending on the product configuration.



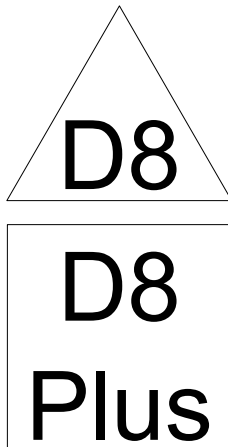

Figure 2. Classification stickers D8 and D8 Plus

Safety label	Description
D8	A chain hoist with the D8 classification can be used to lift loads during set-up.
D8 Plus	A chain hoist with the D8 Plus classification can be used to lift loads during set-up, and hold loads in resting position above people.

## 2.2 Responsibilities of the owner

### 2.2.1 Preventing work-related hazards

The owner of the product must ensure that the operators have a sufficient knowledge of the work-related hazards and of the ways to avoid the hazards.

The operator must always perform a local risk assessment before every work phase or shift. The assessment ensures that the operator stops and thinks about what to do before starting to work.

- Identify potential hazards that could affect you, your colleagues, the environment, your product, or work method while you are performing the task
- Assess the risks and implement the actions that are needed to eliminate or reduce the risks

Only competent persons are allowed to carry out operation and other tasks. The responsibility of the owner is to:

- Provide training and orientation
- Validate training methods
- Verify competence and skills
- Monitor and evaluate user performance regularly

### 2.2.2 Personal protective equipment

**NOTE** *This section proposes personal protective equipment to ensure the operator's safety. Follow the local regulations and requirements of the working environment. Use only approved and accepted personal protective equipment.*

For safety, the operator or others near the product are required to wear personal protective equipment (PPE). Various types of PPE are available as listed below and must be selected according to the requirements of the working environment.

- Hard hat
- Eye-protector
- Hearing protectors
- Safety shoes
- Respirator
- Safety gloves
- Protective clothing
- Safety harness when working at heights
- High-visibility clothing

Do not wear loose clothing or jewelry that can get caught on controls or pulled into moving parts of the product.

Tie back long hair. Long hair can get entangled.

Select the appropriate clothing for each task, for example:

- Wear fire-resistant clothing when welding, flame cutting, or using an angle grinder
- Tear-resistant clothing must resist damage from sharp edges in the steel structure
- Wear anti-static clothing when working on electrical circuits so that components do not get damaged by a discharge of static electricity
- When working with lubricants, clothing must prevent direct skin contact with the lubricant
- Choose the clothing with consideration to the temperature at the working site

### **Fall protection**

While personnel are doing installation, inspection, or maintenance work at heights, they must follow fall protection procedures as required by local regulations. Fall prevention practices and fall protection equipment aim at protecting personnel working on or around the equipment from exposure to falls.

If the equipment does not have a service platform or guardrail, personnel must use a properly fitted safety harness. The safety harness is attached to the dedicated fixing points on a building or equipment in order to prevent falls.

If the product does not have dedicated fixing points for fall protection, it is the owner's responsibility to make sure that suitable and secure fixing points are available or provide an appropriate manlift.

If ladders must be used, personnel must practice setting and securing the ladders before using them for actual work.

Fall protection system has four components:

- **Safety harness:** Safety harness helps to prevent employees to get hurt in a fall.
- **Lanyard belt:** Lanyard belt is connected to the anchor point and is attached to the safety harness. Lanyard belts are shock absorbing, which means that they slow down and eventually stop a fall.
- **Snap hook:** Snap hooks connect the D-ring to the safety harness. Snap hooks must be double locking. The basic rule is: connect only one snap hook to one D-ring.
- **Anchorage point:** Anchorage point is the point to which personal fall protection equipment is attached. The point must be capable of supporting at least 2,268 kg (5,000 lb) per employee. If there is any doubt about the strength of the attachment point, find an alternative point that can support the worker.

A typical fall protection program may include:

- Documented and established site policies and procedures
- Conducting site assessments for fall hazards
- Selection of the proper fall protection system and equipment
- Training on fall protection procedures and the proper use of fall protection systems

- Inspection and proper maintenance of fall protection equipment
- Measures to prevent falling objects
- Rescue plans

If necessary, contact your supplier or service organization for assistance with designing your fall protection program.

### 2.2.3 Incident reporting

Product safety issues that you must report are events in which the manufacturer's product has been involved in an accident or near-miss incident. Contact your local manufacturer's representative immediately to report any safety-related feedback, such as unauthorized modifications, missing manuals and safety labels, neglected maintenance, or misuse.

Reporting is mandatory to ensure safe working conditions for employees, to provide information for the risk assessment process, and to initiate product improvements.

## 2.3 Conditions for product use

### 2.3.1 Operating conditions



#### **WARNING! MACHINE MALFUNCTION HAZARD**

**Using the equipment in an environment for which it is not designed can be dangerous. It also reduces the equipment lifetime and increases the maintenance requirements.**

**Only use the product in an environment for which it is designed for. When in doubt, contact the manufacturer or the representative of the manufacturer.**

If the operating environment deviates from the environment that is specified when you order the product, contact the manufacturer of the product. Solutions are available to enable the product to work in a wide range of operating environments. If you plan to use the product in exceptional ambient conditions or for handling dangerous substances, consult the manufacturer or the representative of the manufacturer. For example, molten metal is considered a dangerous substance. Examples of exceptional ambient conditions include windy areas, zones prone to earthquakes, and corrosive atmospheres.

The product that is designed for general use may be used in normal industrial environments which fulfill the following conditions:

- Indoor products must be situated indoors, protected from outdoor weather conditions.
- Ambient temperature is specified in the order confirmation. Typically it is between -20°C (-4°F) and +40°C (104°F).
- Air quality meets the requirements of the EN standard 14611-1 1999.
- Product is not exposed to any corrosive chemicals or an explosive atmosphere.
- If the product is used in an area prone to earthquakes, special hazards may appear if there is an earthquake.
- Product performance and capacity are designed for altitudes of less than 1000 m (3280 ft) above sea level. Using the product in higher altitudes decreases its performance.
- Relative air humidity must not exceed 90%.

**NOTE** *There can be extra optional features in your equipment to allow operation in special environments such as outdoors. When in doubt, contact your manufacturer or the representative of the manufacturer.*

### 2.3.2 Prohibited use



**WARNING! MACHINE MALFUNCTION HAZARD**

Using the product outside the limits of its duty class or operating conditions could cause malfunction of the product and lead to death, severe injury, or property damage. Only use the product within the limits of its duty class or operating conditions.

Prohibited use of the product includes, but is not limited to the following:

- Using the product in areas with a potentially explosive atmosphere
- Exceeding the maximum working load
- Using the product for lifting or transporting people
- Transporting a load with people nearby
- Moving or holding loads above people
- Pulling a load loose
- Dragging or towing a load
- Pulling a load at an angle, or dragging a load. Always lift, pull, and tension in a straight line between the load and chain hoist.
- Removing the safety latch from the hook
- Touching the chain during the hoisting motion
- Making knots in load ropes or chains or shortening them with devices such as bolts or screws
- Lifting the load with the slack end of the load chain
- Operating the product when the chain is twisted
- Operating a damaged product
- Manipulating the slipping clutch
- Approaching the slipping clutch in normal operation
- Using the product as an earth reference for welding.

For more information, see chapters Product description and Operating conditions. When in doubt, contact the manufacturer or the representative of the manufacturer.

**2.3.3 Changes to the product**

<b>WARNING</b>	
 	<p><b>MACHINE MALFUNCTION HAZARD</b></p> <p><b>Unauthorized changes or modifications to the product could lead to death, severe injury or property damage.</b></p> <p><b>Always contact the manufacturer to get advance written approval for any product change or modification.</b></p>

All modifications and corrections not authorized in the product manuals or which may affect the maintenance, operation, safety, and availability of the product need to be approved in writing by the manufacturer before implementation. Approval requires risk assessment taking into consideration any new risks that the changes and modifications may bring.

Changes and modifications without proper risk assessment, elimination or reduction of risk and without appropriate safety measures may lead to death, serious personal injuries or damage to property or environment. Unauthorized modifications will also void the warranty.

If a modification or correction as described above has been implemented without the manufacturer's permission, its effect on warranty liability will be considered case-by-case. Thus, the warranty application may be rejected altogether. Should you consider a modification or alteration necessary, you must contact the organization that manufactured and designed the product. No modification is permitted unless you first obtain the written approval of the manufacturer.

## 2.4 Safety devices



### WARNING! MACHINE MALFUNCTION HAZARD

Removing or modifying the safety devices could cause malfunction of the safety devices, which could lead to death, severe injury, or property damage.

Do not remove or modify any safety devices on the equipment without written approval from the manufacturer.

### 2.4.1 Hoist

Device	Description
Emergency stop button	The emergency stop button is used to turn off power to the system in dangerous situations. The emergency stop button cuts the supply voltage to the system from the main contactor. Always eliminate the danger before releasing the emergency stop button. There are several types of emergency stop buttons, but they are always red.
Slipping clutch	The slipping clutch protects the machinery against overloading. Overload occurs at around 110% of the rated capacity of the hoist. When activated (at around 150% - 160% static load), the slipping clutch prevents further hoisting but it is still possible to lower the load. Never use the slipping clutch to assess the weight of the load.
Secondary brake (holding brake) (option)	If the hoisting brake fails, the secondary brake (holding brake) supports the load. The secondary brake closes just after the hoisting brake, and opens just before the hoisting brake. For more information, see chapter Checking the brake lining.
Upper and lower mechanical or magnetic limit switch	If the hook moves too high or low, the mechanical or magnetic limit switches prevent the possible damage to the equipment. When the chain stop touches the limit switch or is close to the hoist frame, the limit switch is activated. The activation of the limit switch stops the hook movement. The upper limit switch stops the upward hook movement, and the lower limit switch the downward hook movement. However, it is not recommended to use the mechanical or magnetic limit switches as operational end stops.

## 2.5 Protective measures

### 2.5.1 Emergency stopping



### WARNING! UNCONTROLLED MOVEMENT HAZARD

Emergency stopping could cause the equipment to move or operate in an uncontrolled manner which could lead to death, severe injury, or property damage.

Only use the emergency stop button in an emergency situation.

In an equipment malfunction or other emergency situations, you can stop all motions immediately by pressing the red emergency stop button. In normal operation, do not use the emergency stop button. Instead, use the direction controls. Routinely using the emergency stop button increases wear on the product.

**NOTE** *Only operate the equipment if you know the location of the emergency stop button.*

There are two main types of emergency stop buttons:

- Emergency stop button with a twist-release mechanism which latches in the activated position
- Emergency stop button with a push-pull mechanism which remains pushed in

To reset the latching type of an emergency stop button, twist the button in the direction of an arrow in the mushroom head. The rotating movement releases the latch and allows the button to spring out to the normal reset position.

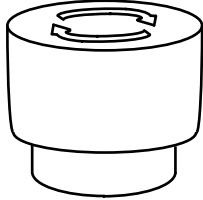

Figure 3. Emergency stop button with twist-release mechanism

To reset the push-pull type emergency stop button, pull the button manually outwards to the normal reset position. The push-pull type emergency stop button is an emergency stop button that does not have a rotation arrow sign on the button head.

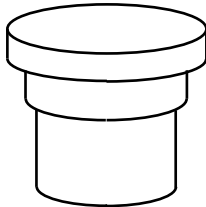

Figure 4. Emergency stop button with push-pull mechanism

Restarting the equipment and the operation controls is possible only after the emergency stop button has been reset to the normal reset position.

## 2.5.2 Main isolation switch

You can only operate the product when power is turned on. The owner must identify and document the location and function of the main isolation switch and communicate this information to all operators.

**NOTE** *Only operate the product if you know the location of the main isolation switch.*

### WARNING! ELECTRIC SHOCK HAZARD



Even though one switch is turned off, there may still be voltage present in some parts of the product. The voltage can result in exposure to electric shocks, which could lead to death or serious injury.

Be aware of the main isolation switch functionality.

### WARNING! SWINGING LOAD HAZARD



Turning off the main isolation switch causes sudden loss of power. The sudden loss of power could cause the load to swing, which could lead to death, serious injury, or damage to the product or load.

Avoid turning off the main isolation switch during load movement.

### 2.5.3 Lockout-tagout-tryout procedure

Before installation, inspection, and maintenance, the power sources must be de-energized, isolated, locked out, and tagged out. Lockout-tagout-tryout procedures are primarily intended to protect the personnel. The procedures prevent accidental starting of the machinery or exposure to electric shocks.

Follow the lockout-tagout-tryout procedures in accordance with the local regulations and the documented site lockout-tagout-tryout procedure. The owner must ensure that the operators are fully aware of the applicable lockout-tagout-tryout procedures.

The following items are normally included in the documented lockout-tagout-tryout procedure:

- Communication requirements - who to inform before using lockout-tagout-tryout procedure
- When the use of lockout-tagout-tryout procedures is permitted
- Identification of each of the switches, controls, valves, and other energy isolating devices present at the site. Role of each device should also be explained.
- Lockout-tagout-tryout procedure sequences that are to be followed before, during, and after maintenance
- Safety and operational considerations regarding other products on the same runway or on adjacent runways.

#### **WARNING! STORED ENERGY HAZARD**



**When the equipment is switched off, there may still be stored energy in the electrical rotating parts, linearly moving parts, or in the load. Unintended release of energy could cause death, severe injury, or property damage.**

**Prevent the unintended release of energy by following the approved lockout-tagout-tryout procedures.**

#### **WARNING! MACHINE MALFUNCTION HAZARD**





**Operating the product while it is under installation or maintenance could lead to death, severe injury, or property damage.**

**Never attempt to operate a control, switch, valve, or other device when it is locked out or tagged out.**

To lock out, tag out, and try out the equipment:

1. Turn off the equipment and disconnect power.
2. Place a personal lock and tag on controls to prevent their use until you remove the lock.
3. While performing the work, always keep the key to the lock with you.
4. If more than one person locks out the same machine, use individual locks and approved multi-lock devices.
5. Verify the absence of voltage with an approved voltage test equipment.
6. Verify the isolation of other forms of energy with an approved method.
7. Attempt to operate the machine or equipment using normal controls. If properly isolated or immobilized, no equipment or system starts nor any part activates or moves.
8. Release energy that may cause danger during the work in a safe way.
9. After completing the work, remove all locks and tags.



**2.5.4 Fire safety**

 <b>WARNING</b>	
 	<p><b>FIRE AND EXPLOSION HAZARD</b></p> <p>Ignition sources, such as smoking, open flames, welding work, and sparks, together with combustible materials, such as fuel, can cause fire and, if not avoided, could lead to death or severe injury.</p> <p>Ignition sources are prohibited in the vicinity of the machine.</p> <p>During maintenance, follow appropriate fire prevention and protection measures, including but not limited to trained personnel, proper fire extinguishing equipment and agents. Before starting any maintenance or repairs that require ignition sources, such as welding or flame cutting, carry out a proper risk assessment to control the risk.</p>

- Smoking and open fire are prohibited in the vicinity of the product.
- Access to all fire-fighting equipment must be granted at all times, especially during maintenance and repair works.
- All fire-fighting equipment must be inspected and serviced regularly, according to local regulations.
- Damaged fire-fighting equipment and used fire extinguishers must be replaced immediately.
- Know the various types of fires and the appropriate fire-fighting methods. Various fires must not be extinguished with water. In most cases special extinguishing agents, dry powders or deoxygenating agents are required.
- All personnel must be trained regularly in fire-fighting methods, in cooperation with local authorities and rescue organizations. If there is a fire, the fire alarm must be activated and all available personnel must help with fire-fighting according to the predetermined fire plan of the workplace.

**2.6 Emissions**

**2.6.1 Noise**

 <b>WARNING</b>	
 	<p><b>NOISE HAZARD</b></p> <p>Continuous exposure to noise above 80 dB(A) could cause hearing impairment. Wear approved hearing protectors.</p>

**Sound pressure levels**

Hoists generate some audible noise during operation. The total sound pressure level that is experienced in the operating area is a combination of the individual noise sources around the operator. The main sources of noise from the hoist arise from its components, vibrating structures and reflective surfaces.

Hoist components which generate noise:

- Hoisting machinery
- Trolley, bridge, or other moving structures associated with the hoist.



When the distance between the operating location and the hoist and associated moving components is more than 5 m (16 ft), the average combined sound pressure level due to the hoist and its associated components does normally not exceed 65 dB(A) at the operating location. The sound pressure level rises as the operator moves closer to the sources of noise.

The sound pressure level can exceed 65 dB(A) if, for example:

- Operator operates the hoist from somewhere close to the moving components
- Crane or building structures resonate heavily
- Walls or other surfaces at the working site reflect noise towards the operator
- Optional warning devices are functional



### Measured sound levels

The sound pressure level and volume measurements in the operator station have been performed according to ISO EN 11201.

The A-weighted sound pressure level at the operator station (during operation)	LpA 65 dB or below
--	--------------------

The estimated uncertainty for determination of A-weighted sound pressure levels and sound power levels (standard deviation of the reproducibility of the measurements) is 4 dB (ISO 4871-1996).

## 2.7 Personnel requirements

 <b>WARNING</b>	
 	<p><b>SPECIALIST SKILLS REQUIRED</b></p> <p><b>Incompetent operation and maintenance procedures could cause death or severe injuries.</b></p> <p><b>Operation and maintenance procedures require professional skills and special training regarding the tasks and working methods.</b></p> <p><b>Do not operate the equipment or do any maintenance tasks without proper training. Always follow the instructions. Use appropriate personal protective equipment, depending on the task.</b></p>

To avoid hazardous situations and dangerous consequences, leave all operation and maintenance work to professionals. The tasks that are mentioned here are examples of tasks which are allowed only for trained personnel. More details on the risks that are related to the tasks can be found in the chapters where the procedures are instructed. The instructions also contain information on how to carry out the tasks safely. Tasks that require special technical skills and training include, but are not limited to, electric system maintenance.

## 2.8 Environmental information

Environmental impacts have been taken into account in designing and manufacturing this product. To prevent environmental risks during use, follow the instructions and local regulations for disposal of waste material. Proper use and maintenance improve the environmental performance of this product.

### 2.8.1 Product life cycle stages

Product life cycle stages include:

- Production of materials and components
- Equipment manufacturing and assembly
- Use phase, including maintenance and modernization
- Dismantling and recycling of waste materials
- Deliveries between each stage

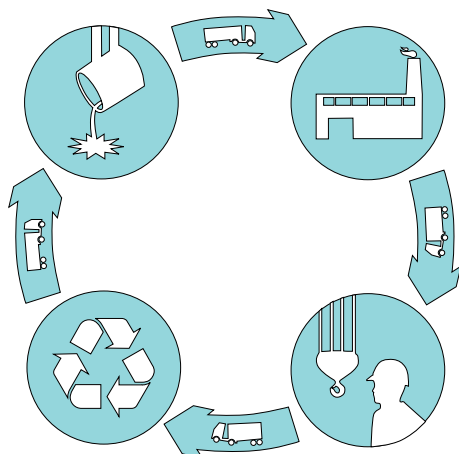

Figure 5. Product life cycle stages

### 2.8.2 Handling waste material

Handle and dispose of the waste material from installation, maintenance, or dismantling according to local regulations. From the sustainability point of view, the preferred waste handling methods are reuse, recycle as material, energy recovery and, as a final resort, safe disposal.

As waste regulations and types of recovery and disposal methods vary regionally, no common, detailed guidance can be given. The following list provides proposals for adequate waste handling methods.

**NOTE** *Always use licensed recycling companies.*

Table 1. Waste handling methods

Material	Waste handling method
Metals	Recycle the metals.
Electronics and electromechanical components	Some electrical parts may be treated as hazardous waste. Collect and recycle the electronics and electromechanical components separately.
Batteries	Batteries and other energy storage components may contain hazardous substances. Collect these items separately and recycle according to local regulations.
Plastics	Recycle plastic as material, use it for energy recovery, or deliver it to a landfill site.
Chemicals	Never spill chemicals, such as oil, grease, and other liquids, onto the ground, soil, or sewage. Store waste oil and grease in containers that are indicated for the purpose. More detailed information on chemical handling as waste can be found in the chemical's safety data sheet that is available from the manufacturer of the chemical.

<b>Material</b>	<b>Waste handling method</b>
Packing materials	Reuse or recycle packing materials, such as plastics, wood, and cardboard.
Rubber	Recycle rubber according to local regulations.  Whenever possible, return the used rubber tires to the tire supplier for recycling.

**3 PRODUCT DESCRIPTION**

**3.1 Technical data**

**3.1.1 Hoist duty class**

When the product is designed and purchased, the predicted lifetime of the product is agreed, based on the expected use of the product. This expected use is known as the duty class. A hoisting machinery which is used continuously and to lift heavy loads is clearly in a different duty class than a hoisting machinery of the same size which is used occasionally and to lift light loads. When the product is used in accordance with the designed duty class, the expected lifetime should be reached.

The owner is responsible for ensuring that the product is used according to the duty class that the product has been designed for. By doing so, the product should reach the original predicted lifetime.

**RISK OF PROPERTY DAMAGE**

**NOTICE**

**Operating the product outside the limits of the specified duty class raises the risk of mechanical failure and can shorten the lifetime of the product.**

**Do not allow the product to be used outside the limits of the specified duty class.**

The duty class is based on many factors, including hardware, predicted lifetime, number of shifts and lifts, distances traveled, ratio of heavy to light items that are lifted, and the environmental conditions that the product is used in. Note that if you move from single-shift working to three-shift working, you have to reduce the loads that are lifted or the distances that are traveled (or both) to remain within the requirements of the duty class.

Parameter	Variables
Lifting height and working distances	Actual hoisting time and the average distances being traveled by the trolley and lifting devices
Operating environment	The product is designed to work within specific parameters of temperature, humidity, and cleanliness.
Product process	Number of shifts
	Number of work cycles in an hour and the average lifted loads

Authorized service personnel must check periodically whether the product is used according to the defined duty class. The owners and operators should recognize that any changes to the product usage that are left unchecked may result in an increase of the overall maintenance costs and a considerable decrease of the safe operating lifetime of the product. Changes to any of the parameters and variables can require that the duty class must be revised.

If there are significant permanent changes in the product usage, authorized service personnel must revise the duty class and design working period (DWP) as necessary. Changes to hardware or servicing frequency may be required.

## 3.2 Functional description

### 3.2.1 Functional principle of the electrical chain hoist

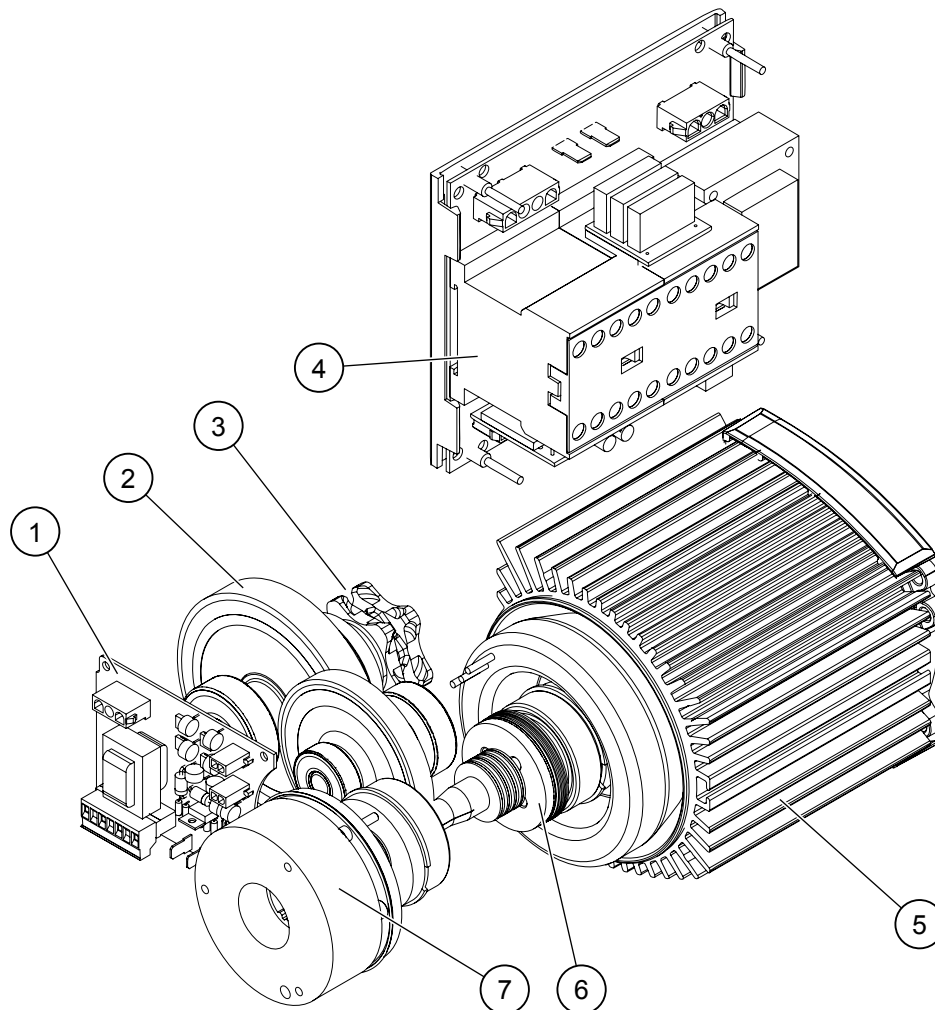
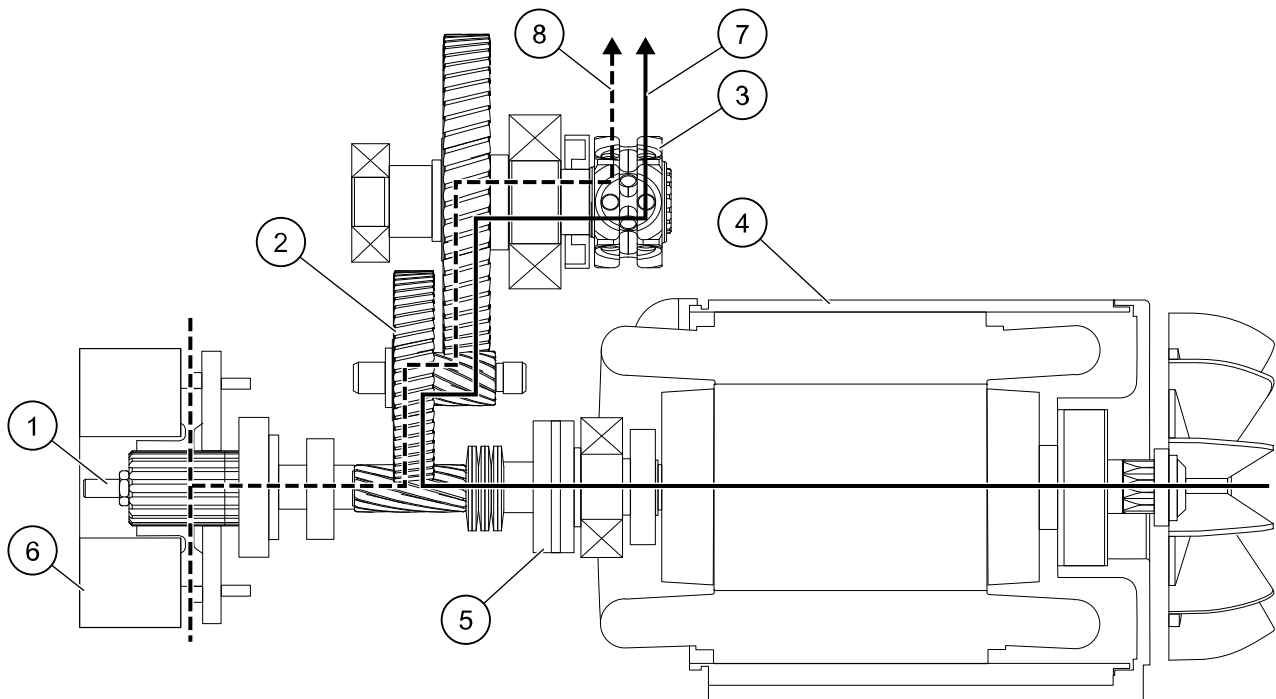

Figure 6. Main components of the lifting function

- |   |  |
|---|--|
| 1. Electrical panel 1 (configuration A) | 5. Hoisting motor                      |
| 2. Hoisting gear                        | 6. Slipping clutch                     |
| 3. Chain sprocket                       | 7. Brake (single brake in the example) |
| 4. Electrical panel 2 (configuration B) |  |

### 3.2.2 Kinematic chain for electrical chain hoist



- |                     |                    |
|---------------------|--------------------|
| 1. Adjustment screw | 5. Slipping clutch |
| 2. Hoisting gear    | 6. Brake           |
| 3. Chain sprocket   | 7. Motor torque    |
| 4. Motor            | 8. Brake torque    |

#### Motor torque path

The motor (4) rotates the axle, which makes the hoisting gear (2) helical steps turn. The gear reducer transfers the motor power over the chain sprocket (3) to the chain, which then moves according to the selected direction (up or down).

The assembly includes a slipping clutch (5) that allows to lift loads that correspond to 110% of the nominal rated capacity. The slipping clutch prevents the hoist from lifting loads that exceed 160% of the rated capacity. An overload slips the slipping clutch, allowing the motor to continue running and preventing the hoist from taking an overload that can damage the hoist.

#### Brake torque path

The brake (6) is always electrically disengaged when the motor (4) works. As soon the motor stops, the brake engages and blocks the rotation of the hoisting gear components and the chain sprocket.

## 3.3 Chain hoist

### 3.3.1 Key parts of the chain hoist

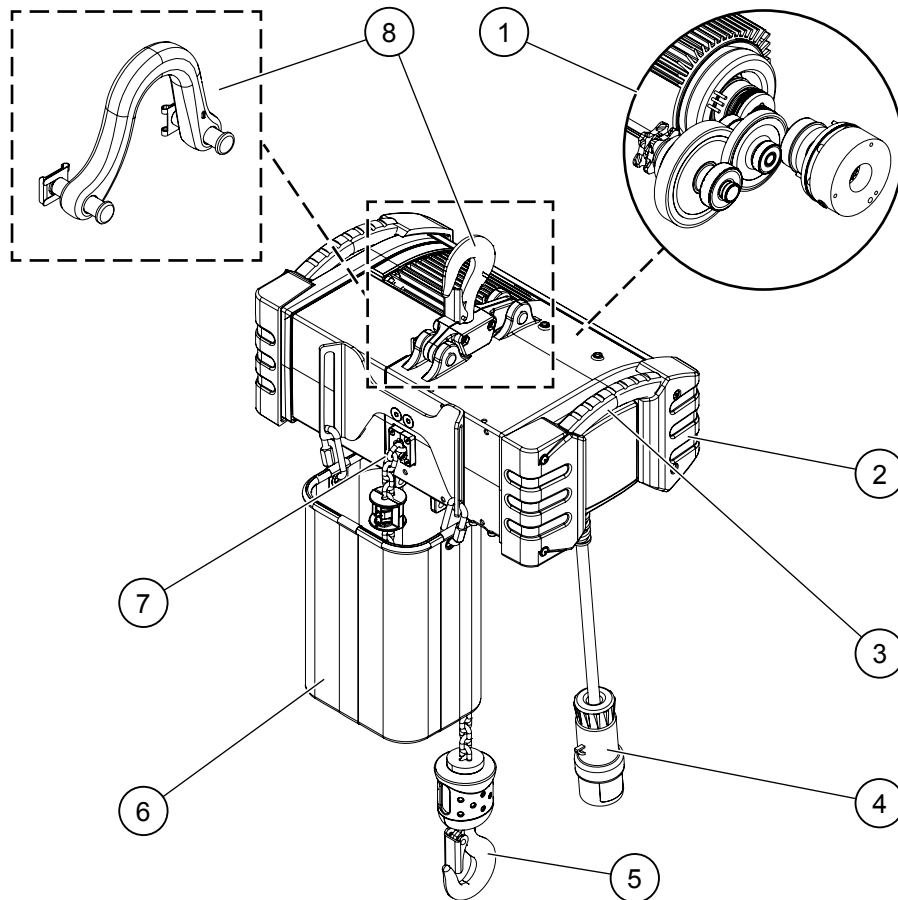

Figure 7. Main components of the electrical chain hoist

- |                           |  |
|---------------------------|--|
| 1. Hoisting machinery     | 6. Chain bag   |
| 2. Buffer                 | 7. Chain guide   |
| 3. Handle                 | 8. Suspension (rotating suspension hook or bracket suspension) |
| 4. Control cable and plug |  |
| 5. Hook                   |  |

### 3.3.2 Chain drive

The chain drive consists of the following components: the chain guide, chain sprocket, and chain.



The chain is specially designed for the use in chain hoists. The chain is made of a high-strength and ageing-resistant material, and the standard color of the chain is black. The dimension tolerances of the chain have been precisely adapted to the chain drive.

**NOTE** *To ensure a safe operation of the chain hoist, it is recommended to use only a genuine chain. Use a chain that is provided by the manufacturer of the chain hoist.*

To reach the maximum service life of the chain, the chain must be lubricated regularly according to the instructions. When you replace the chain, it may be necessary to replace also the chain drive, either partly or completely.

## 3.4 Controller

The layout of the direction controls may vary from product to product. The function of each direction control is indicated by a symbol. It is important that the operator knows the meaning of each symbol to be able to operate the product safely.

 <b>WARNING</b>	
	<p><b>UNINTENDED MOVEMENT HAZARD</b></p> <p>Pressing an incorrect control button on the controller can lead to unintended movements of the product. Unintended movements can result in death, serious injury, or serious damage to the product.</p> <p><b>Make sure that you press the correct control buttons on the controller for the intended movements of the product.</b></p>

### 3.4.1 Pendant controller

You can control the lifting movement of the chain hoist by using a pendant controller which is plugged to the product.

## 3.5 Options

### 3.5.1 Manual brake release

The manual brake release feature is available as an option. This feature allows you to release the brake by hand in situations where you must lower the load manually.

The manual brake release should only be used in emergency situations where the brake cannot be released normally. Extensive use of the manual brake release and high lowering speed can result in immediate wear-out of the brake lining. Note the following warnings that are related to the use of the manual brake release.

**NOTE** *Extensive use and high lowering speed can make the brake lining wear out immediately.*

**NOTE** *Before using the hoist again, make sure that the manual brake release is stored safely.*



**WARNING! ELECTRIC SHOCK HAZARD**

Contact with live parts could cause death or severe injury.

Make sure that the hoist is not connected to any source of electricity. Also check that the electricity cannot be activated accidentally.



**WARNING! FALLING LOAD HAZARD**

Operating the product with people underneath or near the load could cause a falling load hazard. A falling load could cause death or serious injury to the people situated underneath or near the load.



When operating the product, make sure that there are no people who are situated underneath or nearby the load.

### Using the manual brake release

Use the manual brake release to lower the load manually in situations where the brake cannot be released normally.



1. Place the manual brake release lever (1) on the brake (2). Insert one arm of the lever into the brake gap (3) on the left side of the upper screw (4).

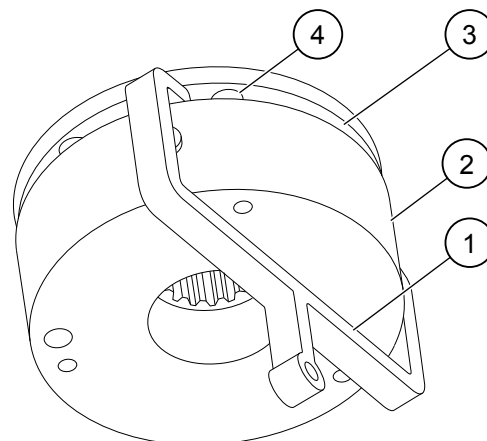

2. Turn the manual brake release lever so that its second arm fits into the brake gap on the opposite side of the brake.

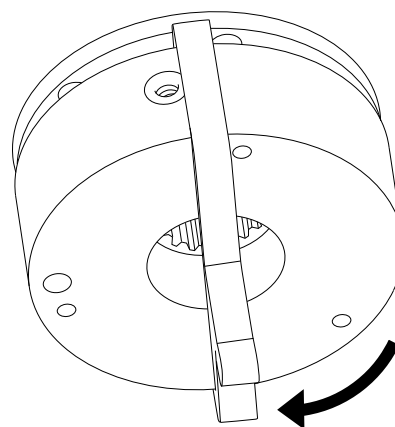

3. Tilt the manual brake release lever in the brake gap. Press the lever carefully to open the brake. Do not open the brake for more than one (1) second before stopping again.

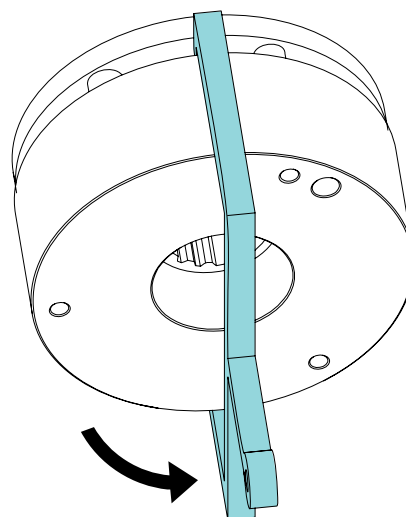

4. Repeat the procedures for pressing the lever and lowering the load within short intervals.

### 3.5.2 Rotating geared limit switch

The rotating geared limit switch is available as a 2-step or 4-step version. The rotating geared limit switch option is available only for the chain hoist configuration B.

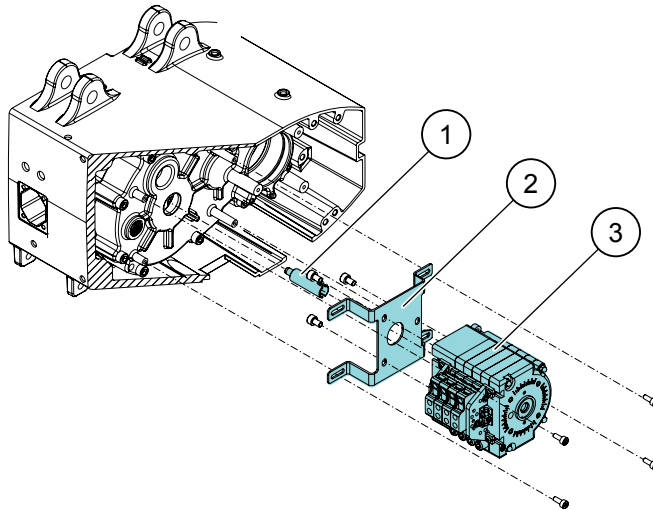

Figure 8. 4-step rotating geared limit switch

- |                 |                                 |
|-----------------|---------------------------------|
| 1. Coupling     | 3. Rotating geared limit switch |
| 2. Fixing plate |                                 |

### Rotating geared limit switch types

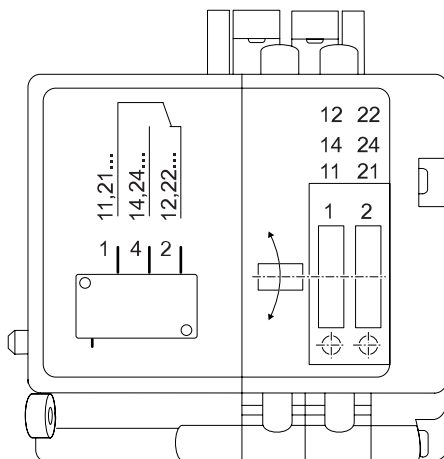

Figure 9. 2-step rotating geared limit switch

The 2-step rotating geared limit switch works together with the internal controls as an adjustable upper and lower stop limit. It is mechanically connected to the hoisting gear and counts the revolutions of the chain sprocket. The internal gear ratio of the geared limit switch must be designed according to the total stroke of the chain hoist.

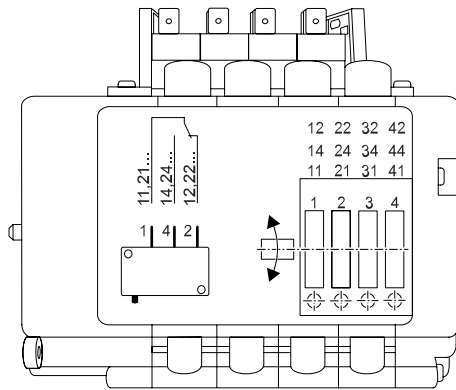

Figure 10. 4-step rotating geared limit switch

The 4-step rotating geared limit switch has a similar operating function as the 2-step geared limit switch, but provides four separately adjustable switching units. There are several configuration possibilities for this feature, but the configuration 1 (see table 4-step geared limit switch) is the standard configuration.

## Rotating geared limit switch configurations

### 2-step geared limit switch

Config.	GLS type	Description	Switch unit
1	<b>2-step GLS + microswitch or magnetic limit switch 1)</b>	Limit switch safety UP stop	Switch X3A 2)
		Limit switch safety DOWN stop	Switch X4A 2)
		Limit switch working UP stop	GLS UP 1
		Limit switch working DOWN stop	GLS DOWN 1
2	<b>2-step GLS + microswitch or magnetic limit switch</b>	Limit switch UP stop	Switch X3A 2)
		Limit switch DOWN stop	Switch X4A 2)
		Slow speed UP	GLS UP 1
		Slow speed DOWN	GLS DOWN 1

1) Standard configuration.

2) The switches X3A and X4A are electro-mechanical limit switches that are installed on the chain guide. They are activated mechanically when touched by the buffer of the hook.

### 4-step geared limit switch

Config.	GLS type	Description	Switch unit
1	<b>4-step GLS + microswitch or magnetic limit switch <sup>1)</sup></b>	Limit switch safety UP stop	Switch X3A <sup>2)</sup>
		Limit switch safety DOWN stop	Switch X4A <sup>2)</sup>
		Limit switch working UP stop	GLS UP 1
		Limit switch working DOWN stop	GLS DOWN 1
		Slow speed UP	GLS UP 2
		Slow speed DOWN	GLS DOWN 2
2	<b>4-step GLS + microswitch or magnetic limit switch</b>	Limit switch safety UP stop	Switch X3A <sup>2)</sup>
		Limit switch safety DOWN stop	Switch X4A <sup>2)</sup>
		Limit switch working UP stop	GLS UP 1
		Limit switch working DOWN stop	GLS DOWN 1
		Free for customer use	GLS UP 2
		Free for customer use	GLS DOWN 2
3	<b>4-step GLS + microswitch or magnetic limit switch</b>	Limit switch UP stop	Switch X3A <sup>2)</sup>
		Limit switch DOWN stop	Switch X4A <sup>2)</sup>
		Slow speed UP	GLS UP 1
		Slow speed DOWN	GLS DOWN 1
		Free for customer use	GLS UP 2
		Free for customer use	GLS DOWN 2
1) Standard configuration.			
2) The switches X3A and X4A are electro-mechanical limit switches that are installed on the chain guide. They are activated mechanically when touched by the buffer of the hook.			

## **4 INSTALLATION**

### **4.1 General instructions for installation**

### **4.2 Safety during installation**

1. Ensure that the installation personnel are professionally competent, qualified, and are provided with adequate instructions for carrying out the work.
2. Ensure that the test loading, test drive, and commissioning have been executed properly. Check that the handover log has been completed properly.
3. Ensure that components, electrical connections, and steel structures of the product have been inspected and certified as defect-free.
4. Check with your supplier that you have received all the relevant documents for the product delivery. Check that the documents correspond to the product you have received.
5. Ensure that tools and equipment are available for installation, in accordance with the sales contract. To prevent objects from falling when working in high places, use proper safety equipment.
6. Ensure that sufficient time has been reserved for installation and testing.
7. Prevent unauthorized persons and bystanders from walking on or below the work site. Components or tools may fall and result in injuries. To prevent injuries from falling components or tools, ensure that the secured area is spacious enough.
8. Ensure that there is no possibility for personnel or body parts to be struck, crushed, or compressed by moving machinery:
  - Secure the area so that installation personnel are not at risk from the movements of machines, automatic doors, or adjacent cranes at the installation site.
  - Ensure that machinery and equipment cannot start accidentally or move during installation and maintenance phases.
  - To reduce the risks, maintain sufficient space in the operating area.
  - To prevent entrapment, shield moving parts with guards.
  - Never override any safety devices.
  - Be prepared in case equipment moves in the wrong direction during testing.
9. Check that the supply voltage and frequency match the requirements of the equipment. Check that the installed busbars are suitable for the equipment.
10. Before allowing the equipment to be used for normal operation, ensure that all safety devices have been restored to their full operational status. Safety devices may have been bypassed for testing purposes. Never bypass a safety device for normal operation.
11. Ensure that the operating environment and space that is reserved for the equipment is suitable for all functions of the product.
12. Immediately following installation and before commissioning, check that the supplied parts conform to the drawings, instructions, parts lists, and structural measurements. Discuss any non-conformance with the supplier immediately.
13. Items which are not properly secured to the equipment, such as tools or detached components, could move or fall accidentally, with potentially serious consequences. When dismantling the equipment, lower the components to the ground at the earliest practical opportunity.
14. Check for any electrical hazards in and around the operating area and take appropriate steps to minimize them. Only properly trained personnel may perform electrical work on the product and they must use safe methods always.
15. If there is a need for welding to be done at the site, provide suitable fire extinguishers. Do not allow any of the product structure or components to be used for grounding.

## 4.3 Installation preparations

### 4.3.1 Transport, packing, scope of delivery

The product is packed in a box for transportation. Before starting to install the hoist, visually check that the package in which the product has been delivered to you is intact. Also check that the content of the delivery matches with your order. If not, contact your supplier. If the hoist has been stored for a long time or has been transported by sea, check that the motors are dry.

To remove the hoist from the box, first remove the temporary transport supports. The chain bucket is not fixed to the hoist during transportation, so lift the hoist and the chain bucket from the box simultaneously. Note that the chain connects the bucket and the hoist.

#### WARNING! EQUIPMENT DAMAGE HAZARD



If the hoist is used in outdoor conditions, water may be able to collect to the inside of the chain bucket, which could cause damage to the hoist and the chain.

Drill a hole with a diameter (D) of 10 mm (0.4 in) to the bottom of the chain bucket to allow for water to drain. Do the drilling when the hoist is installed, before the chain is placed to the chain bucket, to avoid damaging the chain. The draining hole can only be drilled to chain buckets that are made of hard plastic and steel. It is not possible to use it with chain bags that are made of the soft canvas material.

**NOTE** Do not bundle the chain into the chain bucket.

### 4.3.2 Tightening torques for the chain hoist

Tightening torques [Nm]	
Frame size	05
Component	Torque [Nm]
Gear housing	10
End covers (covers of the chain hoist)	10
Chain guide	10
End shield (motor flange)	10
Counterweight	25
Brake	3.9
Chain end stop	2.9
Hook block	11.5

### 4.3.3 Handling the product

#### Lifting the hoist

To select an appropriate lifting device and prevent overloading, check the weight of the hoist before starting to lift it. The weight of the hoist can be found on the packing list, in the technical documents, or on the hoist data plate.

The hoist is normally lifted using an auxiliary hoist and some kind of a lifting device. The most common lifting devices are chains and lifting belts. Every lifting device must be clearly marked with the rated capacity and must be approved by authorities.

**NOTE** *Always follow the instructions that are provided by the lifting device manufacturer and the local authorities. The manufacturer of the hoist is not responsible for lifting accessories that are provided by other manufacturers.*



**WARNING! FALLING LOAD HAZARD**

Overloading can damage the auxiliary lifting devices. If the device fails, the load could fall and cause serious injury or death.

Only use lifting devices that display clearly the rated capacity and that are approved by the authorities.

Never attempt to lift a load before ensuring that it weighs less than the maximum permitted load of the auxiliary lifting device.

### Lifting points on the hoist

Lift the chain hoist from the suspension bracket. If lifting points are available on the product, they are marked with a sticker.

**NOTE** *Before lifting the chain hoist, read the instructions in chapter Lifting the hoist.*

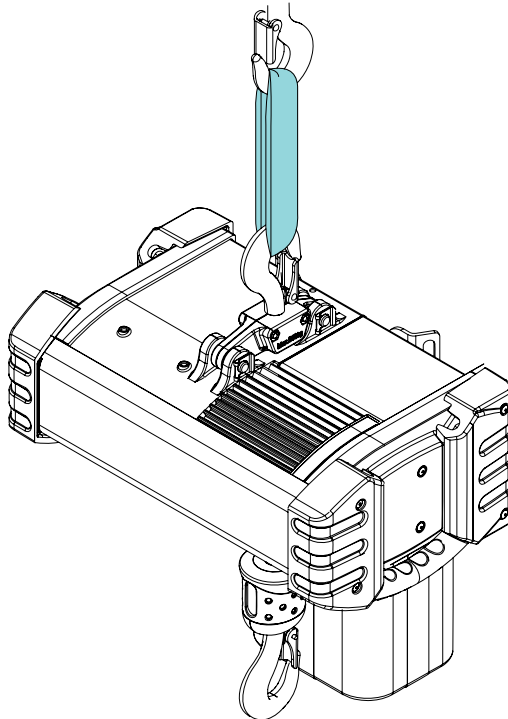
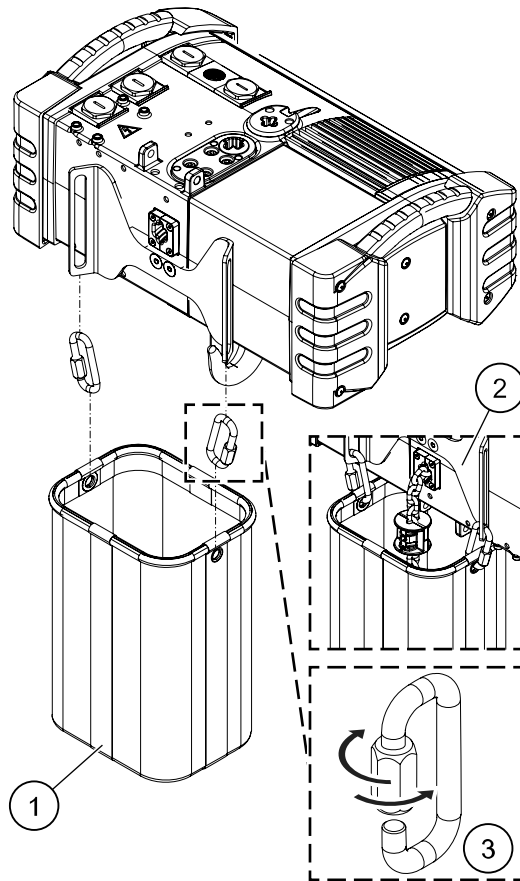

Figure 11. Lifting the chain hoist

## 4.4 Fitting the chain bucket

1. Attach the chain bucket (1) to the connection part (2) with the screw-lock carabiners (3).



### 4.5 Removing and installing the hoist covers

1. Make sure that you have disconnected the chain hoist from the main power supply network.
2. To access the components on the brake side, loosen the four screws of the end cover on the brake side. Remove the end cover.

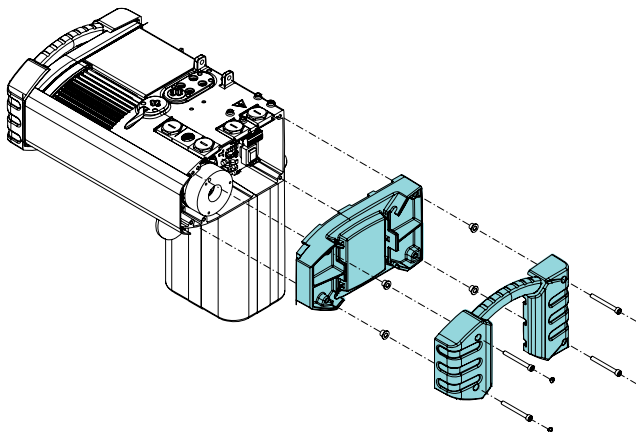

3. To access the components on the motor side, loosen the four screws of the end cover on the motor side. Remove the end cover.



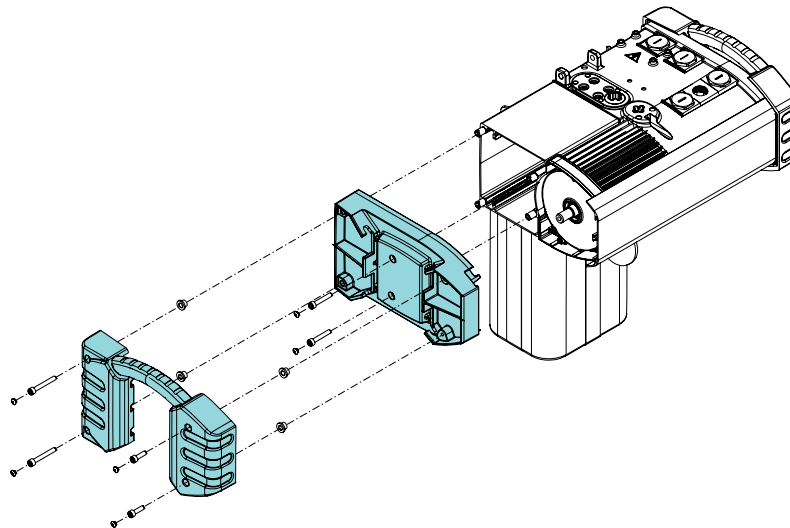

4. To install the end covers, put the end cover back on its place on the hoist frame. Tighten the four screws to the correct tightening torque.  
For more information, see chapter Tightening torques for the chain hoist.

## 4.6 Installation steps

1. Unpack the product. Dispose of the packing material in an environmentally compatible way. For more information, see chapter Handling waste material.
2. Check that the delivery is complete. For more information, see chapter Transport, packing, scope of delivery.
3. Connect the hoist to the power supply. For more information, see chapter Connecting the hoist to power supply.
4. If needed, adjust the lower hook position. For more information, see chapter Adjusting the lower hook position.
5. Before starting to use the product for the first time, follow the instructions that are given in chapter Commissioning. Perform the commissioning checks and test. Before operating the product, perform also the checks that are mentioned in chapter Checks before operating.

## 4.7 Suspending the chain hoist

### **WARNING**

#### **OVERLOAD HAZARD**

Overloaded components may cause malfunctions, which could lead to serious injury, death, or damage to the product.

The suspension or supporting structure of the chain hoist must be designed for the maximum load that is caused by the operation of the chain hoist when the chain hoist is used as intended.

### **WARNING**

#### **FALLING HAZARD**

The chain hoist may fall, which could lead to serious injury, death, or damage to the product.

Do not use chain hoists that have a fixed suspension, such as a suspension hook or suspension bracket, for inclined pull of loads.

The chain hoist must be suspended with an articulated arrangement. Inclined pull must be prevented from rigid suspension arrangements.

### **WARNING**

#### **FALLING HAZARD**

The chain hoist may fall, which could lead to serious injury, death, or damage to the product.

If the suspension type of the chain hoist is a suspension bracket, do not move the chain hoist or leave it unattended when the suspension bracket is open.

### 4.7.1 Supporting structure

According to DIN EN 14492-2, the force limitation factor is  $\phi_{DAL} = 1,6$  for chain hoists with a rated capacity that is greater than or equal to 1000 kg. The supporting structure must be designed to accommodate the static and dynamic forces that occur when the overload protection device is tripped.

According to DIN EN 14492-2, chain hoists with a rated capacity that is greater than or equal to 1000 kg must be equipped with overload protection. This chain hoist is delivered with a slipping clutch that acts directly as an overload protection.

The slipping clutch must be adjusted according to the rated capacity of the chain hoist. For more information, see chapter Adjusting the slipping clutch.

### 4.7.2 Suspension

The suspension type of the chain hoist is either a rotating suspension hook or a suspension bracket. The rotating suspension hook is the standard suspension type, the suspension bracket is available as an option.

### 4.7.3 Attaching the hoist to the supporting structure

### **WARNING**



#### **MACHINE MALFUNCTION HAZARD**

If the suspension bracket is installed incorrectly, the chain hoist hangs at an angle. Suspending the chain hoist at an angle results in premature wear of the chain drive.

Make sure that the suspension bracket is fitted to match the chain reeving arrangement of the chain hoist.



If special fittings are installed on the chain hoist, make sure that they are counter-balanced.

1. Remove the retaining clip and pin on one side of the suspension bracket.
2. Attach the suspension bracket to the supporting structure or to the trolley (if equipped).
3. Insert the pin through the suspension and the suspension bracket. Secure the fixation with the retaining clip.

## 4.8 Electrical connections

### 4.8.1 Cable gland positions on the hoist

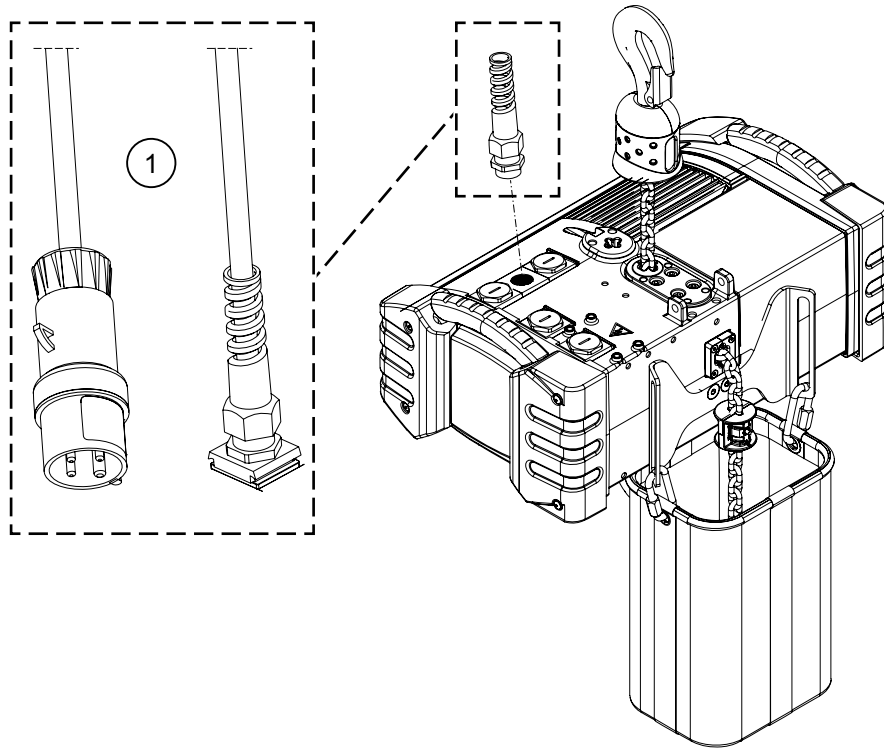

Figure 12. Cable gland positions of the chain hoist configuration A

1. Power supply

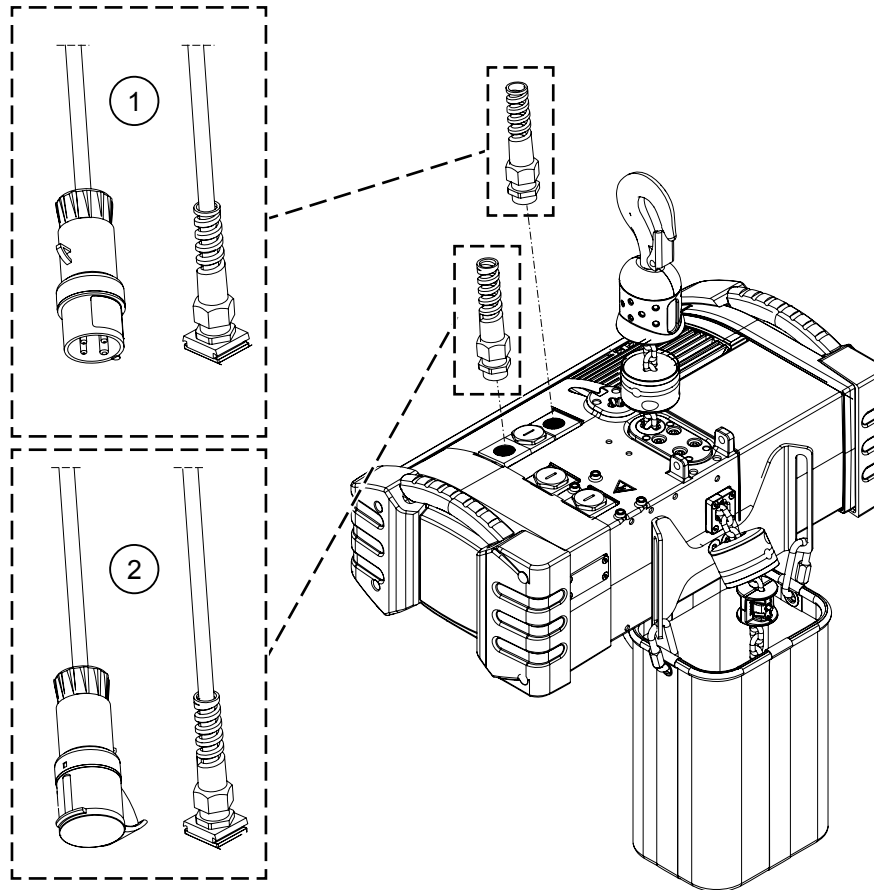

Figure 13. Cable gland positions of the chain hoist configuration B

1. Power supply

2. Control cable

### 4.8.2 Connecting the hoist to power supply

If the chain hoist is ordered without plugs, these instructions show you how to connect the chain hoist to the power supply.

**Before connecting the chain hoist to the main power supply network, check that**

- rated voltages correspond to the main voltage. Check the voltages and frequencies that are marked on the data plate of each product or component. For example, motors that are driven by a frequency converter may have different values on their data plate than the values of the chain hoist.
- power supply to the chain hoist is protected with fuses of correct size.

## WARNING



### ELECTRICAL SHOCK HAZARD

The chain hoist is delivered with a short power supply cable that is attached to the power supply socket. The short power supply cable is only a temporary cable which is not properly insulated. Connecting the temporary cable to the power supply can cause an electric shock, which could lead to death, serious injury, or damage to the product.

Never connect the chain hoist to the power supply using the temporary power supply cable. Remove the temporary power supply cable on the site and replace it with the main power supply cable. Replace the temporary power supply cable before connecting the chain hoist to the power supply.

1. Remove the plug of the power supply cable from the power supply socket. Open the cable gland. Remove the temporary power supply cable by pulling it out through the cable entry and the cable gland.

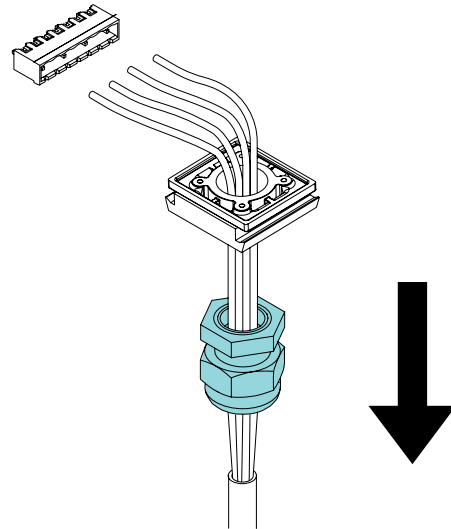

2. Place the main power supply cable through the cable gland and the cable entry. Connect the cable wires to the plug.
  - To ensure the correct phase sequence, pay attention to the order of the wires when connecting them to the plug: Connect the power control board (PCB) connectors L1/L2/L3 with the phases 1/2/3 according to the correct phase sequence.
  - Connect the (yellow and green) grounding wire with grounding (GND).

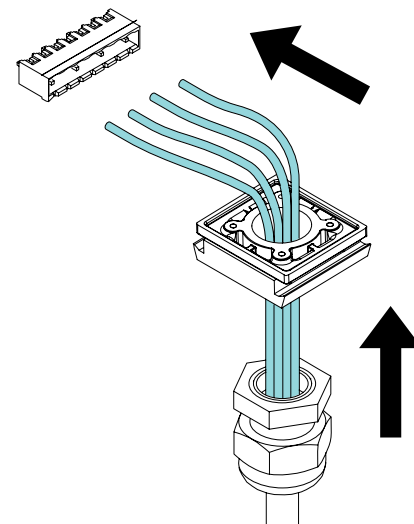

3. Slide the power supply cable assembly in place. Connect the power supply plug to the power supply socket.

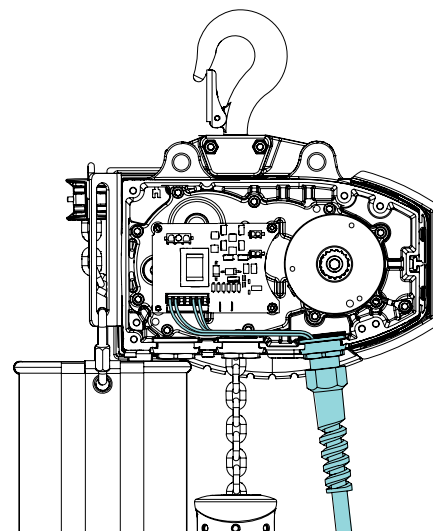

4. Install the end cover. Install the end cover and secure the fixation with the four screws. Tighten the screws to the correct tightening torque.

5. Check that the phase sequence is correct.  
To check the phase sequence, check that all motions (upward and downward movement of the hoist) occur to the correct direction. Check that desired functions are activated when you press the controller buttons UP and DOWN. Check also that the traveling motion directions correspond to the controller directions. If not, change the phase sequence.
6. Check carefully all connections.

### 4.9 Adjusting the rotating geared limit switch

If the hoist is equipped with a rotating geared limit switch, adjust the cutting points (upper and lower limits) of the geared limit switch before starting to operate the hoist. Instructions on how to set the limits in the different geared limit switch configurations can be found on a sticker. The sticker is placed on the hoist profile, next to the geared limit switch adjustment holes.

#### 1. Check the operation of the limit switch

Check the correct operation of the limit switches. Raise and lower the hook at low speed until the limit switches are activated and prevent further upward or downward movement. If the desired function does not activate at the selected position, adjust the limit switches.

#### 2. Adjust the limit switches

After checking the operation of the limit switches, adjust the upper and lower limits if needed. To adjust the limits, access the geared limit switch according to the following instructions.

1. Unscrew the screws (1) of the cover plate of the geared limit switch cams. The cover plate is can be found on the chain bag side of the hoist.
2. Remove the cover plate. Now you can access the adjustment screws of the geared the limit switch.
3. To set the upper (UP) and lower (DOWN) limits, follow the instructions for setting the limits. The instructions are given on the sticker (2) that is placed next to the cover plate of the geared limit switch cams.

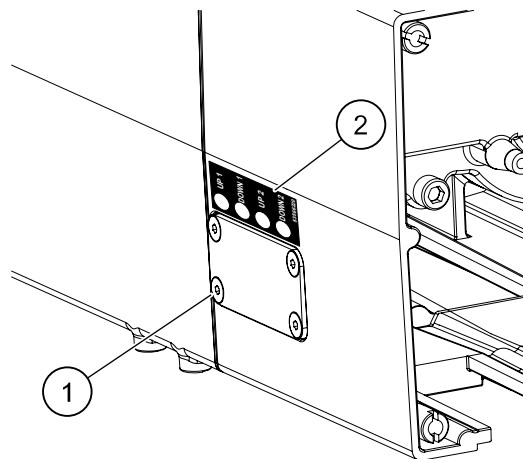

4. Set the limits by turning the set screws 1–4, depending on the number of the switching elements.
  - Turn clockwise: Switching point is moved **upwards**.
  - Turn counterclockwise: Switching point is moved **downwards**.
5. If the limit switches cannot be adjusted, replace the rotating geared limit switch.

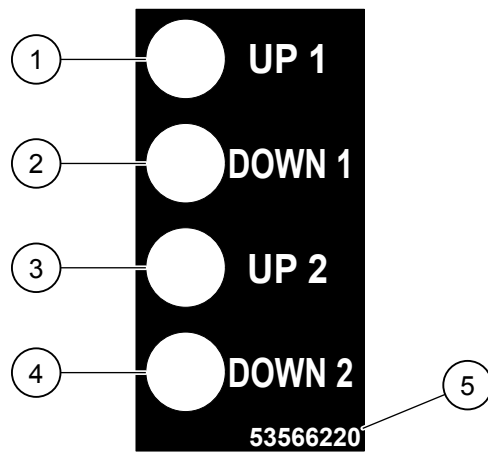

- 1. Upper (UP) limit 1
- 2. Lower (DOWN) limit 1
- 3. Upper (UP) limit 2
- 4. Lower (DOWN) limit 2
- 5. Identification number

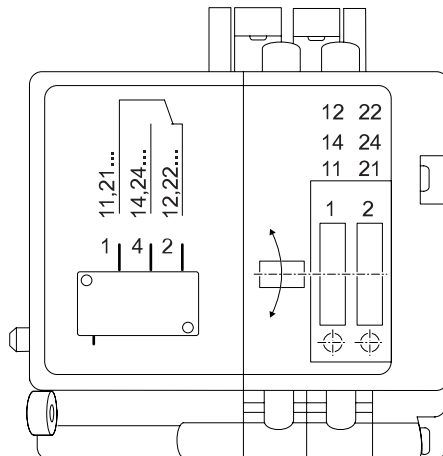

Figure 14. 2-step rotating geared limit switch

The set screw 1 is the upper limit and the set screw 2 is the lower limit.

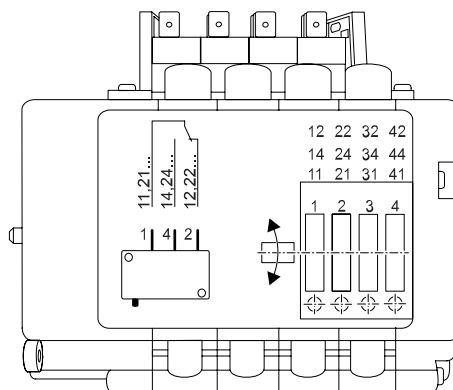

Figure 15. 4-step rotating geared limit switch

The set screw 1 is the upper limit 1 and the set screw 2 is the lower limit 1.

The set screw 3 is the upper limit 2 and the set screw 4 is the lower limit 2.

#### **4.10 Adjusting the lower hook position**

When you determine the hook path or lifting height, ensure that the lower hook touches the ground in the lower hook position. Secure the limit stop to the fifth chain link at the unloaded end of the chain.

To reduce the lifting height, proceed as follows.

1. Drive the hook down to ground level so that the chain is slack.
2. Stop the chain hoist and activate the emergency stop or the main isolation switch. Secure the emergency stop or main isolation switch against switching on again.
3. Remove the chain bucket. For more information, see chapter Removing the chain bucket.
4. Remove the limit stop on the chain bucket end of the chain.
5. Attach the limit stop directly behind the buffer.  
The unloaded chain fall behind the limit stop must consist of at least five chain links.
6. Place the chain in the chain bucket. Attach the chain bucket to the hoist. For more information, see chapter Fitting the chain bucket.
7. Turn on the power to the hoist.
8. Check the adjustment of the lower hook position by moving the hook.
9. Run the chain once through over the entire adjusted hook path.



## 5 COMMISSIONING

### 5.1 Safety during commissioning

- Use personal protective equipment.
- Use fall protection measures.
- Use voltage rated tools VDE EN 60900.
- Use lock and tag out signs to prevent unauthorized use of the equipment.
- Ensure, so far as is reasonably practicable, that the health and safety of people near and around the workplace is not put at risk.
- Ensure, so far as is reasonably practicable, that the workplace is secured from unauthorized access.

### 5.2 Commissioning preparations

- Always consider local regulations for crane commissioning and safety.
- Machines may only be put into operation by qualified personnel.
- Verify that installation of mechanical and electrical equipment is completed according to the SAT (site acceptance test) check list.
- Mark the operating area where you carry out the commissioning driving, test loading, and other tasks.
- Notify other personnel working in the close vicinity.
- Identify possible collision hazards of the crane to structures, obstacles, equipment, or personnel. Take proper actions to limit collision hazards.
- When a manlift is needed, familiarize yourself for device operating and safety instructions before using them.
- Prepare for the load test. Find out the local regulations on how much load is required. Normally the load that is required varies between 90%-130% of the rated capacity.
- Adequate illumination must be available for safe operation. Requirements for illuminating workplaces are laid down in DIN EN 12464.

### 5.3 Commissioning instructions

#### 5.3.1 Checking the hoist before first run

Before running the commissioning tests, check the following items.

1. **Check the supporting structure**
  - Check that the supporting structure is in good condition. Check the load capacity of the chain hoist.
2. **Check the lubrication**
  - The chain hoist is delivered with an unlubricated chain. Initial lubrication is part of the commissioning preparations of a new chain hoist. Lubricate the chain carefully before taking the chain hoist into use for the first time. For instructions, see chapter Lubricating instructions for the chain.





#### **WARNING! MACHINERY MALFUNCTION HAZARD**

**Without the initial lubrication, the chain and other components of the chain drive wear prematurely. Missing lubrication reduces the lifetime of the chain and the complete chain drive drastically. The wearing starts immediately after taking the chain hoist into use. As a result, the chain can fail and cause a machinery malfunction or a load drop. A machinery malfunction or load drop could lead to death, serious injury, or damages to the equipment.**

**Lubricate the chain carefully before the first run and thereafter at regular intervals.**

3. **Check the bolted joints**

- Check the bolted and mechanical connections.
  - Check the connection with the hoist frame and the suspension part.
  - Check the connection with the suspension part and the trolley, if applicable.
  - Torque the bolts with a proper torque wrench. For more information, see chapter Tightening torques for the chain hoist.
4. **Check the electrical connections**
- With the product disconnect OFF, check the proper electrical grounding of the product.
  - Check that the connections of electrical devices comply with the wiring diagrams and meet local requirements. In particular, check connections that affect the safety and controlling of the equipment.
  - Check the condition of wiring and connections.

 <b>DANGER</b>	
	<p><b>ELECTRICAL SHOCK HAZARD</b></p> <p><b>Touching any part of the chain hoist or trolley which has no proper and sufficient grounding can cause an electric shock. An electric shock could lead to death or serious injury.</b></p> <p><b>Make sure that the grounding wire of the power supply cable is always connected to a suitable ground connection. The grounding wire of the power supply cable is either green with a yellow stripe, or solid green.</b></p> <p><b>Do not paint the trolley wheel running surfaces of the beam, as painting can affect the grounding.</b></p>

5. **Check the chain**
- Check that the chain has no damages from the transport and that it is not twisted.
  - Check the condition of the chain stop at the idle end of the chain. Check the condition of the chain stop fixation to the chain.
6. **Check the hook**
- Check the hook visually to ensure that it has no damages from the transport.
  - Check that the hook safety latch is on the hook, is in good condition, and closes automatically.
  - Check that the hook forging rotates freely.
  - Measure the dimension of the hook opening of the the hook and the suspension hook. Note the dimensions for a follow-up as reference values for the hook wear measurement. For instructions on the hook wear measurement, see chapter Measuring wear on the hook.

### 5.3.2 Before lifting

Check that the load is balanced and safely fastened at the lifting points. The load must not be able to slide, slip, or detach itself when suspended. When you begin to lift, check that the load is properly balanced before lifting it high off the ground. If the load is not balanced, lower it down and adjust the lifting point.

- Do not use a lifting device which is unsuitable for the purpose. Only use lifting devices in accordance with the instructions from the manufacturer.
- Do not use a damaged lifting device. Inspect all lifting devices carefully before using them.
- Do not use a lifting device if its rated capacity is not displayed clearly. Only use lifting devices that are approved by the authorities.
- Do not lift a load that is heavier than the rated capacity of the lifting device.
- Do not move the load before ensuring that it is properly attached to the lifting device.
- Keep yourself and bystanders away from the danger zone during lifting. Never place a load over people.

### 5.3.3 Testing the hoist without load

1. **Check the electrical connections**
  - Turn on the power to the chain hoist.
  - Check that the rated voltages correspond to the main voltage.
  - Check that the power supply to the chain hoist is protected with fuses of the correct size.
  - Check that the phase sequence is correct.
  - Check possible fault messages from hoist monitoring unit and inverters (not in all models).
2. **Check the controller**
  - Check that the controller is correctly installed and in good condition.
  - Check the functionality of push buttons, joysticks, and switches.
  - Check that all motions occur to the correct direction.
  - Make sure that desired functions occur when operating the push button, joystick, or switch.
  - Check that the hook movement corresponds to the control direction.
  - Check that the controller does not cause any disturbance to the functioning of other controllers.
3. **Check the emergency stop button**
  - Check the operation and condition of the emergency stop button.

#### WARNING! UNCONTROLLED MOVEMENT HAZARD



Emergency stopping could cause the product to move or operate in an uncontrolled manner. Uncontrolled movements or operation could lead to death, severe injury, or property damage.

Only use the emergency stop button to stop the movement or operation of the product in an emergency situation.

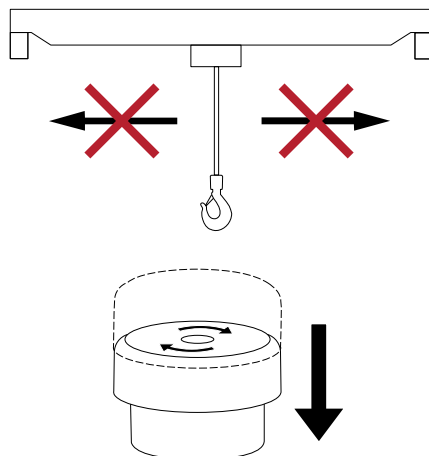

4. **Check the limit switch operation**
  - Check the operation of the mechanical or magnetic limit switches.
  - Check the operation of the rotating geared limit switch.  
Raise and lower the hook at low speed, until the limit switches are activated. When the limit switches are activated, they prevent further upward or downward movement of the hook. If the desired function does not activate at the selected position, adjust the limit switch. If the geared limit switch cannot be adjusted, replace it.
5. **Check the buffers and end stops**
  - Check that the buffer hits center of the end stop.
  - Check that the buffers of the chain hoist are able to bump into the end stops or buffers of another trolley.
6. **Check the operating sound and movements**

- Listen to the operating sounds during lifting or traveling movements. Pay attention to unusual noises such as squealing.
- Check that the chain hoist runs smoothly and without any strong vibration.

### NOTE

***If any defects or abnormalities are detected during the commissioning, they must be investigated and corrected. Investigate and correct the defects and abnormalities according to the instructions that are relevant to the component in question.***

#### 7. Check the slipping clutch operation

- Check that the slipping clutch mechanism works correctly. When the torque caused by load (1) exceeds the designed lifting limit, the clutch discs (2) should begin to slip, preventing the lifting movement.

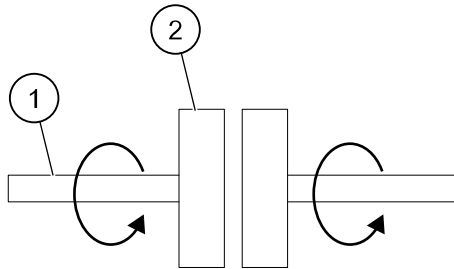

#### 8. Check the brake operation

Check that the hoisting brake operates correctly in both upward and downward directions. The braking distance is normal when it is two chain links or less.

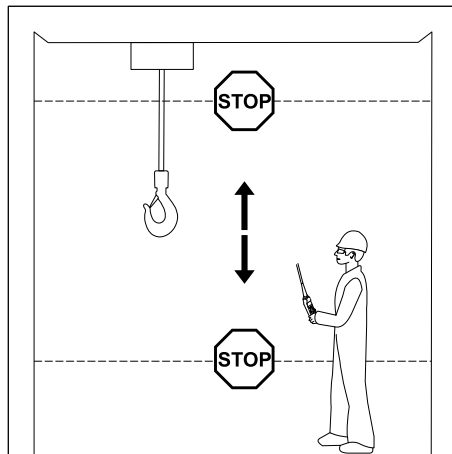

### 5.3.4 Testing the hoist with test load

Before starting to use the product, check that it is used as intended in all possible applications. Check that the product is operated with only the maximum permissible load. Check the operation of the safety devices, for example, by lifting an overload. If the product is not used correctly, check the behavior of the product.

#### 1. Perform the load tests

- Test the product with dynamic and static load tests. Perform the dynamic tests with 110% of the rated capacity. Perform the static tests with 125% of the rated capacity.

**NOTE** *The test load must be securely fastened and properly balanced.*

**NOTE** *Make sure that the hook does not turn around while lifting.*

#### 2. Measure the power supply

- Check that the voltage is over the required minimum value (normally -5 %) under 100% load.

#### 3. Check the brake operation

- Check that the hoisting brake operates correctly in both upward and downward directions. The braking distance is normal when it is two chain links or less.

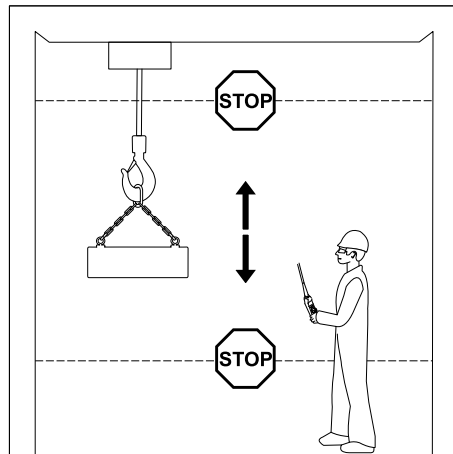

#### 4. Check the motor current

- Check the motor current at each phase during the lifting and lowering motion with the rated capacity. The current should be in balance in all phases, and it may not exceed the ratings for the motor. Check the current with both hoisting speeds.

#### 5. Check the running temperature

- If the thermal protection halts the lifting or lowering movement prematurely, identify the reason for the overheating before continuing the commissioning tests.

#### 6. Check the slipping clutch operation

- Check that the slipping clutch mechanism works correctly. When the torque that is caused by the load exceeds the designed lifting limit (110% [EUR], 125% [US, CH]), the slipping clutch discs should begin to slip. When the slipping clutch discs slip, they prevent the lifting movement.
- Local regulations state the maximum values for the load that can be lifted. Follow the local regulations. Maximum limit for the load that should not be lifted in any case is 1.6 x the rated capacity.

## 5.4 After commissioning

- Check visually that the hoist or any other part has not been damaged in any way during commission testing.
- Check that all tools and materials that are used during installation are removed from the hoist and track.
- Ensure that the hoist operator and supervision personnel are aware of the need for user training.  
Authorized service organization of the hoist manufacturer can arrange user training by separate agreement.
- Check the documents delivered with the hoist.  
Ensure that entries in the documents are properly recorded. Check that the reference data in the documentation matches the data on the data plates.
- Compile a commissioning log for the hoist and store it together with the other documentation for the hoist.

**NOTE** *Local requirements may demand other commissioning testing to be performed before the product can be used. Make sure all the local requirements are fulfilled.*

**NOTE** *All optional features must be tested before using the product.*

## 6 OPERATION

### 6.1 Safety during operation



#### **WARNING! FALLING LOAD HAZARD**

Operating the product with people underneath or near the load could cause a falling load hazard. A falling load could cause serious injury or death to the people situated underneath or near the load.



When operating the product, make sure that no people are situated underneath or near the load.

#### **NOTE**

*Do not deliberately use mechanical limit switches to stop the motion. Always stop the motion with the controls on the pendant controller before reaching the mechanical end limits.*

#### **NOTE**

*If the product malfunctions during use, engage the emergency stop button and contact the supervisor.*

#### **NOTE**

*Motors get hot when they run, even without a load on the hook. Operate the motors at the highest practical safe speed because low speeds generate more heat. Allow the motors to cool down frequently so that they do not overheat. See chapters Hoist duty class and Design working period (DWP) for the maximum permissible continuous operation times. If a motor gets too hot, the thermostat prevents further operation.*

#### 6.1.1 Operating environment

Always operate the product in operating conditions that the product is designed for. For more information, see chapter Operating conditions.

#### 6.1.2 Responsibilities of the operator

The electrical chain hoists are used for various tasks and purposes. They can lift different types of loads, and many different operators use them in different ways of operation. The hoists are often regularly operated by non-dedicated operators, for example as part of the normal work routines and responsibilities of many workers.

Because the manufacturer of the hoist has no direct involvement in or control over the operation and application of the equipment, it is the responsibility of the owner and the operating personnel of the hoist to ensure that the product is operated according to required safety practices. Only authorized and qualified personnel who can demonstrate that they have read and understood the contents of these instructions and that they have sufficient understanding of the proper operation and maintenance of the equipment should be permitted to work with the hoist.



#### **WARNING! IGNORING INSTRUCTIONS HAZARD**

**Failure to follow the given instructions could cause death or serious injury.**



**Read and understand the contents of these instructions before operating, servicing, and maintaining the equipment.**

## 6.2 Movements

### 6.2.1 Controls for movements

The speed corresponds to the position of the direction control. The equipment moves at the slowest speed when the push button is partially pressed and at the maximum speed when the push button is fully pressed. The equipment stops moving when the push button is released.

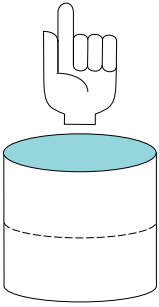
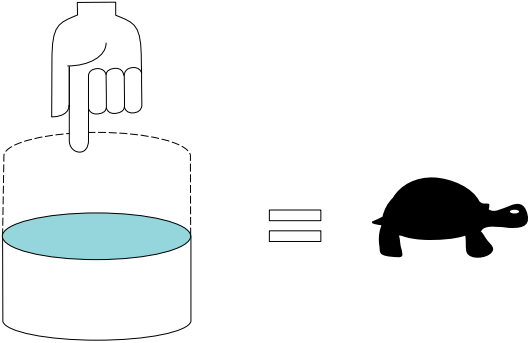
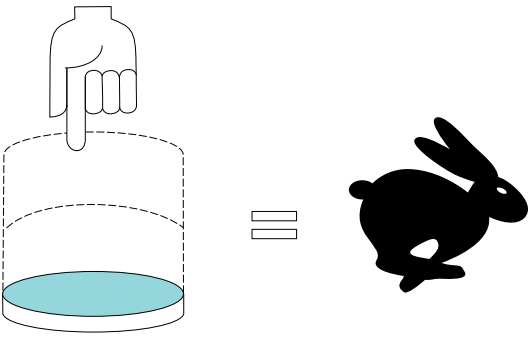
<p>1</p>	<p>When the push button is released, the equipment stops moving.</p>	
<p>2</p>	<p>When the push button is partially pressed, the equipment moves at a slow speed.</p>	
<p>3</p>	<p>When the push button is fully pressed, the equipment accelerates up to the maximum speed.</p>	

**NOTE** *If you press a push button (for example hoist UP) while the opposite direction push button is pressed (for example hoist DOWN), the lifting device does not change direction.*

**NOTE** *Sudden speed changes increase wear on motors and brakes and can cause an overtemperature in the motors.*

### 6.2.2 Motor control methods

Two-speed push button control

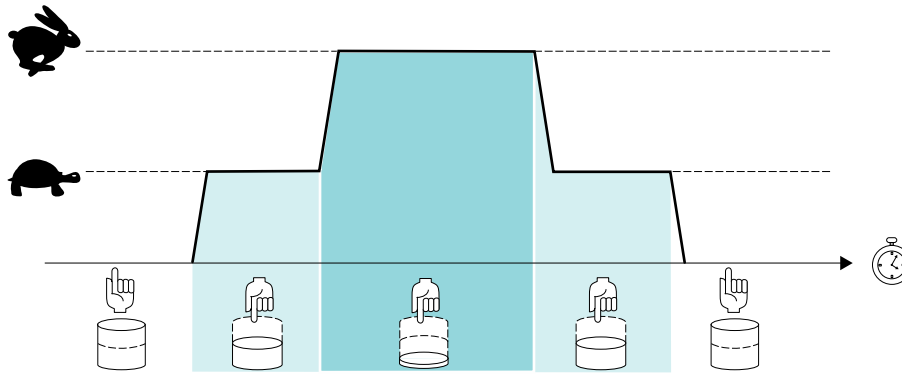

The motor runs at one of two preset speeds corresponding to the force that the operator applies to the direction control push button. When you press the direction control push button half-way down, the motor runs at its slowest speed. When you press the direction control push button fully down, the motor runs at its maximum speed. When you release the direction control push button, the motor stops running.

### EP (Electronic Potentiometer) push button control

<p><b>1</b></p>	<p><b>Released (stop):</b> The device does not move or if it moves already, it decelerates to a complete stop.</p>	
<p><b>2</b></p>	<p><b>Step 1 (slow or maintain):</b> If you press the push button half-way down (step 1), the device accelerates until it reaches the preset slow speed.  If you press the push button half-way down (step 1) when the device moves above the preset slow speed, the motor maintains its current speed without accelerating or decelerating.</p>	
<p><b>3</b></p>	<p><b>Step 2 (accelerate):</b> The device accelerates continuously until you release the push button or reach the maximum speed.</p>	



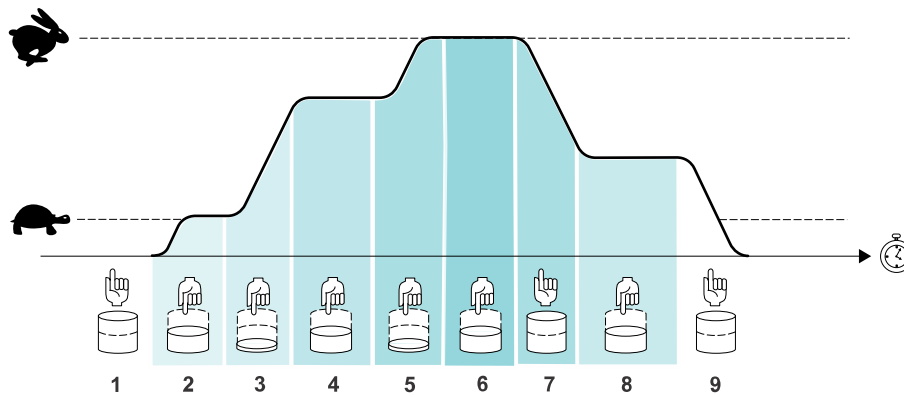

1. Push button released: Motor does not run.
2. Push button step 1 pressed: Motor accelerates until it reaches the preset slow speed.
3. Push button step 2 pressed: Motor accelerates towards maximum speed.
4. Push button step 1 pressed: Motor maintains the current speed.
5. Push button step 2 pressed: Motor accelerates until it reaches maximum speed.
6. Push button step 1 pressed: Motor maintains the current (maximum) speed.
7. Push button released: Motor decelerates.
8. Push button step 1 pressed: Motor maintains the current speed.
9. Push button released: Motor decelerates to a complete stop.

**NOTE** *When you press or release a push button, the movement accelerates or decelerates smoothly. Consider the starting and stopping distances before making any movements.*

## 6.3 Checks before operating

Before every working shift, perform the following checks to ensure that the product is in safe operating condition. By carrying out these simple checks, you can identify potential problems at an early stage, and enhance safety and minimize downtime.



### **WARNING! MACHINE MALFUNCTION HAZARD**

**Operating a product with an abnormal condition or malfunction could lead to serious injury, death, or damage to the product.**

**Do not use the product outside the limits of its duty class or operating conditions.**

**NOTE** *If you notice any abnormal conditions or malfunctions in the product during the daily inspection, report it immediately to your supervisor. Also report any abnormal condition or malfunction that occurs during the daily operation of the product. Remove the product from use. Using the product may only continue when a safe operation of the product is ensured.*

### 6.3.1 Checking the hoist before every working shift

Before every working shift, check the general condition of the equipment and the working environment.

1. **Check the operating environment**  
Check the operating environment visually to make sure that there are no (new) hazards that can prevent the safe use of the product.
2. **Check the condition of the hoist**  
Check the general condition of the hoist.
3. **Perform visual checks**  
Check the hoist visually to see that there are no oil leaks from the hoist or other equipment.

#### 4. Check the operation of the emergency stop button

Check that the emergency stop button can be pressed down and that it stays in that position.

**NOTE** *Never operate the product if it is locked or tagged out.*

#### 5. Check the chain

- Check the chain visually for any deformations, damage, or twisting.
- Check the chain for cleanness and correct lubrication. For lubrication instructions, see chapter Lubrication.

#### 6. Check the hook

- Inspect the hook for nicks, gouges, and twisting. Check the throat opening of the hook for deformation. Also inspect the hook for wear on the saddle or load bearing point.
- Check that the hook rotates freely.

#### 7. Check warning signs

Check that all warning signs are in place. Check that the warning signs are in good condition and can be read easily.

### 6.3.2 Checking the operation with the emergency stop button pressed down



#### **WARNING! UNCONTROLLED MOVEMENT HAZARD**

If the emergency stop button is faulty, the product might move unexpectedly during the following checks. Unexpected movements during checks could cause serious injury or death.

**Do not stand in the danger zone.**

1. Turn on the main isolation switch.  
The product becomes operational (energized).
2. With the emergency stop button pressed down, check that the equipment does not move when you press the direction control push buttons.  
If the equipment does not move, it verifies that the emergency stop button works properly.
3. Check for smooth mechanical operation of each push button, joystick, or isolator on the controller.

### 6.3.3 Checking the operation with the controller enabled

Perform the following checks before every working shift. The checks must be done with the emergency stop button released and the power to the chain hoist switched on.



#### **WARNING! UNCONTROLLED MOVEMENT HAZARD**

Releasing the emergency stop button and operating the product when it is unsafe could cause serious injury or death.

**Never release the emergency stop button and operate the product until you are sure that it is safe to do so.**

#### 1. Check the warning devices

Check that all warning devices work correctly before starting to use the product. Check the indicator lights, LEDs, displays, gongs, bells, alarm horns, alarm sirens, and beacon lights.

#### 2. Set up the controller

Set up the controller. For instructions, see chapter Setting up the controller.

#### 3. Check the brakes

Check that the brakes operate in all directions and that the speed increases as it should do in relation to the control.

#### 4. Check the noises

Listen for unusual noises.

5. **Check the mechanical or magnetic limit switch operation**

Check the upper and lower mechanical or magnetic limit switches.

1. Check the condition of the rubber plate on top of the hook. The rubber plate activates the mechanical or magnetic upper and lower limit switches on the chain hoist. If the rubber plate is damaged or not in place, the limit switches do not operate correctly.
2. Check the correct operation of the limit switches by raising and lowering the hook at low speed. When you raise and lower the hook, drive the chain from one end to the other.

6. **Check the geared limit switch operation (if equipped)**

If the chain hoist is equipped with a rotating geared limit switch, check the operation of the limit switch. The cutting points (upper and lower limits) of the geared limit switch must be adjusted before starting to operate the chain hoist.

1. First check the operation of the limit switch. For instructions, see chapter Testing the hoist without load.
2. After checking the operation of the limit switch, adjust the upper and lower limits. For instructions, see chapter Adjusting the rotating geared limit switch. If the limit switches cannot be adjusted, the rotating geared limit switch must be replaced.

7. **Check the hook safety latch**

Check to ensure that the hook safety latch is in place on the hook. Check that the hook safety latch is in good condition and that it closes automatically.

## 6.4 Starting the equipment

### 6.4.1 Setting up the controller



**WARNING! UNCONTROLLED MOVEMENT HAZARD**

Releasing the emergency stop button and driving the hoist when it is unsafe could cause serious injury or death.

Never release the emergency stop button and drive the product until you are sure that it is safe to do so.

To enable the use of the controller, do the following steps:

1. Make sure that the main isolation switch is in the position ON.  
The hoist becomes operational only (energized) after connection between the product and controller has been established.
2. If applicable, use the key switch to turn on the controller.
3. To prepare the controller for operation, release the emergency stop button.  
To release the emergency stop button, turn it clockwise. If the emergency stop button is a push-pull type button, release it by lifting the button up to the raised position.
4. Energize the product by pressing the start push button (if equipped).

The controller is ready for the operational checks.

## 6.5 Load handling

### 6.5.1 Load handling methods

#### Evaluating the load

To prevent overloading, determine the weight of the load before lifting. Lift the load only when you are sure that it weighs no more than the maximum permitted load of the product and its accessories.

Do not use the overload device of the lifting equipment to determine whether the load can be lifted. Overload devices, such as the slipping clutch, are not accurate enough to determine whether a load can be lifted. A load which does not trigger the overload device may still be heavier than the maximum permitted load.



**WARNING! FALLING LOAD HAZARD**

Lifting a load that weighs more than the maximum permitted load of the equipment and its accessories can cause the device to fail. If the device fails, the load can fall and cause death or serious injury.



Never attempt to lift a load that is heavier than the rated capacity of the lifting devices. Never use an overload device to determine whether the load can be lifted.

**Balancing the load**

An unbalanced load is likely to drop or damage the lifting equipment. Position the hook, slings, and harnesses so that the pulling force of the product lies on the center of gravity of the load. Also make sure that the load is balanced. When you begin to lift a load, check that it is properly balanced before lifting it high off the ground. If the load is not balanced, lower the load down and adjust the lifting point.

**Lifting centrally balanced loads**

The center of gravity is usually in line with the center of the load. As long as the contents of the container cannot move around, the balance of the load stays the same.

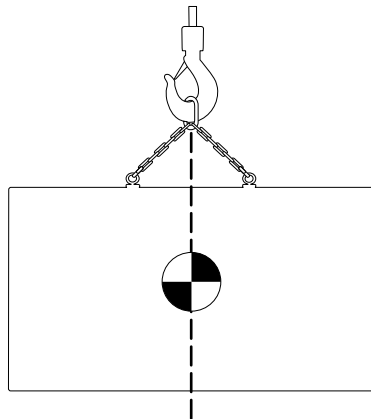

**Lifting off-center-balanced loads**

The center of gravity of an off-center-balanced load is usually towards the heavier end of the load. As long as the contents of the container cannot move around, the balance of the load stays the same.

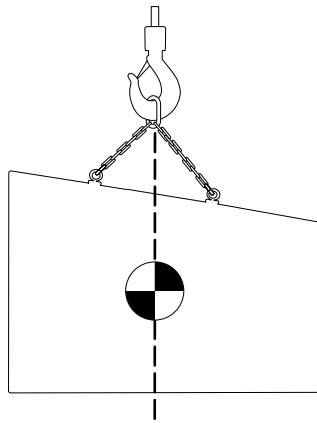

### WARNING! UNSTABLE LOAD HAZARD

Trying to balance an unbalanced load with your hands could cause death or serious injury.



Never try to balance an unbalanced load with your hands. Lower the load and adjust the lifting point.

### Shock loading

The hoist and accessories are designed to take up the weight of loads gradually and steadily. They are not designed to withstand sudden increases or decreases in the apparent weight of the load. Shock loading can occur in any situation where the load on the hoist suddenly increases or decreases.

The following list gives some examples on how shock loading can occur:

- Change in the load balance can suddenly pull on the chain.

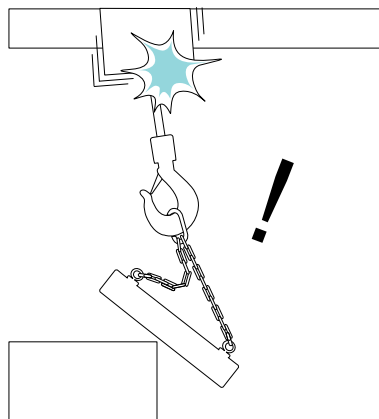

- If the load is unstable, it can exert a sudden force on the chain. Fasten the contents of the packing cases securely, so that they cannot move around during lifting.

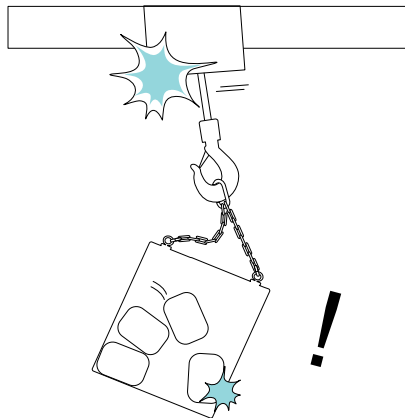

- Sudden loss of the load can cause the trolley or hoist to jump.

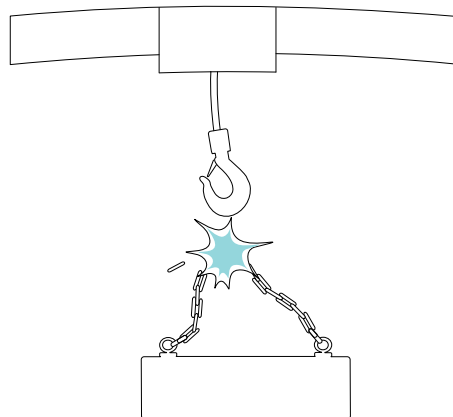

### OVERLOAD HAZARD

#### NOTICE

Shock loading could damage the product or the load.

Avoid shock loading the product.

### WARNING! MACHINE MALFUNCTION HAZARD



Any usage of defective equipment could cause serious injury, death, or damage to the equipment.

After a shock load, authorized service personnel or an experienced service technician who is authorized by the manufacturer must check the equipment and make sure that it is safe to use. Do not use the equipment before it has been checked and declared as safe to use.

### Attaching the load

The load is attached to the product with some kind of non-fixed load-lifting attachment. The most common non-fixed load-lifting attachments are chains, wire rope slings, and lifting belts. The operator must select a lifting device that is designed for the product to be transported.

#### NOTE

***Always follow the instructions provided by the lifting device manufacturer when using non-fixed load-lifting attachments. Never use the chains of the product as a sling to attach to the load.***

## Handling the load

- To avoid damaging the hook, position the lifting device only on the load bearing surface of the hook. In this way, the lifting device is positioned on the lowest point of the hook.

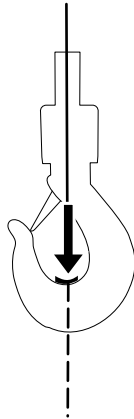

- Ensure that the hook safety latches are closed. Check that the safety latch is not subjected to any force by the load.

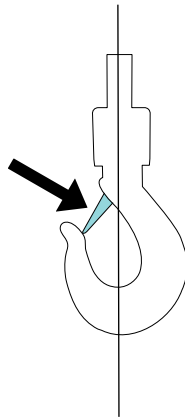

- Weight of the load must be centered on the center line of the hook forging so that the load does not bend the hook shank. Do not try to lift anything with the tip of the hook.

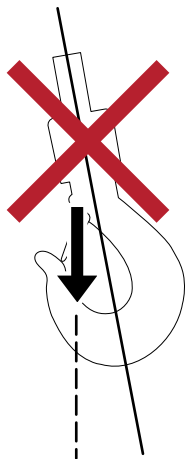

- Check that the load is balanced and safely fastened at the lifting points. The load must not be able to slide, slip, or detach itself when suspended.

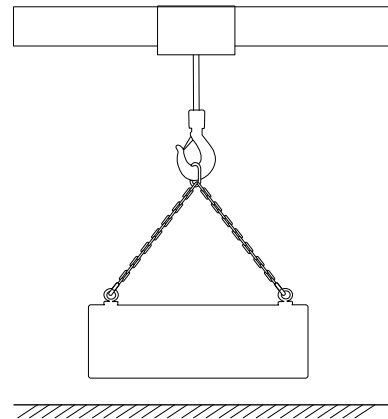
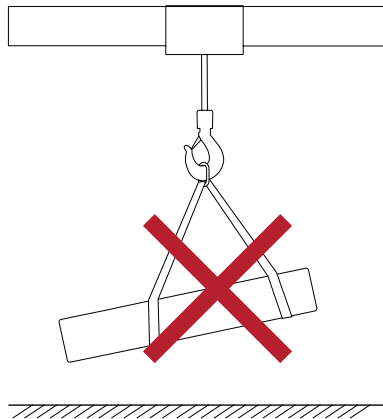

- Chain hoist must be positioned directly above (perpendicular to) the load so that there are no side-pulling forces.

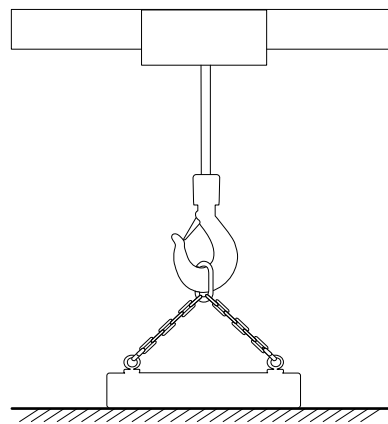
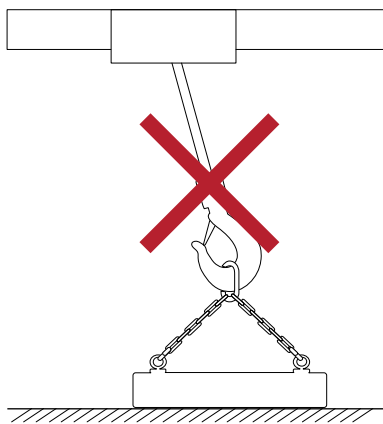

- Do not drag the load along the ground.

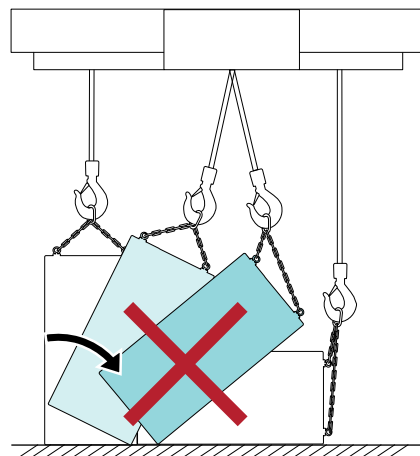
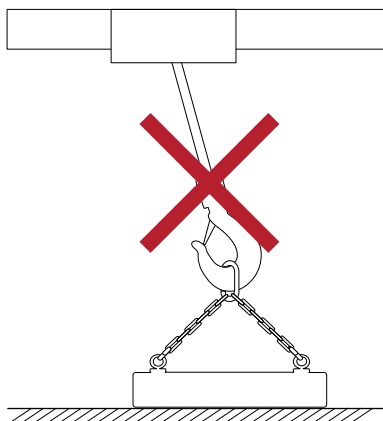



- Observe the load always while it is in motion to ensure that it does not collide with anything or fall from the lifting device.

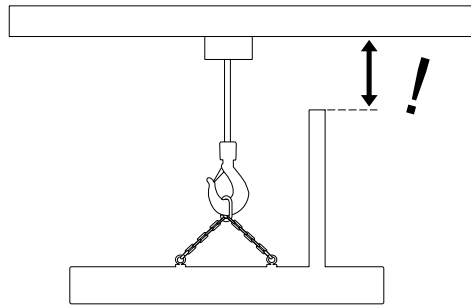

- 
- Do not drag loads or pull loads from the side.
  - Do not twist the load chains.
  - Do not swing the load intentionally.
  - Do not add any load to a hook that is already loaded.
  - Do not always drive the hook up to the highest or down to the lowest position. It is not recommended to use the mechanical limit switches as operational end stops. Using the mechanical limit switches as operational end stops can cause damages and lead to dangerous situations or accidents.
  - Do not drive the hook up to the upper limit and leave it at that position for a longer time. Leaving the hook at the upper limit damages the rubber part that activates the mechanical upper and lower limit switches.

## Lifting the load



### WARNING! MOVING LOAD HAZARD

Operating the product when people are underneath or near the load could cause serious injury or death.

When operating the product, make sure that there are no people who are situated underneath or near the load.



Keep yourself and bystanders away from the danger zone during lifting.

Never place a load over people.



### WARNING! ENTANGLEMENT HAZARD

There is a risk of catching or trapping your hands in the hook block or hoist. Catching or trapping your hands in the hook block or hoist could cause serious injury or death.



Never touch the chains or slings during the lifting.

1. Ensure that everything is ready for lifting. Do not move the load before ensuring that it is properly attached to the lifting device.

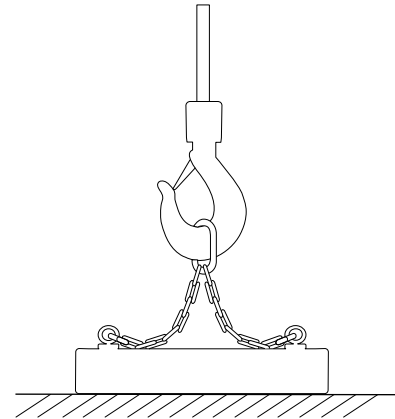
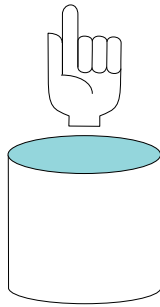

2. If the hoist has an alarm horn, press the alarm horn push button to warn people nearby that a load is about to be moved.

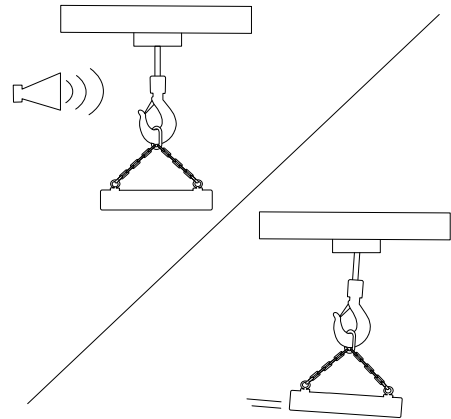
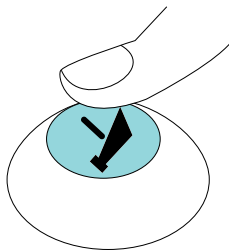

3. Press the push button UP gently to take up the slack from the chains or sling slowly before lifting the load from the ground.

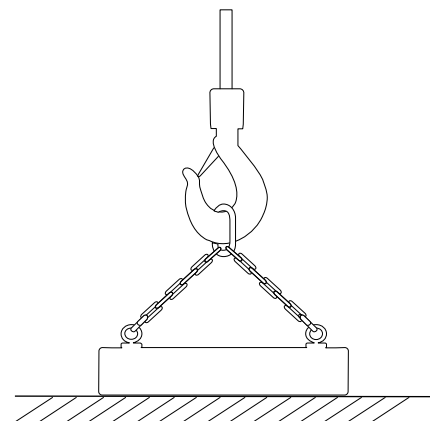
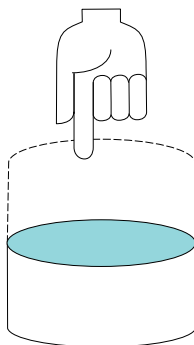

4. Continue to press the push button UP until the load is barely clear of the ground.

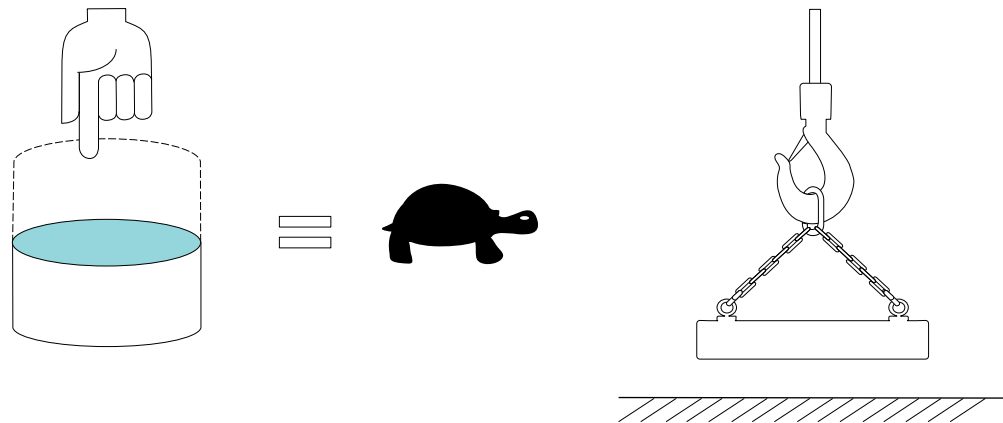

5. Press the UP push button to lift the load at high speed.

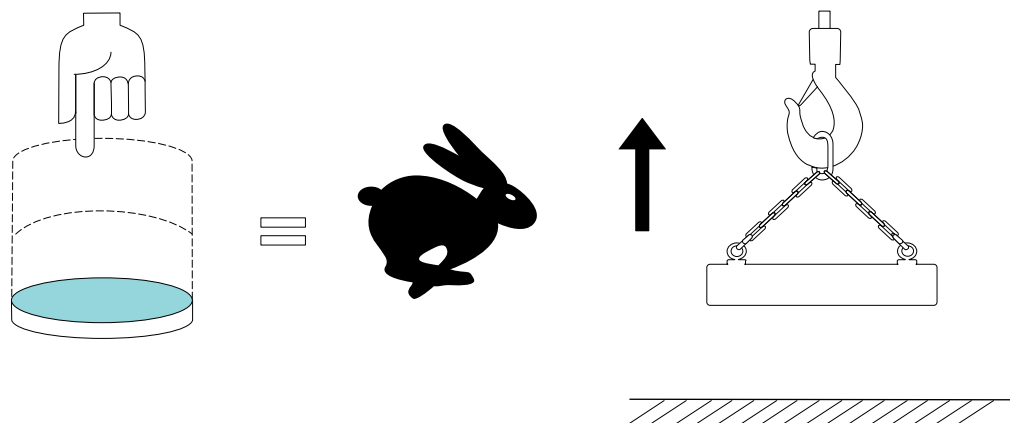

6. Release the UP push button gently when the load is at the desired height. Do not raise the load higher than is necessary to avoid colliding with objects.

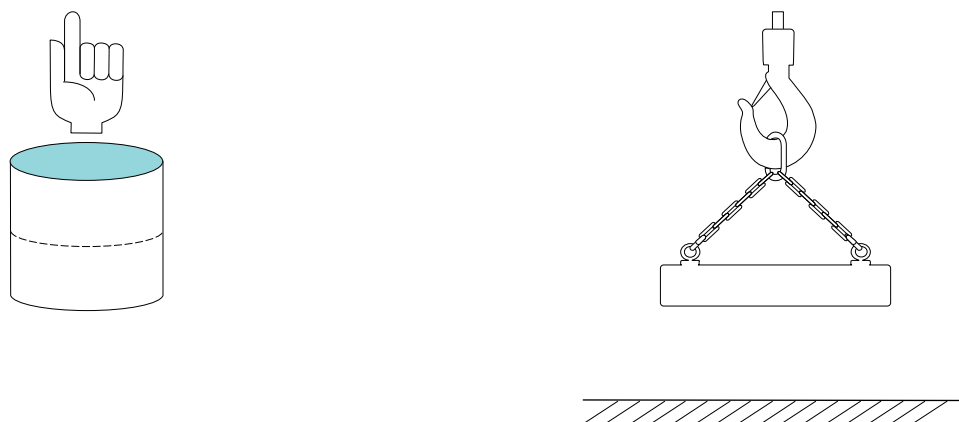

## Lowering the load



**WARNING! MOVING LOAD HAZARD**

Operating the product when people are underneath or near the load could cause serious injury or death.

When operating the product, make sure that there are no people who are situated underneath or near the load.

Keep yourself and bystanders away from the danger zone during lifting.

Never place a load over people.



1. Ensure that the landing area is clear of people and obstacles. Do not move the load before ensuring that it is properly attached to the lifting device.

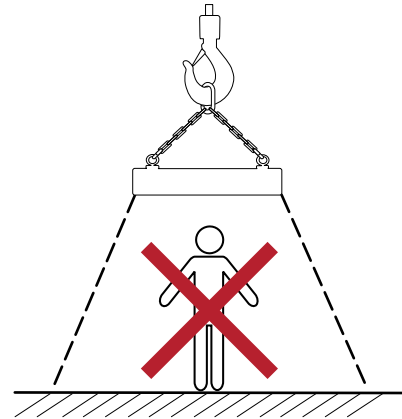
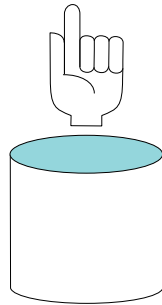

2. If the hoist has an alarm horn, press the alarm horn push button to warn people nearby that a load is about to be moved.

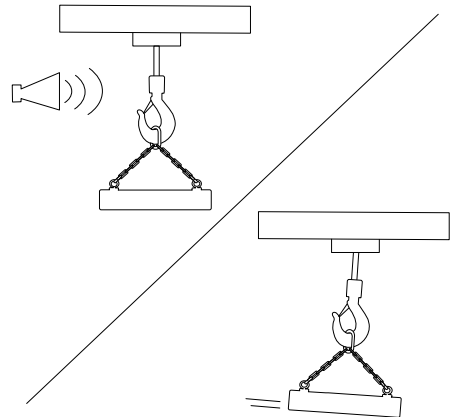
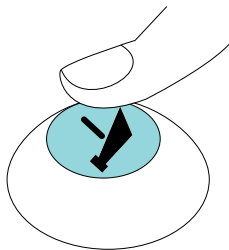

- Press the DOWN push button to lower the load.

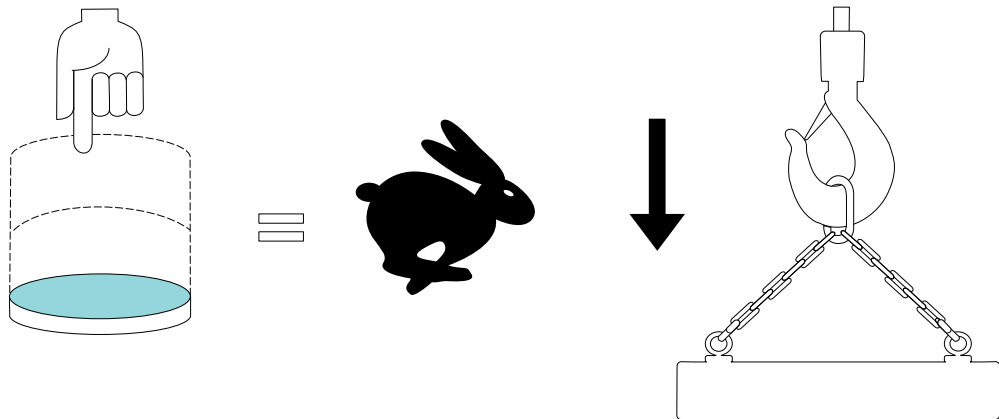

- Decrease the lowering speed by gradually releasing the DOWN push button when the load approaches the ground.

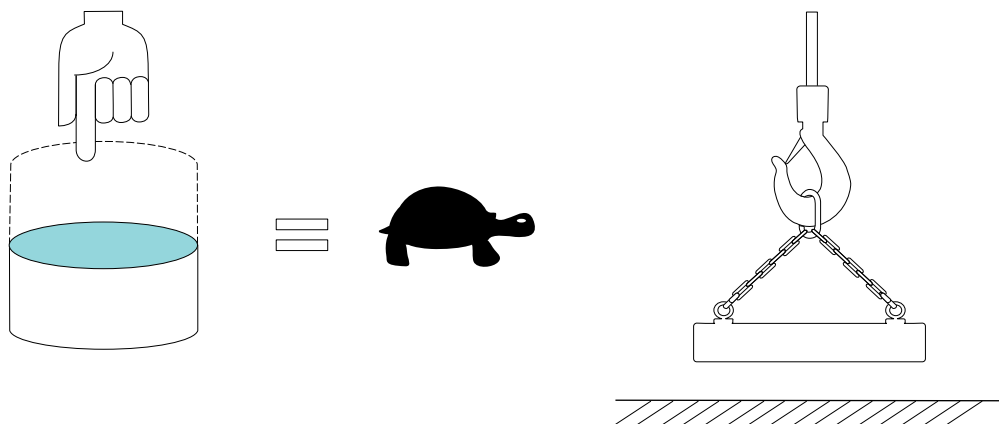

- Fully release the DOWN push button when there is slack in the lifting device but before the hook or lifting device impacts the load.

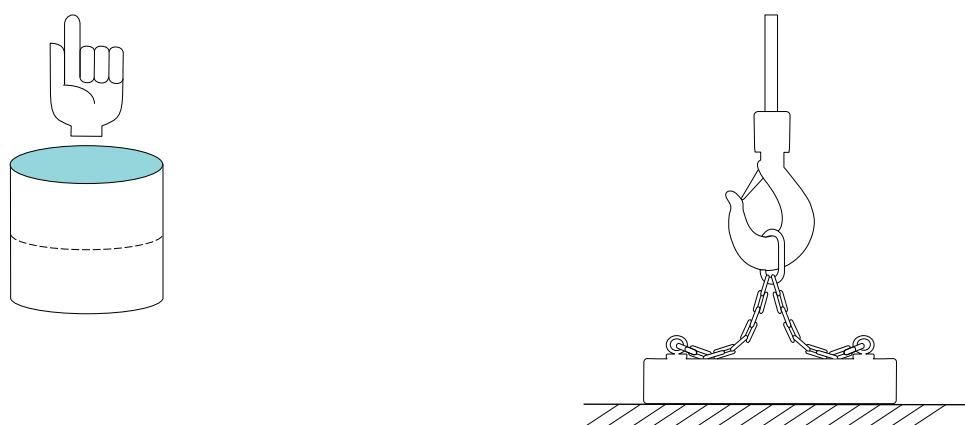

## Detaching the load

Remove the load from the hook by hand.

Never try to use crane motions to remove the load from the hook. The safety latch on the hook should prevent the load from being detached of the hook unintentionally.

## 6.5.2 Slipping clutch operation

The chain hoist is equipped with a slipping clutch that activates when an overload occurs. The brake activates then automatically, and the power to the motor is turned off.

After the slipping clutch is activated, only the lowering motion is possible. Therefore, it is not possible to lift an overload from the ground. If a load is already suspended from the hook, you can deposit it safely by pressing the lowering button on the controller. When you have completed the lowering of the load, also the lifting motion is possible again. If the slipping clutch activates already at the rated capacity of the hoist, the friction force must be measured and readjusted it if needed. A qualified service technician must do the measurement and possible readjustment of the friction force.



## 6.5.3 Hoisting limit switch operation

When the mechanical limit switch is activated, it is only possible to move the hook in the opposite direction. The limit stops at both ends of the chain limit the lifting height. The brake activates automatically, and the power to the motor is turned off. Elastic buffers on the stop limits activate the contact points and stop the hook motion.

## 6.6 Shutting down the equipment



The following checks must be done after every working shift to ensure that the hoist is in a safe condition.

1. Ensure that there is no load hanging from the hook.
2. Stop the hook in a position where it does not present a hazard to people or traffic. Preferably leave the hook at above-head height. However, do not stop the hook at the upper safety limit.
3. Engage the emergency stop button.
4. Turn off the power to the chain hoist.
5. Check the product for any visible damage.
6. Report all observed defects and abnormalities in the product or in its operation to your supervisor. Report the defects or abnormalities also to the next operator of the product.

 <b>WARNING</b>	
	<p><b>MACHINE MALFUNCTION HAZARD</b></p> <p><b>Operating a product that is in a dangerous condition could cause serious injury or death.</b></p> <p><b>Always remove the product immediately from service, if it is in a dangerous condition.</b></p>

## 7 MAINTENANCE

### 7.1 Safety during maintenance

 <b>WARNING</b>	
 	<p><b>IGNORING INSTRUCTIONS HAZARD</b></p> <p>Failure to follow the given instructions could cause serious injury or death. Read the general safety instructions at the beginning of these instructions and in this chapter.</p> <p>Special safety information is provided in the component-specific instructions.</p>

The safety information that is provided here is of general nature. The maintenance tasks include more detailed safety information. Observe all safety information. Following the safety instructions helps preventing hazards to the life and health of people and damage to the product and the environment. Always observe local safety rules and regulations.

- Wear approved personal protective equipment that is suited to the maintenance task. Do not wear loose clothing, a neck tie, or open shoes. Tie back long hair. For more information, see chapter Personal protective equipment.
- Follow the fall protection procedures.
- Do not store any flammable materials (for instance, oil drums) on the product. Follow the appropriate fire prevention and protection measures.
- Beware of hot components. Some components, such as motors, can become hot during use. Check that components are cool before working on them.
- Maintain a safety distance to all hazardous zones, especially when testing live components and with protective covers removed.
- Dismantling a component against these instructions or beyond the extent that is specified in these instructions could cause machine malfunction. Any dismantling of the assemblies over and beyond the specified limits is forbidden. Refrain from any actions that could affect the safety or integrity of the component.
- If you detect any critical defects during maintenance, make sure that the product is not operated until the defect has been rectified.

### 7.2 Maintenance preparations

The owner is responsible for organizing proper regular inspections and maintenance of the product. Regular inspections and maintenance ensure long-term safety, reliability, durability, operability, and warranty of the product. The owner must keep a record (log book) of all maintenance activities and usage related to the product.

The replacement parts and materials must meet the specifications that are defined by the manufacturer of the product. The owner must ensure that the specifications are met.

	<p><b>WARNING! MACHINE MALFUNCTION HAZARD</b></p> <p>Failure to maintain the product regularly and properly, or using a defective product could lead to serious injury, death, or damage to the product.</p> <p>Maintain the product regularly and according to the instructions provided by the manufacturer.</p> <p>Do not allow the product to be used if it is not in proper condition.</p>
---	---

**WARNING! MACHINE MALFUNCTION HAZARD**

Unauthorized changes or modifications to the product could lead to serious injury, death, or damage to the product. Unauthorized changes or modifications could also invalidate the guarantee of the product. The manufacturer takes no responsibility for accidents that are caused by unauthorized modifications to the product.

Only modify the product with the permission of the manufacturer. Any modifications to the product or its performance require a written approval by the manufacturer.

**NOTE**

*Only use genuine spare parts, materials, and lubricants that are approved by the manufacturer or representative of the manufacturer. The owner of the product must ensure that the replacement parts and materials meet these specifications. For more information, see the spare part manual of the product.*

**NOTE**

*Before carrying out any maintenance tasks, familiarize yourself with the chapter Safety during maintenance.*

**7.2.1 Service personnel**

Only authorized and approved service personnel may perform the detailed examinations that are necessary for the regular scheduled maintenance inspections. Approved service personnel include also experienced service technicians who are authorized by the manufacturer or a representative of the manufacturer. The scheduled maintenance inspections must be performed in accordance with the inspection and maintenance plan. The manufacturer of the product provides the inspection and maintenance plan for the product. The original manufacturer of the product or a representative of the manufacturer has authorized and approved service personnel to maintain the products.

The owner or operator of the product must perform the daily checks and, if necessary, the daily lubrication. Approved service personnel that are authorized by the owner may also lubricate the product at the necessary intervals.

**NOTE**

*Mechanical maintenance work requires special skills and tools to ensure safe and reliable operation of the product. Only authorized and approved service personnel may carry out the maintenance work. Approved service personnel include also experienced service technicians who are authorized by the manufacturer or a representative of the manufacturer.*

**7.2.2 Preservation of protection class**

The product has as a standard feature the protection class IP66. Preserving the IP rating of the product requires special attention and procedures in all maintenance tasks where the covers of the chain hoist are opened.

**NOTE**

*Every time that you reassemble the covers of the chain hoist, inspect the housing seals for any damage before the installation. If needed, replace the covers to preserve the protection class.*

**7.3 Maintenance schedule****7.3.1 Design working period (DWP)**

The anticipated hoisting machinery lifetime or design working period (DWP) is based on the planned use of the hoisting machinery and on the actual hardware that is supplied. The manufacturer agrees with the customer on the design working period of the hoisting machinery at the time of the purchase.

The total lifetime of a hoisting machinery consists of one or more design working periods. Each DWP lasts typically for around ten years, when the equipment is used according to the designed usage. It is possible that different hoisting machineries that belong to the same crane have a



different DWP. For example, the main hoisting machinery and the auxiliary hoisting machinery can have a different design working period. The DWP is the period in which the equipment can be operated safely, as long as the use and maintenance of the equipment has been in line with the original expectations.

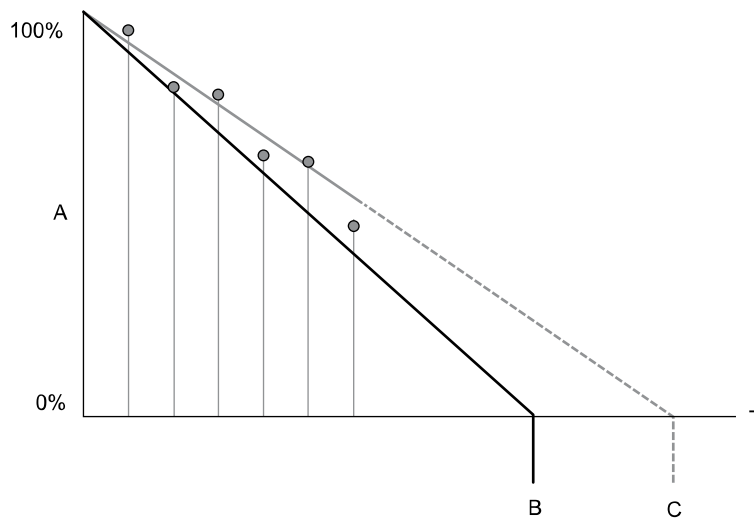

- A: Design working period (DWP)
- B: Predicted general overhaul (PGO)
- C: Actual general overhaul (AGO)
- T: Time

In practice, the lifetime of the equipment can vary as a result of changes in the environment and use of the equipment. For safety reasons and according to the ISO 12482-1, it is important to check the equipment duty class periodically and the operating conditions regularly for any changes. The checks must be done by authorized service personnel, who can revise the remaining DWP % upwards or downwards accordingly. This action ensures that the equipment is kept operating for as long as it is safely possible before a general overhaul (GO) must be conducted.

The hoist service organization assesses the hoisting machinery DWP, but the following table briefly describes how it is done.

Record type	Method
Hour counter and log book	The remaining DWP % must be calculated in accordance with the ISO 12482-1 standard. For instructions, see chapter DWP calculation.
Log book	
No log book	

### Design working period (DWP) calculation

The end of the design working period (DWP) must be calculated in accordance with the ISO 12482-1 standard during each recurring inspection and service. If the component does not have a condition monitoring unit, use the following method to calculate the remaining DWP %.

**NOTE**

***The values used in each DWP calculation, and the result and the date, must be carefully recorded in the log book. Each DWP calculation requires the use of figures that are recorded during previous calculations.***

**Step 1: Calculate the motor operating hours (running hours) for each inspection interval,  $T_i$**

- Check the following values for this inspection interval:
  - J = Number of working days during the inspection interval [days]
  - H = Average lifting height [m]
  - N = Average number of work cycles per hour [cycles/h]
  - T = Average daily operating time [h]
  - V = Maximum hoisting speed [m/min] (as shown on the data plate)
- Use the following formula to calculate  $T_i$ , the motor operating hours (total lifting time) for each inspection interval:

$$T_i = \frac{2 * H * N * T * J}{V * 60}$$

**For example, if you use:**

J = 180 [days], H = 5 [m], N = 20 [cycles/h], T = 12 [h], V = 5 [m/min]

$$T_i = \frac{2 * 5 * 20 * 12 * 180}{5 * 60} = 1440$$

**Step 2: Calculate the actual load spectrum factor for each inspection interval,  $K_{mi}$**

- Divide the total lifting time in proportion to the actual load spectrum during the inspection interval.  
For example, if the product has lifted full loads (100%) for half of the time and no load (0%) for half of the time, then record 50 for each of these two in the column Lifting time % of the following table.

Load %	Lifting time %		Factor $k^3$		Load spectrum factor
100%		*	1	=	
80%		*	0.51	=	
60%		*	0.22	=	
40%		*	0.06	=	
20%		*	0.01	=	
0%		*	0	=	
Total:	100%		Sum:		
Divide by 100:					Sum/100 =
Load spectrum factor, $K_{mi}$ :					

- Check that the sum of the figures in the column Lifting time % is 100%.
- Multiply each entry in the column Lifting time % by the multiplier in the “Factor  $k^3$ ” column. Write the results in the column Load spectrum factor column.
- Add up the numbers in the column Load spectrum factor column and record the result of this sum.
- Divide the sum of the column Load spectrum factor column by 100 to get the  $K_{mi}$ .

**For example, if you use:**

100% load for 10% of the time, 40% load for 30% of the time, and 20% load for 60% of the time:

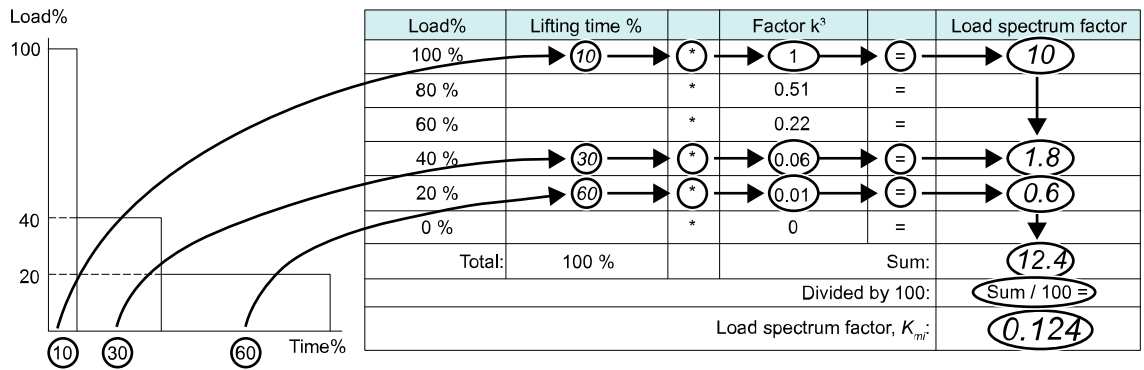

### Step 3: Calculate the partial duration of service, $S_i$

- Use  $T_i$  and  $K_{mi}$  in the following formula to calculate  $S_i$  [hours]:  

$$S_i = X * K_{mi} * T_i$$
- Select the value of X from the following table:

Record type	Value of X
Hour counter and log book	1.2
With log book	1.4
No hour counter, log book, or CMS	1.5

#### For example, if you use:

$X = 1.2$ ,  $K_{mi} = 0.124$  and  $T_i = 1440$ :

$$S_i = 1.2 * 0.124 * 1440 = 214.272$$

### Step 4: Calculate the actual duration of service, S

- Add together each of the  $S_i$  partial duration of service values that are gathered from this and previous inspection intervals since the start of the design working period.
- The earlier S values ( $S_1...S_i$ ) can be read from the log book.  
 For example:  $S = S_1 + S_2 + ... + S_i$

#### For example, if you use:

$S_1 = 215.468$ ,  $S_2 = 210.26$ ,  $S_3 (S_i) = 214.272$ :

$$S = 215.468 + 210.26 + 214.272 = 640$$

### Step 5: Calculate the DWP% and remaining service life

1. Check the hoist duty group which can be found on the hoist data plate.
2. In the appropriate column of the following table, find the number closest to S. The two final columns on the same row tell you the remaining DWP% and the estimated remaining service life.

Hoist duty group						DWP %	Years <sup>1)</sup>
M3 (1Bm)	M4 (1Am)	M5 (2m)	M6 (3m)	M7 (4m)	M8 (5m)		
Actual duration of service, S [h]							
0	0	0	0	0	0	100%	10
40	80	160	320	630	1250	90%	9
80	160	320	640	1260	2500	80%	8
120	240	480	960	1890	3750	70%	7
160	320	640	1280	2520	5000	60%	6
200	400	800	1600	3150	3250	50%	5
240	480	960	1920	3790	7500	40%	4
280	560	1120	2240	4410	8750	30%	3
320	640	1280	2560	5040	10000	20%	2
360	720	1440	2880	5670	11250	10%	1
400	800	1600	3200	6300	12500	0%	0

<sup>1)</sup> Estimated remaining service life in years

3. Record the value of the DWP% in the log book.

**For example, if you use:**

S = 640, Hoist duty group = M5 (2m) then the DWP% = 60%:

Hoist operating group marked on hoist's rating plate						DWP %	t*
M3 (1Bm)	M4 (1Am)	M5 (2m)	M6 (3m)	M7 (4m)	M8 (5m)		
Actual duration of service, S [h]							
0	0	0	0	0	0	100 %	10
40	80	160	320	630	1250	90 %	9
80	160	320	640	1260	2500	80 %	8
120	240	480	960	1890	3750	70 %	7
160	320	640	1280	2520	5000	60 %	6
200	400	800	1600	3150	3250	50 %	5
240	480	960	1920	3790	7500	40 %	4
280	560	1120	2240	4410	8750	30 %	3
320	640	1280	2560	5040	10000	20 %	2
360	720	1440	2880	5670	11250	10 %	1
400	800	1600	3200	6300	12500	0 %	0

When the DWP% reaches zero, a general overhaul (GO) must be conducted. For more information, see chapter General overhaul.

### 7.3.2 General overhaul

In the general overhaul (GO) service, the product is assigned with a new, runtime-based design working period (DWP), provided that it is safe to continue the operation. The runtime-based DWP means the lifetime of the interchangeable rotating components of the hoist, for example, the hoisting gear and the hoisting motor. For instructions on how to perform the DWP calculation, see chapter DWP calculation.

#### WARNING! MACHINE MALFUNCTION HAZARD



Using a defective chain hoist could cause serious injury, death, or damage to the equipment.

When the DWP of the chain hoist has decreased to zero or is counting in the negative, do not use the chain hoist until after a GO service has been conducted. Alternatively, replace the chain hoist with a new one.

#### WARNING! MACHINE MALFUNCTION HAZARD



When performing the general overhaul, do not change the construction of the chain hoist or repair the supporting structures without permission of the manufacturer. Unauthorized changes or modifications to the product could cause serious injury, death, or damage to the equipment.



If there are any deformations, cracks or corrosion in the supporting structures of the hoist, replace or repair the parts according to the instructions that given by the manufacturer.

Only authorized service personnel or an experienced service technician who is authorized by the manufacturer or the manufacturer's representative may conduct a general overhaul service.

The data and the information about conditions based on which the general overhaul should be performed can be provided for a chain hoist by one or more of the following means:

- A time counter keeping track of the hoist operational hours (runtime)
- Manual bookkeeping/diary/logbook about the use and the operating conditions of the hoist.

#### NOTE

***The same hoisting machinery can undergo no more than two general overhauls before it must be replaced completely.***

The chain hoists are designed for a period of use of at least 10 years until the first general overhaul is carried out. This is based on the condition that the specified group of mechanisms is not exceeded by the actual duration of service. When the actual duration of service has reached the theoretical duration of service valid for the group of mechanisms, further operation of the chain hoist is only permissible after a general overhaul.

The theoretical duration of service  $D$  (hours at full load  $h$ ) depends on the group of mechanisms classification of the chain hoist. The actual duration of service is to be determined annually in accordance with FEM 9.755. During the annual inspection by our after-sales service, you may have the actual service life determined.

Upon expiration of 90% of the theoretical duration of service – if the chain hoists are correctly classified after 8 to 10 years – the owner must arrange for a general overhaul to be carried out. A general overhaul must be carried out no later than when the end of the theoretical duration of service is reached.

During the general overhaul the following parts must be replaced in addition to the checks and work specified in the inspection and maintenance schedule:

- Gearbox frame, sealing, bearing, gears, and oil or grease
- Hook block, coupling, connection pins
- Brake

The small parts (such as screws and washers) to be replaced during maintenance and assembly work are not listed separately. The general overhaul carried out by the manufacturer or an authorized specialist company fulfills the condition for continued operation of the chain hoist.

Thus the relevant accident prevention regulations and the BGV D8 (VBG 8) are complied with.

Further utilization is approved when an expert engineer has entered the conditions for further utilization into the test and inspection booklet. Completion of the general overhaul must be confirmed in the test and inspection booklet and a further period of utilization in accordance with FEM 9.755 must be entered.

Action	Chapter(s)	Before 1st run	Before each work shift	Annual inspection
Check the function of the emergency stop device.	Checking the operation with the emergency stop button pushed down		X	
Check the direction of movements.	Testing the hoist without load	X		
Check the chain lubrication.	Lubrication	X	X	
Check the function of the limit switches.	Testing the hoist without load	X		1)
Check the control cable and controller housing for damage.	Checking the hoist before every working shift		X	X
Check the operation of the brake.	Testing the hoist without load	X		X
Check the hook and the hook safety latch.	Checking the hoist before every working shift, Measuring wear on the hook		X	
1) To be checked on a monthly level.				

### 7.3.3 Daily inspections

The daily inspection items are listed in the chapter Checks before operating. Usually, these checks are performed by the operator.

### 7.3.4 Monthly inspections

The monthly inspection items include the same check-ups as the daily inspections (see chapter Checks before operating). The monthly inspections also include the following inspections:

## General monthly inspections

Component	Objective
Chain	Check the overall condition and the lubrication of the chain.
Limit switch activator	Check the condition of the limit switch activator. Check the function of the upper and lower mechanical limit switches by raising and lowering the hook.
Slipping clutch	Check the operation of the slipping clutch. Use the ChainQ tool or see the instructions in chapter Adjusting the slipping clutch.

### 7.3.5 Quarterly inspections

The quarterly inspection items include the same check-ups as the daily (see chapter Checks before operating) and the monthly inspections. The quarterly inspections also include the following inspections:

#### General quarterly inspections

Component	Objective
Suspension part	Check the suspension part for nicks, gouges, deformations, or wear.

### 7.3.6 Annual inspections

The annual inspection items include the same checks as the daily (see chapter Checks before operating), monthly, and quarterly inspections. The annual inspections also include the following inspections:

#### General annual inspections

Component	Objective	Reference
Hoist	Check the condition of the fixing of the covers.	
Chain	Measure the wear of the chain (if the hoist is in continuous use, check the wear of the chain more frequently).	For instructions on how to measure the chain wear, see chapter Inspecting the wear of the chain.
Rubber parts	Check the condition of the rubber pad in the idle end of the chain (inside the chain bag).	
Stickers and markings	Check the condition and readability of the warning and other stickers.	
Instructions and log books	Check the readability of the instructions. Check the validity of the log book.	

#### Annual inspections of the limiting devices

Component	Objective
Buffers	Check the condition of the buffers and the end stops of the buffers.
Slipping clutch	Check the operation of the slipping clutch. Use the ChainQ tool or see the instructions in chapter Adjusting the slipping clutch.

## Annual inspections of the electrical components

Component	Objective
Main isolation switch	Check the condition and operation of the main isolation switch.
Wiring	Check the condition of the wiring and the connections.
Contactors	Check the condition and operation of the contactors.
Fuses	Check the condition of the fuses. For instructions, see chapter Replacing the control voltage fuse.

## Annual inspections of the motors and brakes

Component	Objective	Reference
Motors	Check the operation of the motors.	
Brakes	Check the operation and wearing of the brake.	For instructions on how to check the brake wear, see chapter Checking the brake lining.

## Annual inspections of the mechanical components

Component	Objective
Chain sprocket	Check the condition of the chain sprocket. With two-fall hoists, also check the return sprocket.
Chain guide	Check the condition of the chain guide.
Chain bucket	Check the fixing and the condition of the chain bucket.
Bearings	Check the greasing of the return sprocket bearing.
Load carrying structure	Check the condition of the bolted joints and load carrying structures. Check the condition and mounting of the securing components.

## Annual inspections of the control devices

Component	Objective
Pendant controller	Check the condition and functionality of push buttons and switches.

**NOTE** *The product may have options which also require inspection. Make sure that all components are inspected.*

### 7.3.7 Log book

The log book is supplied in the interest of accident prevention. It is a part of the product, and must be kept up-to-date and together with the equipment at all times. Do not remove or discard any parts of the log book. The log book records the complete maintenance history of the product. The log book must be handed over to the new owner, if the ownership of the product changes.

**NOTE** *The owner (who has the primary responsibility), operators, and service personnel must ensure that the log book is kept up-to-date.*

**The log book consists of the following items:**



1. Product reference data - details of the product, its ownership, and persons who are qualified to work with it.
2. Faults noticed in daily inspections, together with corrective actions.
3. Records of service inspections and lubrication.
4. Records of repairs.
5. Records of condition monitoring unit or hour counter.
6. Calculations of design working period and remaining lifetime.

According to the ISO 12482-1, it is mandatory to keep record of the usage of the equipment. Records must be kept so that it is possible to compare the usage of the equipment with the design principles and design limits from the supplier. Records must also be kept of all maintenance work, inspections, unusual occurrences (for example, unexpected loads from operational error, extreme climate conditions), breakdowns, repair work, and modifications.

Where complete records are not available, the product must be inspected in accordance with Annex A of ISO 9927-1. Any required actions that may result from that inspection must be carried out before the equipment is used any further.

## 7.4 Maintaining the hoist

### 7.4.1 Checking the suspension

The suspension type of the chain hoist is either a rotating suspension hook or a suspension bracket. The rotating suspension hook is the standard suspension type, the suspension bracket is available as an option. Inspect the condition of the suspension regularly.

#### Inspect the condition of the suspension:

- Check the suspension for possible damage or cracks.
- Measure wear on the suspension according to the wear criteria in the following table.

If cracks are detected or the wear of the dimension 'W' of the suspension exceeds the allowed minimum values, replace the suspension immediately.

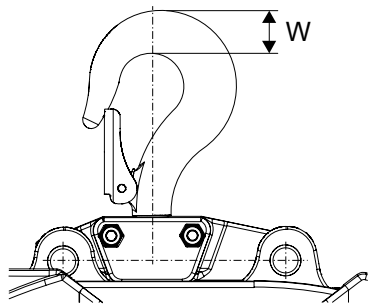

Figure 16. Measuring wear on the rotating suspension hook

Table 2. Wear dimensions of the rotating suspension hook

Hook type	Dimensions [mm]			
	Nominal DIM W	Nominal DIM X	Min. DIM W	Max. DIM X
<b>RSN020-T</b>	22	27	20.9	29.7
<b>RSN05-V</b>	31	34	29.5	37.4

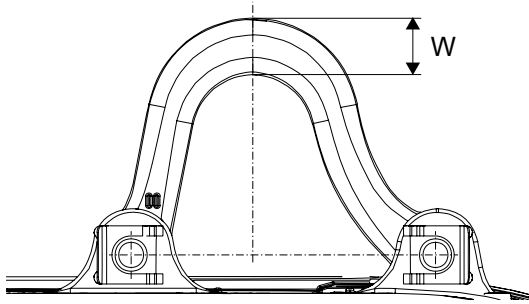

Figure 17. Measuring wear on the suspension bracket (option)

Table 3. Wear dimensions of the suspension bracket (option)

Frame size	Bracket type			
	Short [DIM mm]		Long [DIM mm]	
	Nominal DIM	Min. DIM W	Nominal DIM	Min. DIM W
05	21.50	19.00	21.50	19.00
10	-	-	26.00	23.00

### 7.4.2 Checking the brake lining

1. If a load is attached to the hook, remove the load.
2. Disconnect the chain hoist from the main power supply network.
3. Remove the end cover on the brake side.  
For more information, see chapter Removing and installing the hoist covers.
4. Check the main brake.  
To check the brake lining of the main brake, locate the brake check hole in the brake assembly.

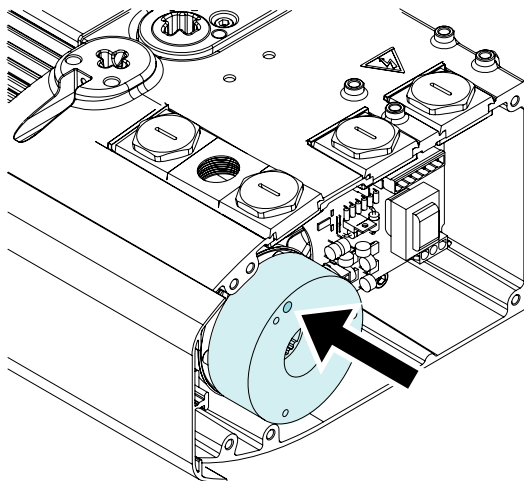

5. Measure the depth of the gap in the brake check hole with a caliper.
6. Compare the measured brake wear value with the maximum allowed value for brake wear.  
You can find the maximum value for the brake wear in the brake data sticker on the brake.

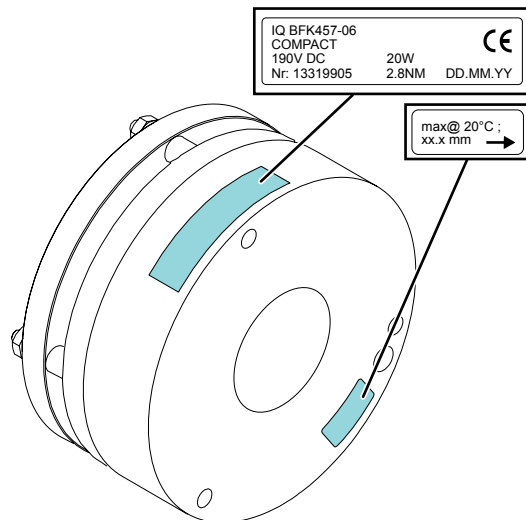

**NOTE**

**The brake wear value varies according to the brake manufacturer and brake series. For each brake type, the maximum value for the wear is indicated on the brake data sticker on the brake.**

**Do not exceed the maximum value for the brake wear.**

7. If the brake has worn more than the maximum allowed criteria, replace the brake.
8. Check the secondary brake.  
If the hoist has a double brake, the brake assembly includes also a secondary brake. The secondary brake (2) is the brake that is on the top in the double brake assembly. The secondary brake is a holding brake that works as a back-up brake for the main brake (1). The secondary brake is the functional brake only, if the main brake is damaged and not able to hold the load.

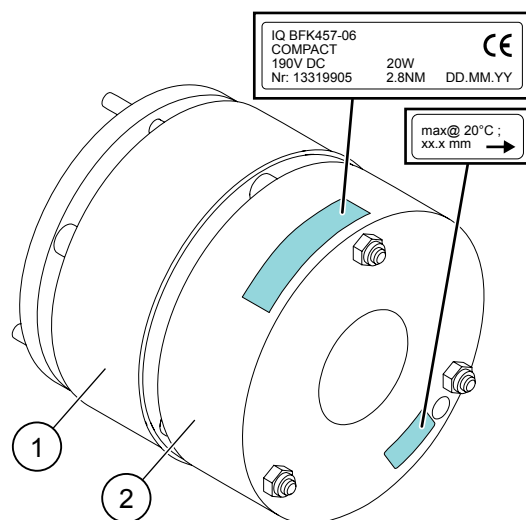

**NOTE**

**If the main brake operates normally, you do not need to check the wear on the secondary brake.**

### 7.4.3 Replacing the single brake

1. If a load is attached to the hook, remove it.
2. Disconnect the chain hoist from the main power supply network.
3. Remove the end cover on the brake side.

For more information, see chapter Removing and installing the hoist covers.

4. Check that the brake data of the replacement brake matches with the data of the original brake.  
You can find the brake data in the sticker that is attached to the brake.

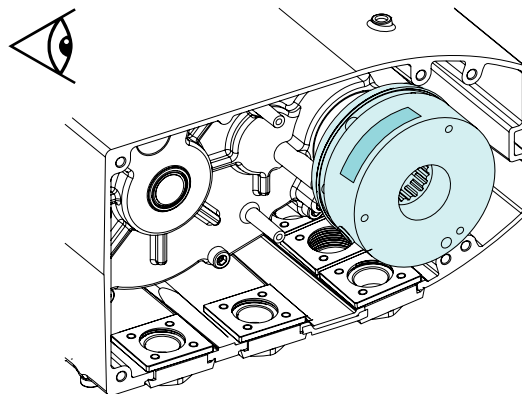

5. Unplug the brake cable (1) from the control board.

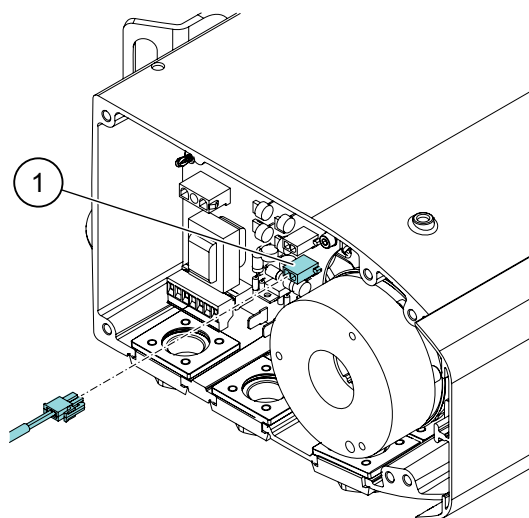

6. Remove the three screws that hold the brake in place.

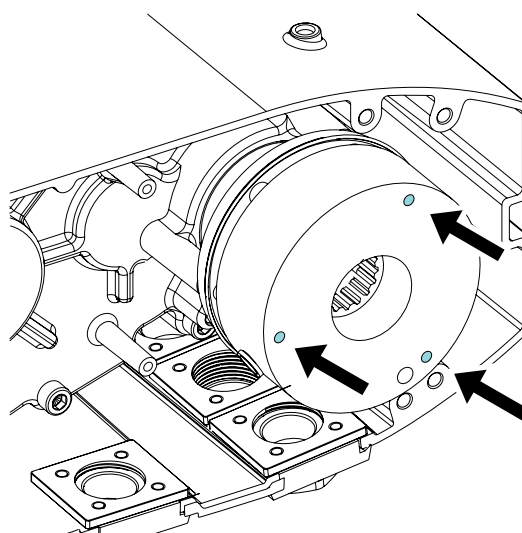

- Remove the brake carefully.

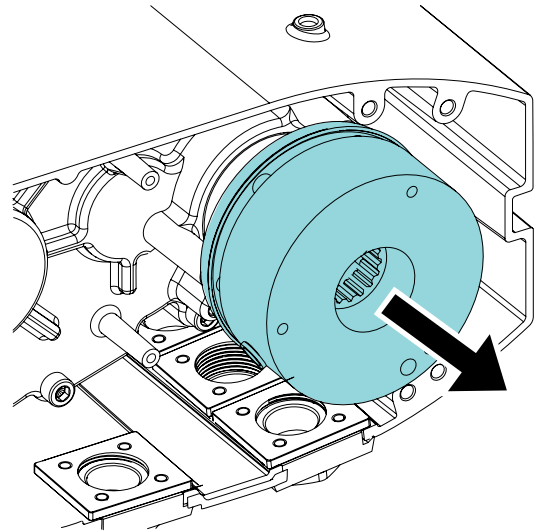

- Install the new brake on the shaft.  
Secure the fixation with the three screws.

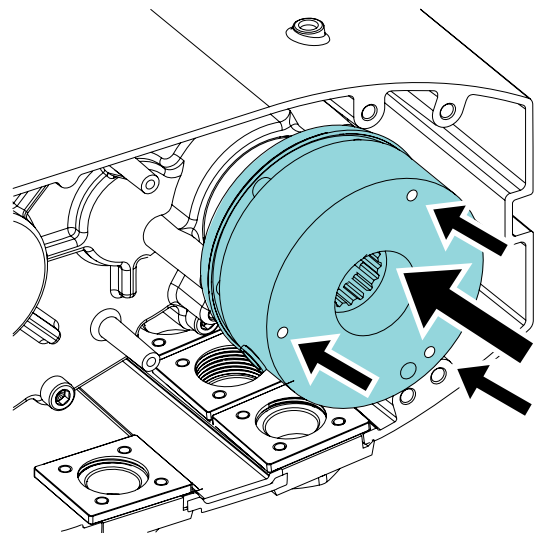

- Plug in the brake cable (1).

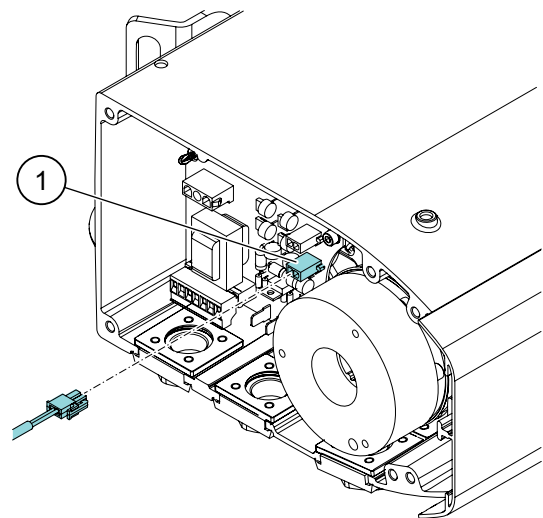

- Install the end cover on the brake side.  
For more information, see chapter Removing and installing the hoist covers.
- Tighten the screws of the end cover to the correct tightening torque.

For more information, see chapter Tightening torques for the chain hoist.

12. Turn on the power to the chain hoist.
13. Check that the brake works normally.
  1. First test the brake without any load.
  2. Then test the brake with a dynamic test load of 110% (EUR) or 125% (US) of the rated capacity. Size of the dynamic test load depends on the country regulations.
  3. In the European countries, test the brake also with a static test load of 125% of the rated capacity.

### 7.4.4 Replacing the single brake

1. If a load is attached to the hook, remove it.
2. Disconnect the chain hoist from the main power supply network.
3. Remove the end cover on the motor side.  
For more information, see chapter Removing and installing the hoist covers.
4. Pull out the control board.

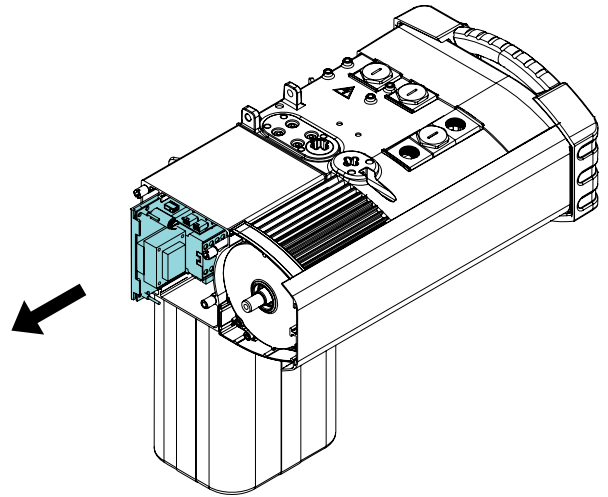

5. When the control board is a few centimeters out, unplug the brake cable (1) from the control board.

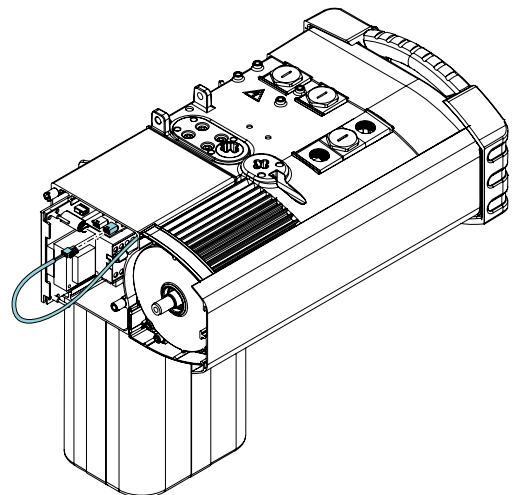

6. Remove the end cover on the brake side.  
For more information, see chapter Removing and installing the hoist covers.

- Pull the brake cable carefully out on the brake side.

**NOTE**

*The brake cable is led through the hoist frame from the brake side to the motor side. Pay attention to how the brake cable is led through the hoist frame. When you have installed the new brake, you must lead the brake cable again from the brake side back to the motor side.*

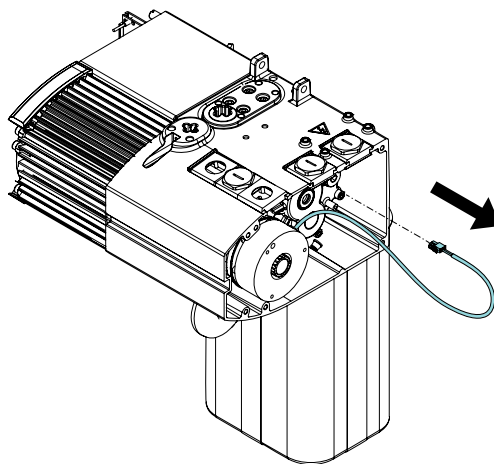

- Check that the brake data of the replacement brake matches with the data of the original brake. You can find the brake data in the sticker that is attached to the brake.

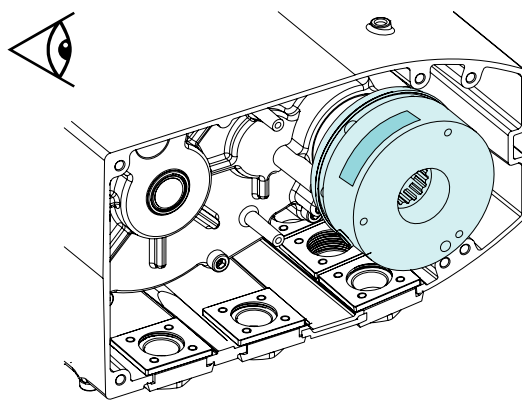

- Remove the three screws that hold the brake in place.

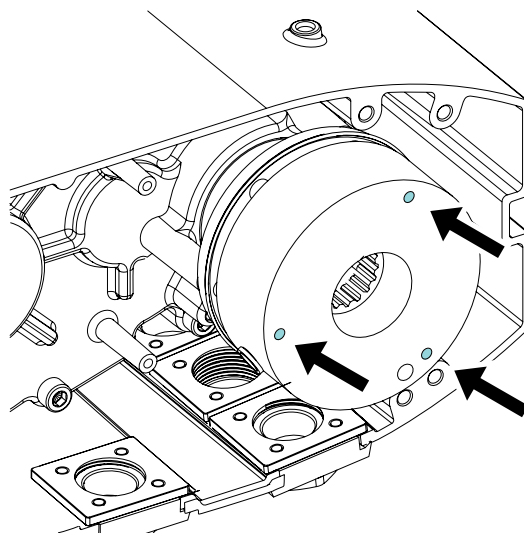

10. Remove the brake carefully.

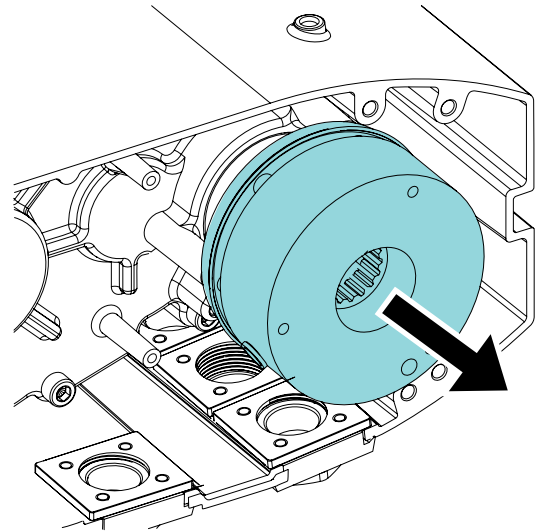

11. Install the new brake on the shaft.  
Secure the fixation with the three screws.

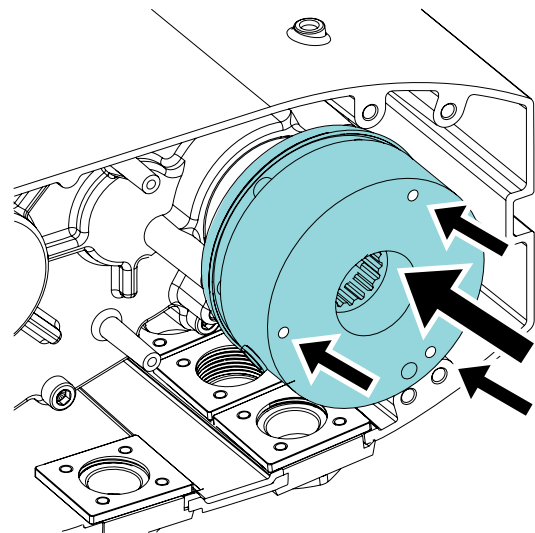

12. Lead the brake cable through the hoist frame.  
Pull the brake cable carefully out on the motor side.

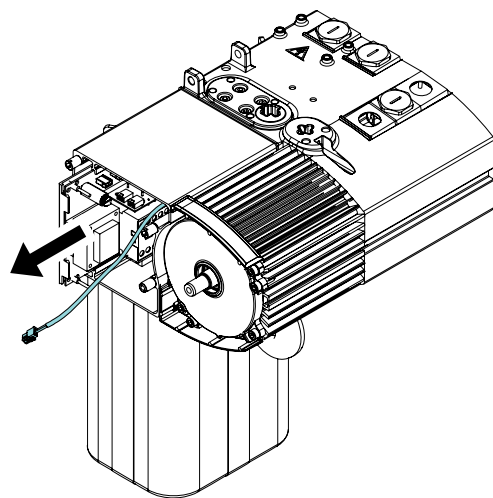



13. Plug in the brake cable (1).

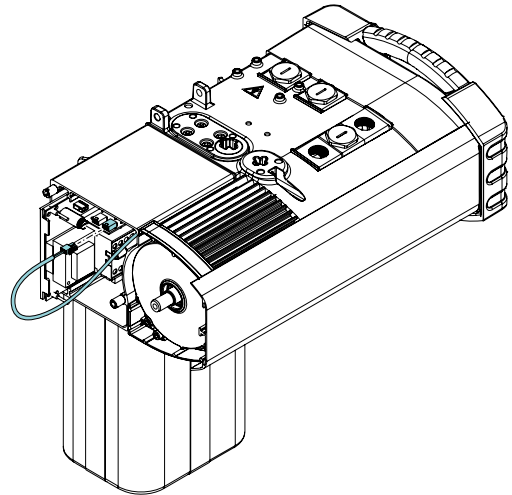

14. Push in the control board.
15. Install the end cover on both the motor side and brake side.  
For more information, see chapter Removing and installing the hoist covers.
16. Tighten the screws of the end covers to the correct tightening torque.  
For more information, see chapter Tightening torques for the chain hoist.
17. Turn on the power to the chain hoist.
18. Check that the brake works normally.
  1. First test the brake without any load.
  2. Then test the brake with a dynamic test load of 110% (EUR) or 125% (US) of the rated capacity. Size of the dynamic test load depends on the country regulations.
  3. In the European countries, test the brake also with a static test load of 125% of the rated capacity.

## 7.4.5 Replacing the double brake

1. If a load is attached to the hook, remove it.
2. Disconnect the hoist from the main power supply network.
3. Remove the end cover on the brake side.  
For more information, see chapter Removing and installing the hoist covers.
4. Check that the brake data of the replacement brake matches with the data of the original brake.  
You can find the brake data in the sticker that is attached to the brake.

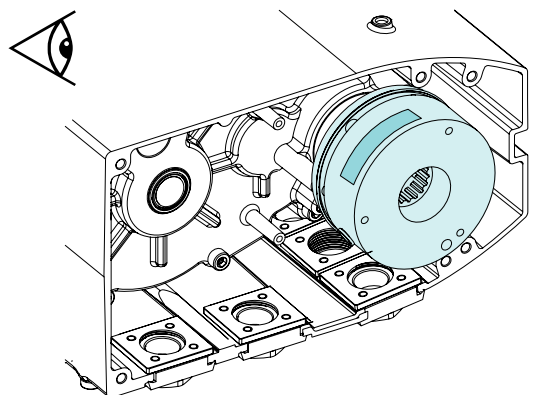

- Unplug the brake cables (1) and (2) from the control board.

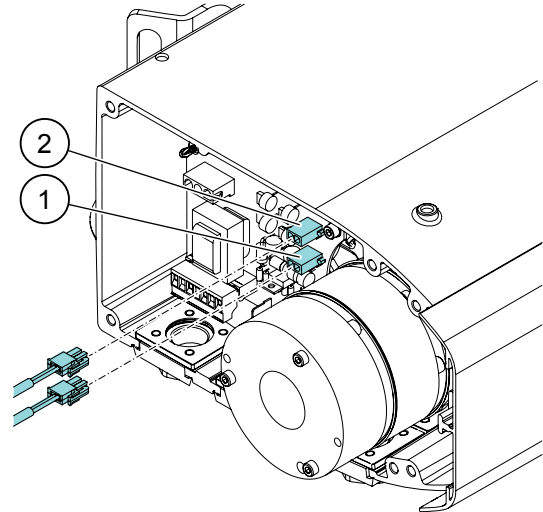

1. Main brake

2. Secondary brake

- Remove the three screws that hold the brake in place.

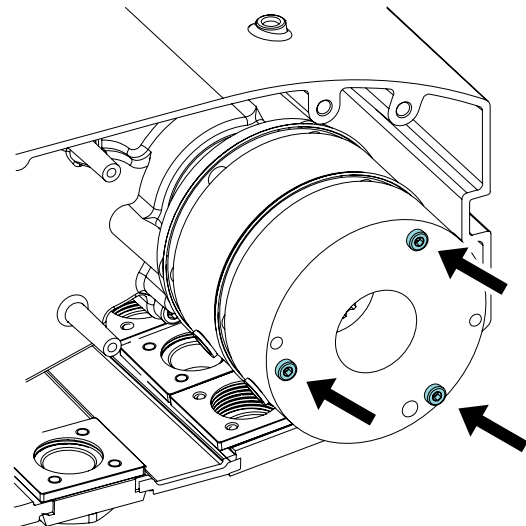

- Remove the brake carefully.

### NOTE

***Hold the complete double brake assembly with your hands so that the parts do not fall apart.***

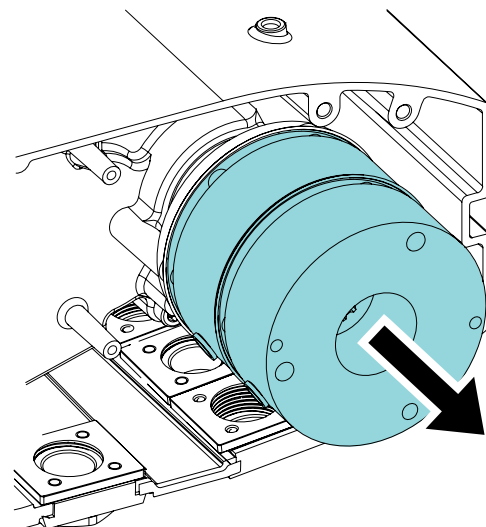

8. Assemble the new double brake.

**NOTE** *Pay attention to the orientation of the brake lining.*

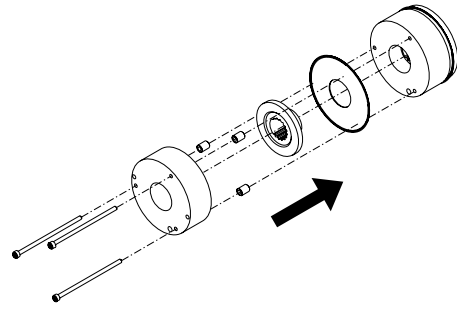

9. Install the new brake on the shaft.
  1. Secure the fixation with the three screws. Pre-tighten the screws by hand.
  2. Tighten the screws with a tool.
  3. If the brake has two more screws, remove the screws.

**NOTE** *There may be two extra screws on the brake. The screws are used during transportation to keep the brake components together. Remove these two screws when you have installed the new double brake.*

**NOTE** *The top brake is the main brake, and the bottom brake is the secondary brake.*

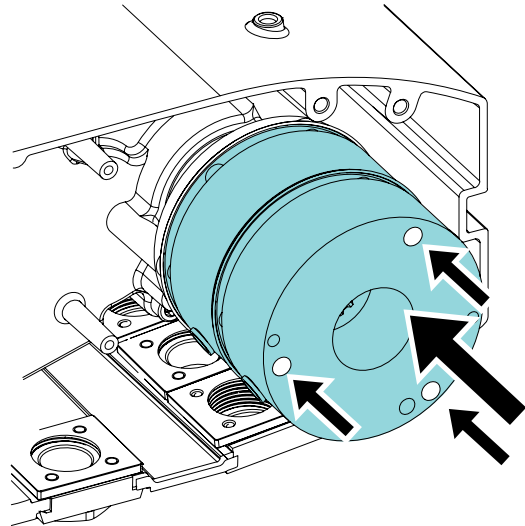

10. Plug in the brake cables (1) and (2).

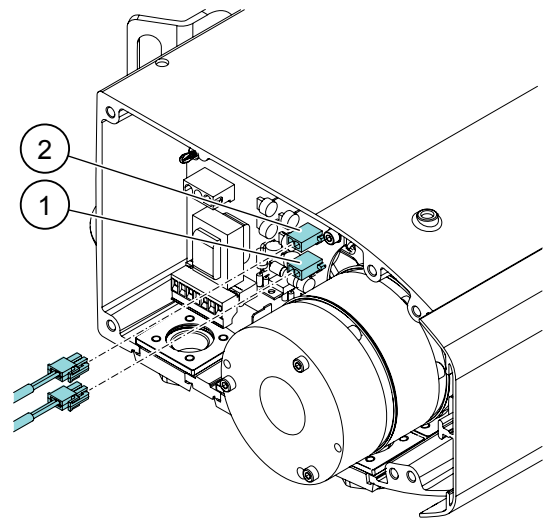

1. Main brake

2. Secondary brake

11. Install the end cover on the brake side.  
For more information, see chapter Removing and installing the hoist covers.
12. Tighten the screws of the end cover to the correct tightening torque.  
For more information, see chapter Tightening torques for the chain hoist.
13. Turn on the power to the hoist.
14. Check that the brake works normally.

1. First test the brake without any load.
2. Then test the brake with a dynamic test load of 110% (EUR) or 125% (US) of the rated capacity. Size of the dynamic test load depends on the country regulations.
3. In the European countries, test the brake also with a static test load of 125% of the rated capacity.

### 7.4.6 Replacing the double brake

1. If a load is attached to the hook, remove it.
2. Disconnect the chain hoist from the main power supply network.
3. Remove the end cover on the motor side.  
For more information, see chapter Removing and installing the hoist covers.
4. Pull out the control board.

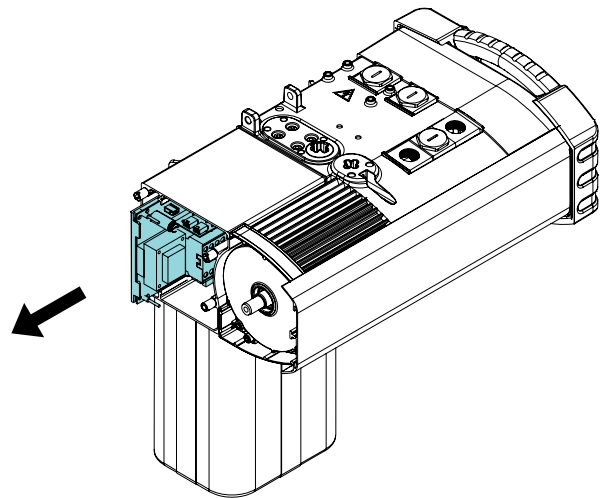

5. When the control board is a few centimeters out, unplug the brake cables (1) and (2) from the control board.

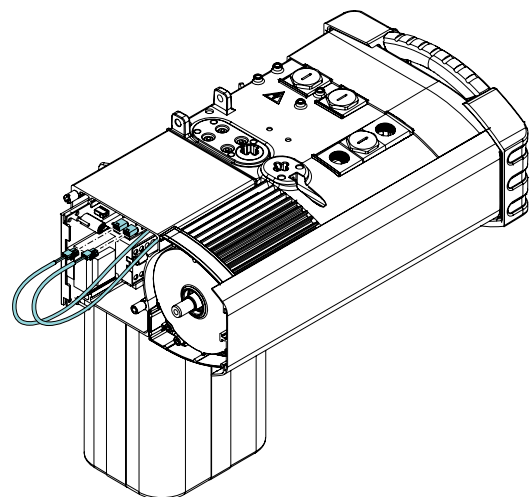

1. Main brake

2. Secondary brake

6. Remove the end cover on the brake side.  
For more information, see chapter Removing and installing the hoist covers.

- Pull the brake cables carefully out on the brake side.

**NOTE**

*The brake cables are led through the hoist frame from the brake side to the motor side. Pay attention to how the brake cables are led through the hoist frame. When you have installed the new brake, you must lead the brake cables again from the brake side back to the motor side.*

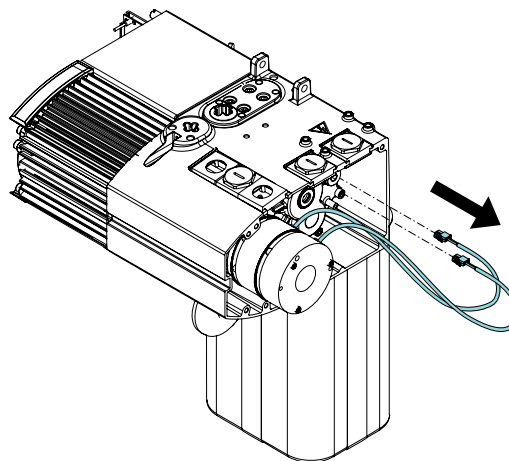

- Check that the brake data of the replacement brake matches with the data of the original brake. You can find the brake data in the sticker that is attached to the brake.

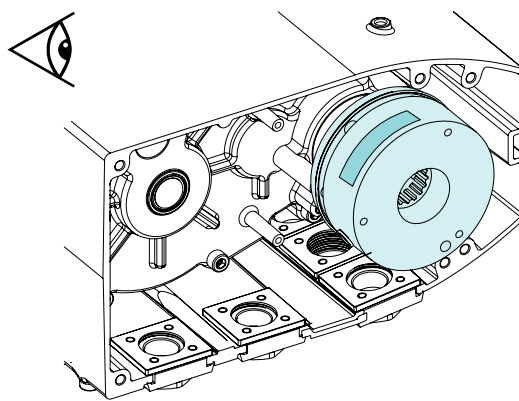

- Remove the three screws that hold the brake in place.

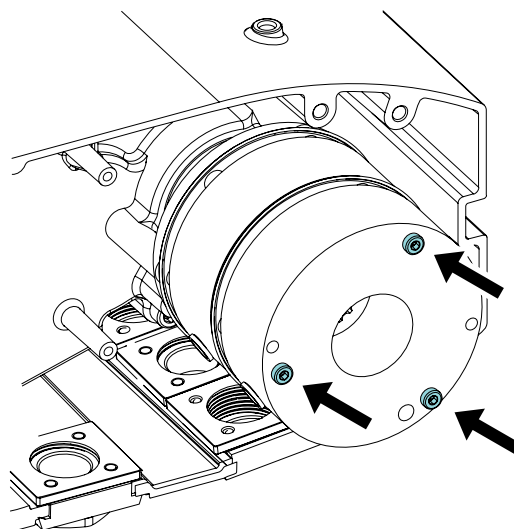

10. Remove the brake carefully.

**NOTE**

*Hold the complete double brake assembly with your hands so that the parts do not fall apart.*

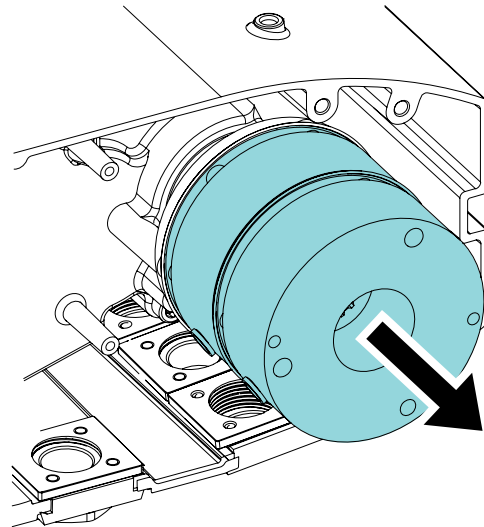

11. Assemble the new double brake.

**NOTE**

*Pay attention to the orientation of the brake lining.*

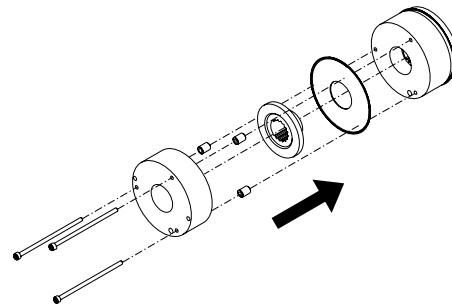

12. Install the new brake on the shaft.

1. Secure the fixation with the three screws. Pre-tighten the screws by hand.
2. Tighten the screws with a tool.
3. If the brake has two more screws, remove the screws.

**NOTE**

*There may be two extra screws on the brake. The screws are used during transportation to keep the brake components together. Remove these two screws when you have installed the new double brake.*

**NOTE**

*The top brake is the main brake, and the bottom brake is the secondary brake.*

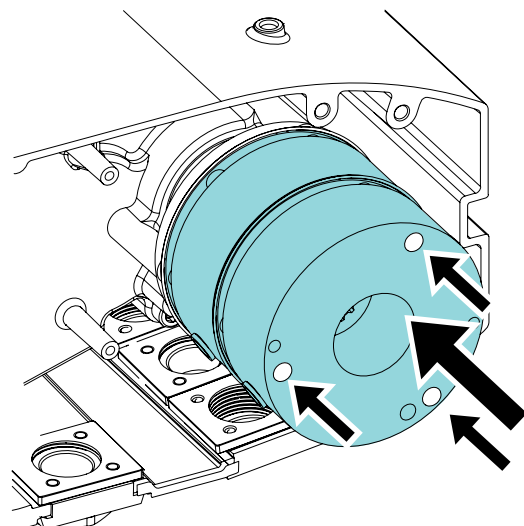

13. Lead the brake cables through the hoist frame. Pull the brake cables carefully out on the motor side.

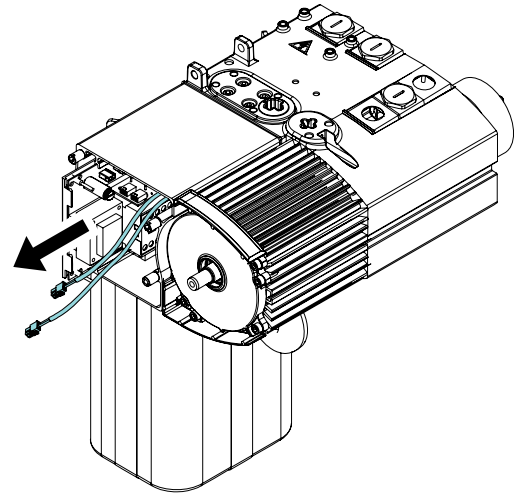

14. Plug in the brake cables (1) and (2).

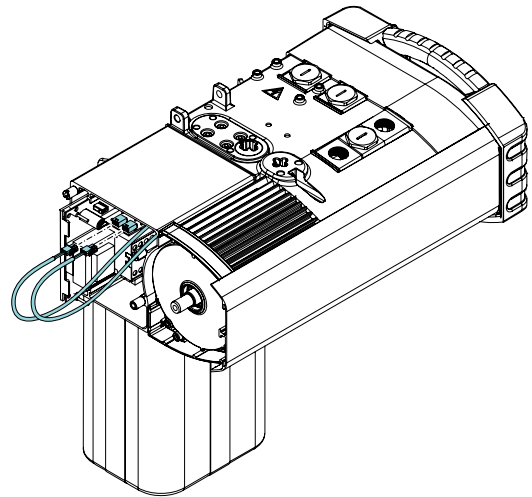



1. Main brake

2. Secondary brake



15. Push in the control board.
16. Install the end cover on both the motor side and brake side.  
For more information, see chapter Removing and installing the hoist covers.
17. Tighten the screws of the end covers to the correct tightening torque.  
For more information, see chapter Tightening torques for the chain hoist.
18. Turn on the power to the chain hoist.
19. Check that the brake works normally.
  1. First test the brake without any load.
  2. Then test the brake with a dynamic test load of 110% (EUR) or 125% (US) of the rated capacity. Size of the dynamic test load depends on the country regulations.
  3. In the European countries, test the brake also with a static test load of 125% of the rated capacity.

## 7.4.7 Adjusting the slipping clutch

### WARNING

 	<p><b>MOVING MACHINERY HAZARD</b></p> <p>When you adjust the slipping clutch, the motor must not run. Contact with the moving parts of the motor could lead to serious injury, death, or damage to the product.</p> <p>Always turn off the power to the chain hoist before starting to work with the clutch adjustment tools.</p>
--	---

### WARNING

 	<p><b>MOVING MACHINERY HAZARD</b></p> <p>When you adjust the slipping clutch, make sure that you do not touch any of the moving components. Touching the moving components during the adjustment of the slipping clutch could cause serious injury or death.</p> <p>Always turn off the power to the chain hoist before starting to adjust the slipping clutch.</p>
--	---

1. Attach a load of 125% of the rated capacity of the chain hoist to the hook.

#### NOTE

***Certain regulations, such as the European EN standard, require only a load of 110% of the rated capacity for the dynamic testing.***

2. Try to lift the load with slow and fast speed.
  - ▶ If the chain hoist cannot lift the load, remove the load. Turn off the power to the chain hoist. Proceed to step 3.
  - ▶ If the chain hoist is able to lift the load, proceed to phase 3 in step 5.
3. Remove the end cover on the brake side.  
For more information, see chapter Removing and installing the hoist covers.
4. Adjust the slipping clutch.  
To adjust the slipping clutch, turn the adjustment screw at the center of the brake. To increase the torque, turn the adjustment screw clockwise. To decrease the torque, turn the adjustment screw counter-clockwise.

#### NOTE

***Make sure that you do not over-tighten the adjustment screw. Over-tightening the adjustment screw can damage the springs of the slipping clutch.***



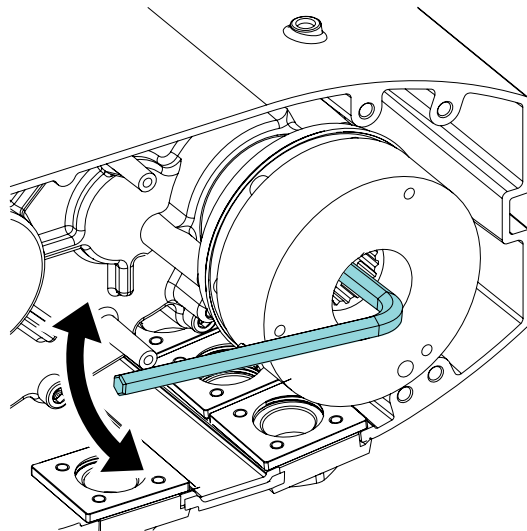

5. Test the slipping clutch.
  - 5.1 Turn on the power to the chain hoist.
  - 5.2 Attach the original test load to the hook.
  - 5.3 Check that the chain hoist is able to lift the load with both slow and fast speed.
  - 5.4 Attach a maximum load of 160% of the rated capacity of the chain hoist to the hook.
  - 5.5 Test with slow speed that the load remains on the floor.
    - ▶ If either one of the tests fails, modify the capacity of the chain hoist. Follow the instructions that are given in the step 4.
    - ▶ When both tests are successful, proceed to step 6.
6. Turn off the power to the chain hoist.
7. Install the end cover on the brake side.  
For more information, see chapter Removing and installing the hoist covers.
8. Tighten the screws of the end cover to the correct tightening torque.  
For more information, see chapter Tightening torques for the chain hoist.

## 7.4.8 Replacing the control voltage fuse

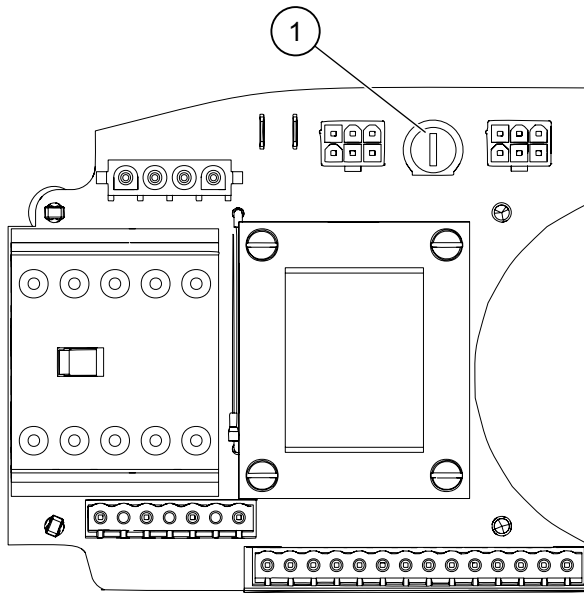

Figure 18. Power supply board with control voltage fuse

The control voltage fuse (1) is on the chain hoist power supply board, on the brake side of the chain hoist.

1. Disconnect the chain hoist from the main power supply network.
2. Remove the fuse gently from its holder.  
Make sure that you do not damage the other components.
3. Check the condition of the fuse.

### Glass fuse

- 3.1 Check the fuse for burn marks.  
If burn marks can be found, the fuse is blown. Replace the fuse.
- 3.2 Check the filament.  
If the filament is inconstant, the fuse is blown. Replace the fuse. If the filament is constant and there are no burn marks on the fuse, the fuse is in good condition.

### Ceramic fuse

If a ceramic fuse is used, use a continuity checker, a multimeter, or an ohmmeter to check the condition of the fuse.

- ▶ Continuity checker: Connect the leads to both ends of the fuse. If you cannot hear a beep, the fuse is blown.
  - ▶ Multimeter or ohmmeter: Connect the leads to both ends of the fuse. Set the meter at 1  $\Omega$ . If the meter shows a value that is close to 1  $\Omega$ , the fuse should be in good condition. If no value is shown, the fuse is blown. Replace the fuse.
4. If the fuse is blown, replace it with a new one.  
Check the correct rating for the new fuse from the blown fuse.
  5. Place the new fuse gently to the holder.
  6. Connect the chain hoist to the main power supply network.

## 7.5 Maintaining the chain drive

### 7.5.1 Removing the chain bucket

1. Open the screw-lock carabiners (3).

2. Remove the chain bucket (1) from the connection part (2).

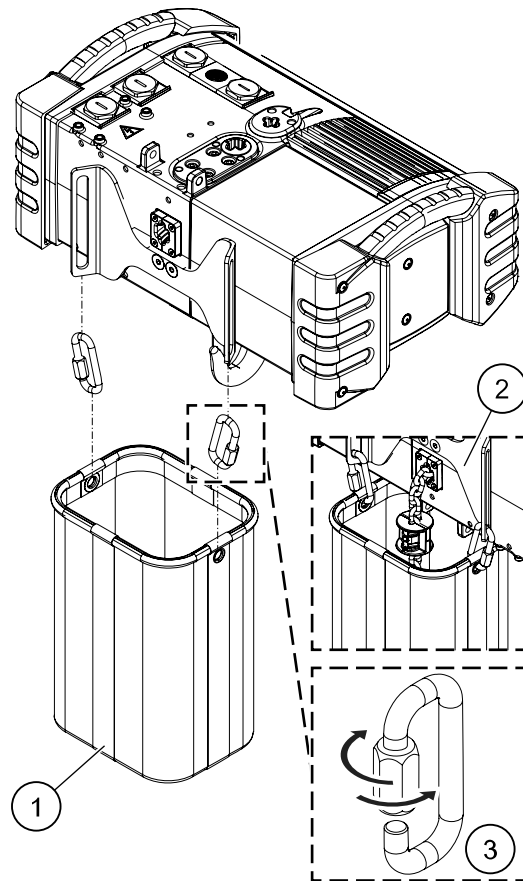

## 7.5.2 Inspecting the chain wear

### **WARNING**



#### **FALLING LOAD HAZARD**

Premature wear of the chain can lead to a load drop, which could cause serious injury, death, or damage to the equipment.

Special operating conditions or the design of the product may shorten the required maintenance and inspection intervals of the product. If, for example, the chain hoist always brakes heavily at the same position and with a heavy load, the wear on the chain links may increase. The increased wear occurs on the chain links that are in the area of the chain sprocket or return sprocket when the brake is applied.

Inspect the chain regularly for wear, rust, and corrosion. Check the chain links for excessive pitting, corrosion, nicking, gouging, twisting, or wear. If you detect increased wear or other damage on the chain or the chain links, replace the chain with a factory approved new chain.

1. Examine the chain visually for nicks, gouges, weld splatter, or corrosion. Check the chain for distorted links and slackened chain.

2. Check the bearing surfaces between the chain links for wear.

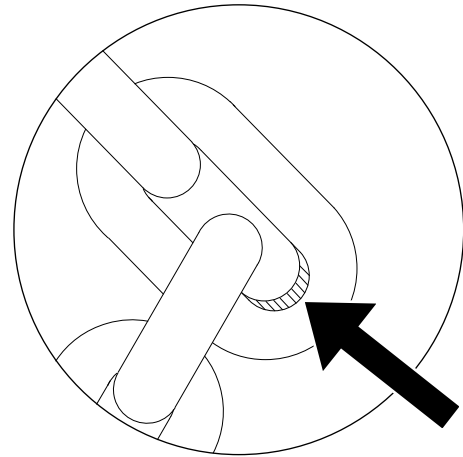

3. Measure the link thickness.  
Measure the link thickness dimension (d) at several points of the chain. Calculate the dimension (d<sub>m</sub>).

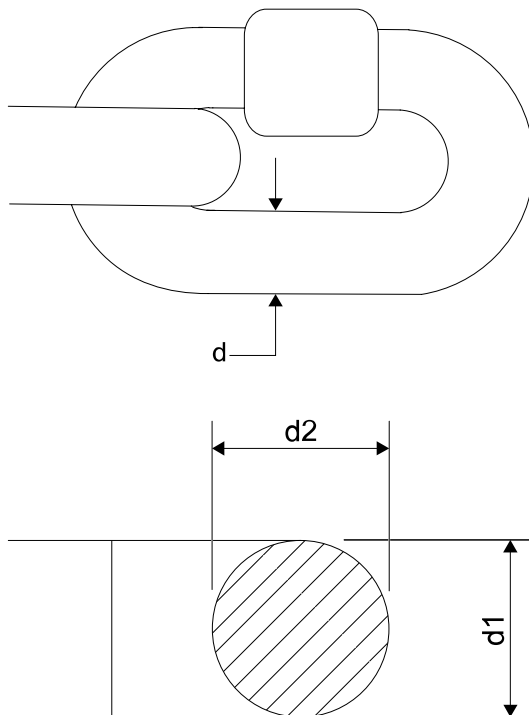

### Link thickness measurement criteria

d * t	Chain size		
	4.1 x 12.1	5.1 x 15.1	7.2 x 21.1
<b>d<sub>n</sub> [mm]</b>	4.1	5.1	7.2
<b>t [mm]</b>	12.8	15.9	22.4
<b>d<sub>m</sub> min [mm]</b>	3.8	4.8	6.7

<sup>1)</sup> d<sub>n</sub> = Nominal link thickness dimension.

d * t	Chain size		
	4.1 x 12.1	5.1 x 15.1	7.2 x 21.1
2) t = Overall length of 1 chain link, measured on the inside.			
3) $d_m = (d_1 + d_2) / 2$ .			

**NOTE**

*Use only a "knife-edge" caliper or a tool that is sold by the Crane Part Center for measuring the link thickness. Using the recommended tools helps you to make sure that you measure the full pitch length. Not measuring the the full pitch length can lead to a false reading result.*

4. Measure the elongation of the chain.  
Measure the pitch over 11 links (P) at different sections of the chain.

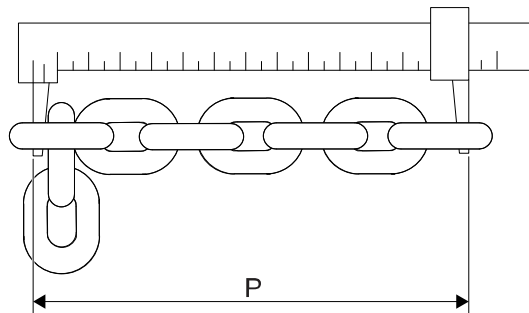

**NOTE** A 2% elongation according to ISO 7592.

**Chain elongation measurement criteria**

d * t	Chain size		
	4.1 x 12.1	5.1 x 15.1	7.2 x 21.1
<b>d<sub>n</sub> [mm]</b>	4.1	5.1	7.2
<b>P max [mm]</b>	144.7	180.3	253
1) d <sub>n</sub> = Nominal link thickness dimension.			
2) P = Pitch over 11 links.			

**NOTE**

*If the chain wear exceeds the allowed limits for the chain wear measurement, replace the chain immediately. Check also the wear on the chain guide and the chain sprocket. If necessary, replace the chain guide and chain sprocket.*

**NOTE**

*If any chain link is in some way defective, replace the chain.*

**NOTE**

*A chain cannot be determined as safe based only on the wear measurement and chain replacement criteria. Check the condition of the chain also visually. The visual checks may show that the chain is unsafe or must be replaced, even if the replacement is not necessary based on the chain elongation measurement criteria.*

**NOTE**

*A repetitive stop and start at the same point of the chain causes increased wear on the chain links 2-3 in the chain sprocket.*

### 7.5.3 Lubrication instructions for the chain

#### Initial lubrication of the chain

Lubricating the chain is part of the commissioning procedures of the chain hoist.

For cleaner installation routines, the chain hoist is delivered with an unlubricated chain. Even if the chain feels oily, it is not lubricated, but has only a corrosion protection. The initial lubrication of the chain is part of commissioning preparations of a new chain hoist. Information about the lubricants that are delivered with the chain hoist is in the chapter Lubricant information.

#### WARNING! EQUIPMENT FAILURE HAZARD



Failing to do the initial lubrication of the chain leads to premature wear of the chain and other components of the chain drive. Without the initial lubrication, the lifetime of the chain and the complete chain drive is reduced drastically. As a result, the chain can fail. The wearing starts immediately after taking the chain hoist into use.

**Lubricate the chain carefully before taking the chain hoist into use for the first time.**

#### Lubricating the chain

The target of the chain lubrication is to have enough lubricant between the chain links. The lubricant (grease or oil) must be applied on the contact surfaces between the chain links. Make sure that you add the new layer of lubrication always on a clean surface. Lubricate the chain without any load that is attached to the hook.

1. Drive the hook all the way down until the chain is out of the chain bag and the chain bag is empty.  
If a load is attached to the hook, remove the load.
2. Lubricate the chain.  
Start applying the lubricant on the chain from the top, close to the hoist. Then proceed from top to bottom of the chain.
3. When you have completed the lubrication, drive the hook up and down three to four times over the full length of the chain. Do not attach any load to the hook.  
The lubricant spreads evenly throughout the chain.

#### Applying the lubricant on the chain

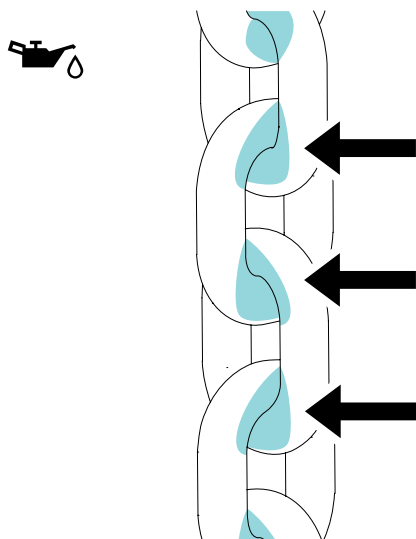

Figure 19. Correct lubrication points on the chain

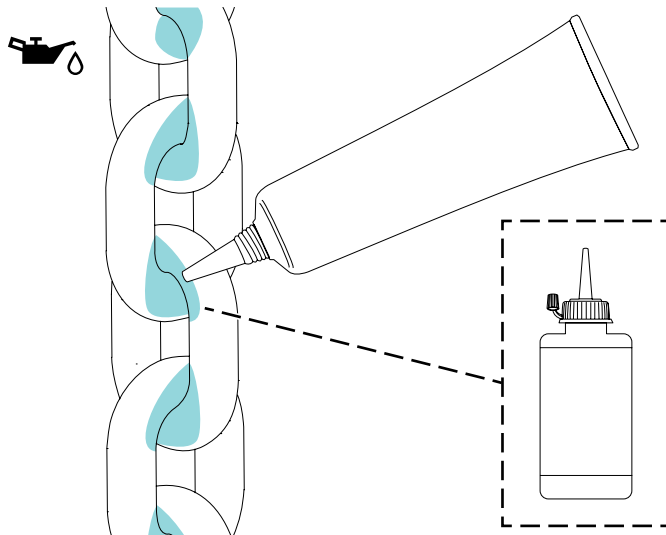

Figure 20. Correct positioning of the grease tube or oil bottle

## Checking the lubrication of the chain

Maintaining the chain is one of the most important service tasks of a chain hoist. Lubrication, including the initial lubrication of the chain, is part of the chain maintenance. If you do not maintain the chain properly, the lifetime of the chain and the complete chain drive reduces drastically. Failing to maintain the chain can result in a failure of the chain.

1. Check the proper and sufficient lubrication of the chain visually between the chain links.

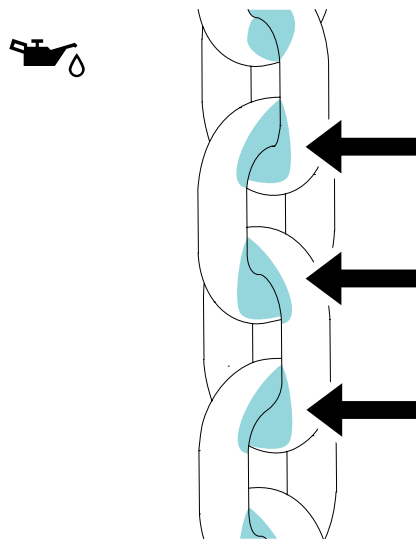

Figure 21. Well lubricated chain

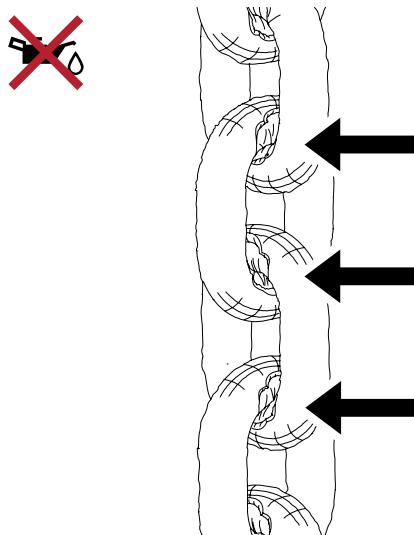

Figure 22. Completely dry and damaged chain

### Lubrication intervals of the chain

Defining the required maintenance interval for the chain depends on the use of the product, and must be determined case-by-case. To fully optimize the lifetime of the components, define the exact maintenance interval for each hoist application individually.

The following conditions are examples of operating conditions that have an influence on the required chain maintenance:

- Environment (clean or dusty, cold or hot, indoor or outdoor use)
- Use of the chain hoist (light or full loads, high process cycles, or low maintenance use)
- Construction of the chain hoist (number of chain sprockets)

Evaluate the condition of the chain visually. Combine the visual checks with regular measurements. For more information, see chapter Inspecting the chain wear.

The following table describes the suggested lubrication intervals of the chain. The data is based on use of the chain hoist as an industrial indoor application. It is assumed that the chain hoist is operated under conditions where there are no external particles and where the hoist is in continuous use with full load.

Chain lubrication intervals				
Nbr of sprockets	1	2	3	4
Falls	1-fall	2-falls	1-fall LH <sup>2)</sup> , 3-falls	2-fall LH <sup>2)</sup> , 4-falls
Hoist type				
Oil [cycles] <sup>1)</sup>	6000	3000	2000	1500
Grease [cycles] <sup>1)</sup>	12000	6000	4000	3000



Chain lubrication intervals
1) Cycle = One work cycle, from pick-up to release of the load.
2) LH = Low headroom hoist.

## 7.5.4 Replacing the chain

**NOTE** *Replacement of the chain sprocket*  
**If the chain wear exceeds 2% when you replace the chain, also the chain sprocket must be replaced. If the chain has been replaced before but without replacing the chain sprocket, replace the chain sprocket. Because of the wearing, it is recommended to replace the chain sprocket every time when the chain is replaced.**

**NOTE** *Replacement of the chain guide*  
**The replacement need of the chain guide depends on the wear level of the chain guide.**

1. If a load is attached to the hook, remove the load.
2. Remove the chain bucket.  
 For more information, see chapter Removing the chain bucket.
3. Remove the end stop from the chain end on the chain bucket side of the chain fall. To remove the end stop, open the clutch. Pull out the rubber plate or the magnetic limit switch activator (depending on the configuration of the chain hoist).

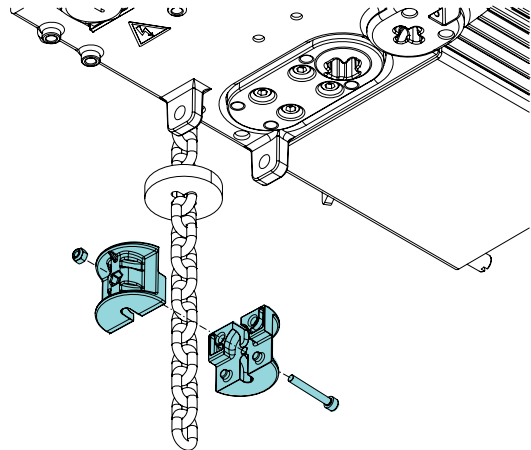

4. Disassemble the hook block.
  - 4.1 Remove the rubber plate or the magnetic limit switch activator (2) from the top of the hook block on the hook end of the chain.
  - 4.2 Remove the rubber cover (1) of the hook block by pulling the rubber cover upwards.
  - 4.3 Remove the screws (4). Open the hook block (3).
  - 4.4 Remove the pin (5) from the chain.
  - 4.5 Pull out the chain.

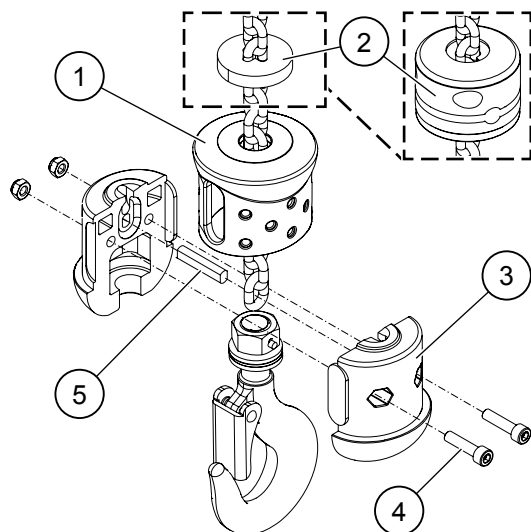

5. Remove the chain from the chain hoist by driving the motor in the direction UP.

6. Insert the new chain by using the plastic chain insertion tool.
- 6.1 Attach the chain to the chain insertion tool.
- 6.2 Place the chain insertion tool to the chain output on the load side of the chain fall.
- 6.3 Feed the chain insertion tool into the chain guide.

***Insert the chain insertion tool into the chain hoist and guide it through the chain guide in the correct position. The tip of the chain insertion tool should point towards the chain sprocket (towards the back of the chain hoist). Feeding the chain insertion tool into the chain guide in an incorrect position can damage the chain sprocket.***

### NOTE

- 6.4 Drive the motor in the direction UP so that it pulls the chain inside the chain hoist.

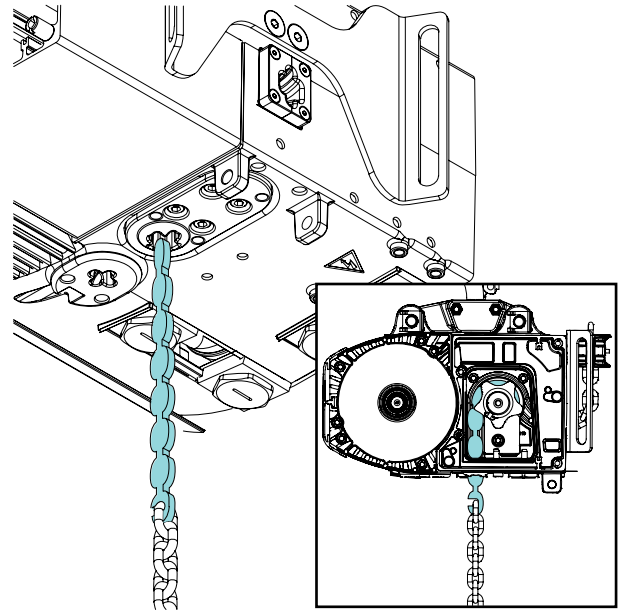

7. Reassemble the hook block.
  - 7.1 Insert the rubber plate or the magnetic limit switch activator (2) on the new chain on the hook end of the chain.
  - 7.2 Insert the rubber cover of the hook block (1) on the chain.
  - 7.3 Insert the pin (5) through the first chain link of the chain.
  - 7.4 Attach the pin into one of the hook block halves (3).
  - 7.5 Assemble the hook block.
  - 7.6 Secure the fixation with the two screws (4).

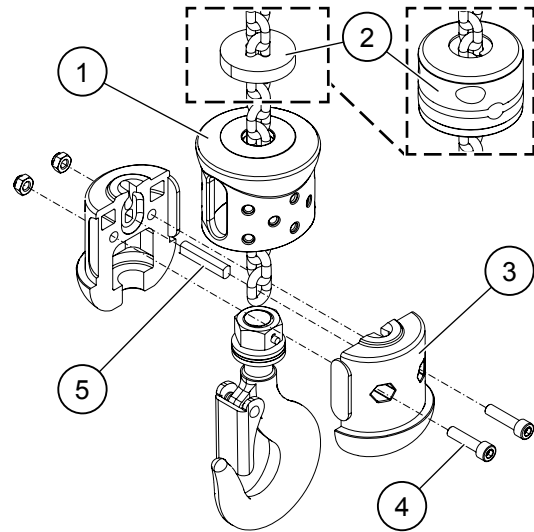

- Pull the rubber plate or the limit switch activator up on the chain. Attach the end stop to the chain end on the chain bucket side of the chain fall.

**NOTE**

*The dimension 'W' should be at least 150 mm (5.9 in). The dimension 'W' is the distance from the end of the chain to the bottom of the end stop.*

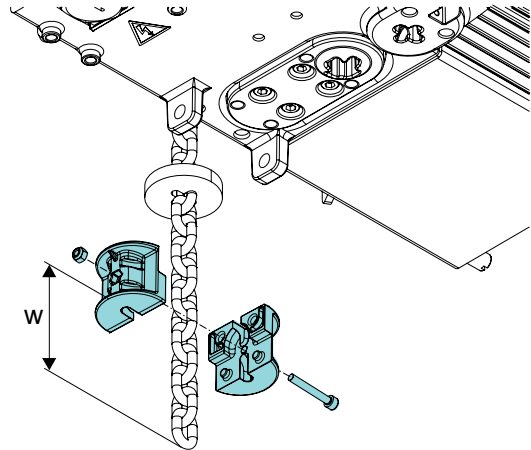

- Place the chain into the chain bucket. Attach the chain bucket to the chain hoist. For more information, see chapter Fitting the chain bucket.
- Perform the functional tests and the load tests. Perform the functional test up and down. If local regulations require it, perform also the load test. Pay attention to the chain and make sure it drives straight into the chain hoist.

## 7.5.5 Replacing the chain

**NOTE**

**Replacement of the chain sprocket**

*If the chain wear exceeds 2% when you replace the chain, also the chain sprocket must be replaced. If the chain has been replaced before but without replacing the chain sprocket, replace the chain sprocket. Because of the wearing, it is recommended to replace the chain sprocket every time when the chain is replaced.*

**NOTE**

**Replacement of the chain guide**

*The replacement need of the chain guide depends on the wear level of the chain guide.*

- If a load is attached to the hook, remove the load.
- Remove the chain bucket. For more information, see chapter Removing the chain bucket.
- Remove the end stop from the chain end on the chain bucket side of the chain fall. To remove the end stop, open the clutch. Pull out the rubber plate or the magnetic limit switch activator (depending on the configuration of the chain hoist).

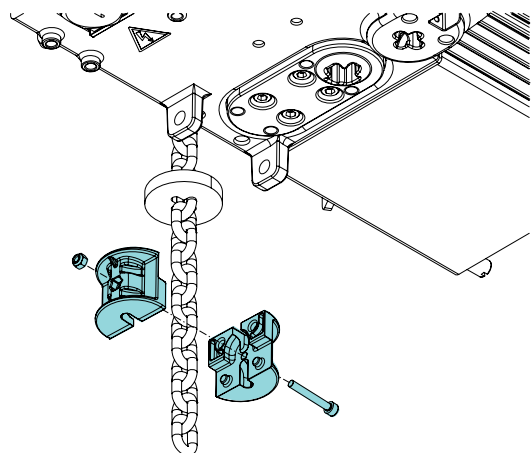

4. Remove the chain from the fixed end position.
  - 4.1 Remove the locking screw (1).
  - 4.2 Free the chain of all tension.
  - 4.3 Push out the pin (2) that holds the chain in place.  
You can push out the pin using, for example, a piece of wire. You can also use a tool that has a diameter of maximum 3 mm (0.12 in).

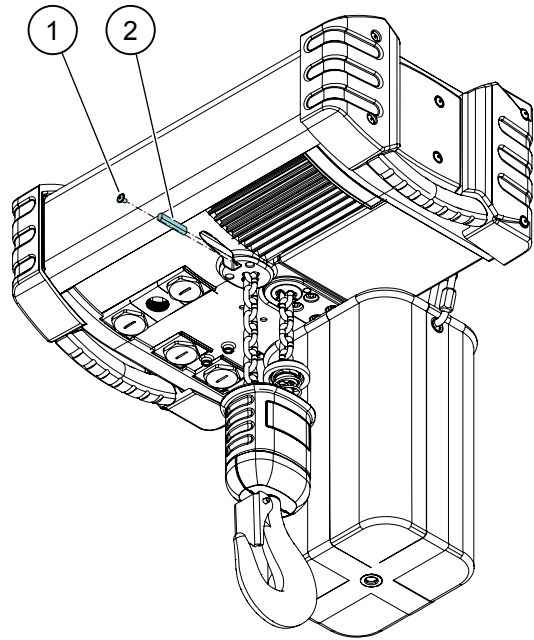

5. Remove the hook and the hook block by pulling the chain out through the hook block.  
You do not need to open the hook block to remove or to replace the chain.

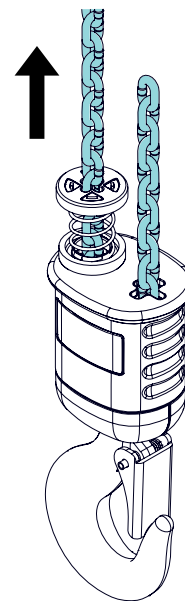

6. Remove the chain from the chain hoist by driving the motor in the direction UP.

7. Insert the new chain by using the plastic chain insertion tool.
  - 7.1 Attach the chain to the chain insertion tool.
  - 7.2 Place the chain insertion tool to the chain output on the load side of the chain fall.
  - 7.3 Feed the chain insertion tool into the chain guide.

***Insert the chain insertion tool into the chain hoist and guide it through the chain guide in the correct position. The tip of the chain insertion tool should point towards the chain sprocket (towards the back of the chain hoist). Feeding the chain insertion tool into the chain guide in an incorrect position can damage the chain sprocket.***

**NOTE**

- 7.4 Drive the motor in the direction UP so that it pulls the chain inside the chain hoist.

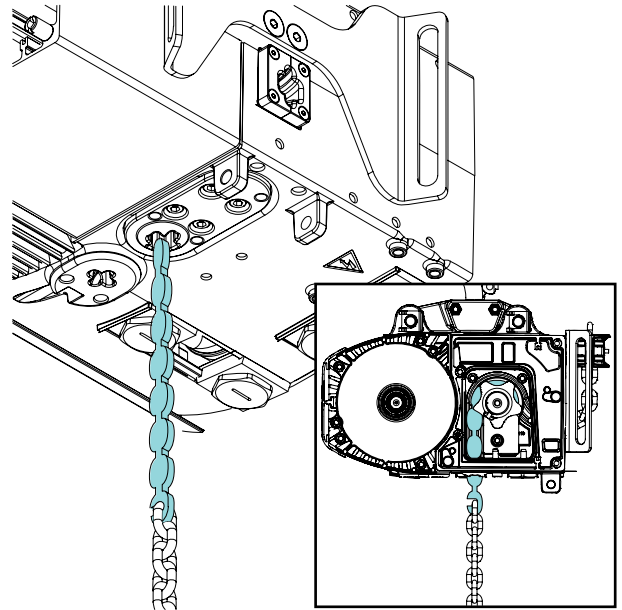

8. Guide the chain through the hook block. You can use the chain insertion tool to help pulling the chain through the hook block.

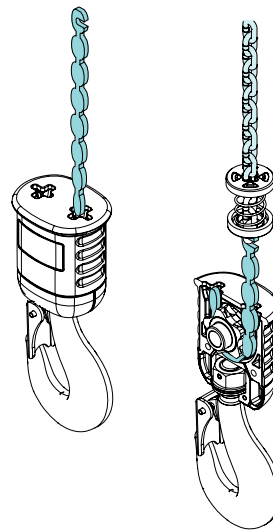

9. Straighten the chain. There may not be any twists in the chain between the chain hoist and the hook in either of the chain falls.

- 9.1 Rotate the hook until there are no twists in the chain.
- 9.2 Straighten any twists on the free end of the chain before attaching the chain to the fixed end position.

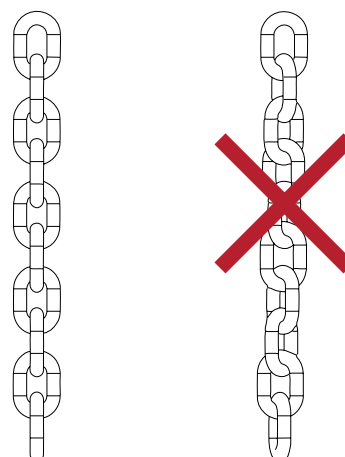

10. Attach the chain to the fixed end position.
  - 10.1 Place the first chain link into the slot of the suspension point.
  - 10.2 Insert the pin (2), which holds the chain in place, into the hole on the side.
  - 10.3 Push in the pin completely using a hexagon key or a similar tool. The pin secures the fixation of the chain only, when you place it properly to the end stop.
  - 10.4 Pull on the chain and check visually that you have attached the pin and the chain correctly.
  - 10.5 Apply Loctite thread locker to the locking screw (1). Tighten the screw carefully to secure the fixation of the pin on its place.

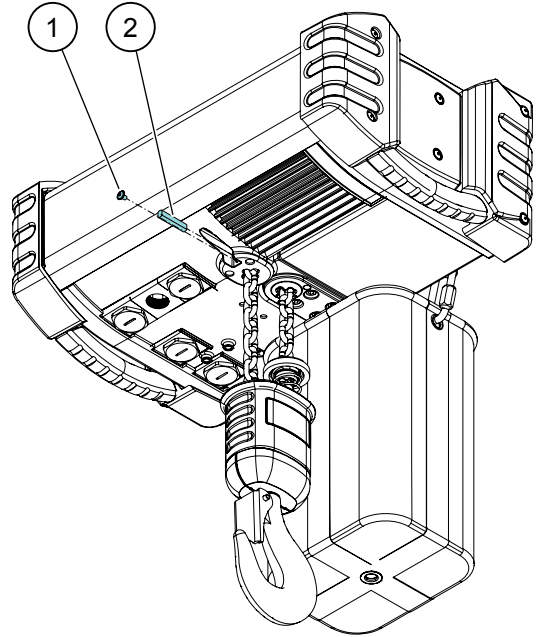

11. Pull the rubber buffer up on the chain. Attach the end stop to the chain end on the chain bucket side of the chain fall.

### NOTE

**The dimension 'W' should be at least 150 mm (5.9 in). The dimension 'W' is the distance from the end of the chain to the bottom of the end stop.**

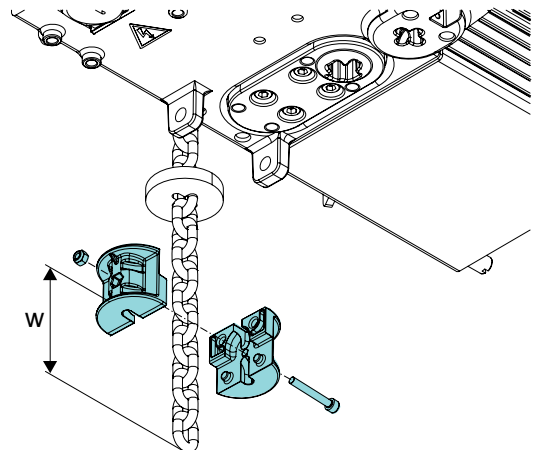

12. Place the chain into the chain bucket. Attach the chain bucket to the chain hoist. For more information, see chapter Fitting the chain bucket.
13. Perform the functional tests and the load tests. Perform the functional test up and down. If local regulations require it, perform also the load test. Pay attention to the chain and make sure it drives straight into the chain hoist.

## 7.6 Maintaining the hook

### 7.6.1 Measuring wear on the hook

Check the wear on the hook and the suspension hook regularly. Replace any damaged safety latches immediately.

### NOTE

**The hook dimensions are nominal, since they are not controlled to a tolerance. Take the reference measurement of the hook opening (a2) when the hook is new.**

1. Check that the hook surface is free of significant rust, weld splatter, deep nicks, and gouges.
2. Inspect the hook for any damage from chemicals. Check for possible deformation or cracks.

**NOTE**

3. Check that the hook is not twisted. Check that the hook opening is not opened more than 10 degrees from the plane of the unbent hook. If the hook is twisted or the hook opening is opened more than 10 degrees from the plane of the unbent hook, the hook safety latch could bypass the hook tip.

***If the hook is twisted or has an excessive throat opening, the chain hoist may be abused or overloaded. If you detect signs of abuse or overloading, inspect also the other load bearing components for damage.***

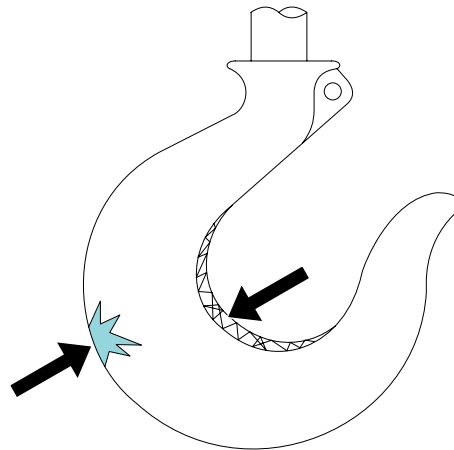

4. Measure the hook opening. If the maximum dimension of the hook opening (**a2**) is greater than the initial dimension by more than 15%, replace the hook.

**Replacement criteria for hook**

Hook size	a2 (max.) [mm] (in)
012	25.3 (0.996)
020	28.75 (1.13)
05	40.25 (1.58)
08	40.25 (1.58)
1	47.15 (1.86)
1.6	49.45 (1.95)

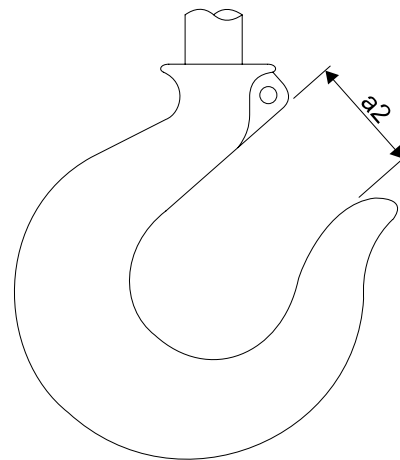

5. Measure the suspension hook opening. If the maximum dimension of the hook opening (**X**) of the suspension hook is greater than the initial dimension by more than 15%, replace the suspension hook.

**Replacement criteria for suspension hook**

Hook size	a2 (max.) [mm] (in)
012	25.3 (0.996)
020	28.75 (1.13)
08	41.4 (1.63)

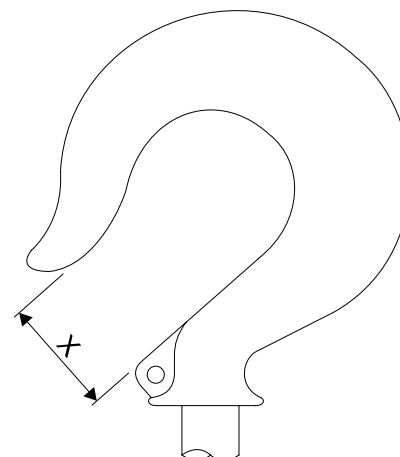

## 7.6.2 Checking the limit switch activator

1. Check the rubber plate or magnetic limit switch activator (depending on the configuration of the chain hoist)



- Check the condition visually during the annual inspection.
- Check the wear.
- Check for damage, cracks, and tears.

## 7.7 Lubrication

### 7.7.1 Safety during lubrication

- Familiarize yourself with the information on the safety data sheet of each lubricant. The safety data sheet contains instructions on safe handling and risks that are related to the use of the lubricant. The safety data sheet also includes information on handling the lubricant as waste material. The manufacturer of the lubricant provides the safety data sheet for the lubricant.
- Handle the lubricants carefully. Prevent leakages to waters, sewers, cellars, and other enclosed areas.
- Keep the lubricants away from heat and open fire. Do not smoke near the lubricants.
- Avoid skin contact with the lubricants. Wear safety gloves and safety goggles when handling lubricants. Wash your hands thoroughly after the lubrication.
- Keep the lubricants away from food and drink. Do not inhale any fumes or swallow lubricants.
- Handle used lubricant as hazardous waste according to local legal requirements. Store used lubricants in containers that are suitable for the purpose. Dispose of used lubricants at a licensed facility.

### 7.7.2 General lubrication instructions

**NOTE** *The bearings in this product are lubricated for the design working period of the equipment. Under normal operating conditions, there is no need to add lubricant to the bearings.*

The following points give you advice on the lubrication procedures. Follow the instructed lubrication procedures.

- Using a low grade or incompatible lubricant can damage the gearing or the bearings. Use only lubricants that are recommended by the manufacturer of the product. For more information, see chapter Lubricant information. Only use fresh lubricants. Do not mix different kinds of lubricants.

**NOTE** *This product may have a synthetic lubricant that is installed as lubricant at the factory. For more information, see the order confirmation.*

- Specified lubrication intervals apply in favorable conditions and normal use. If the product is used in more demanding conditions or in heavy use, you may have to lubricate the product more frequently.

**NOTE** *Do not use the lubricant excessively. Excessive lubrication can damage the product and its components.*



## 7.7.3 Lubrication points

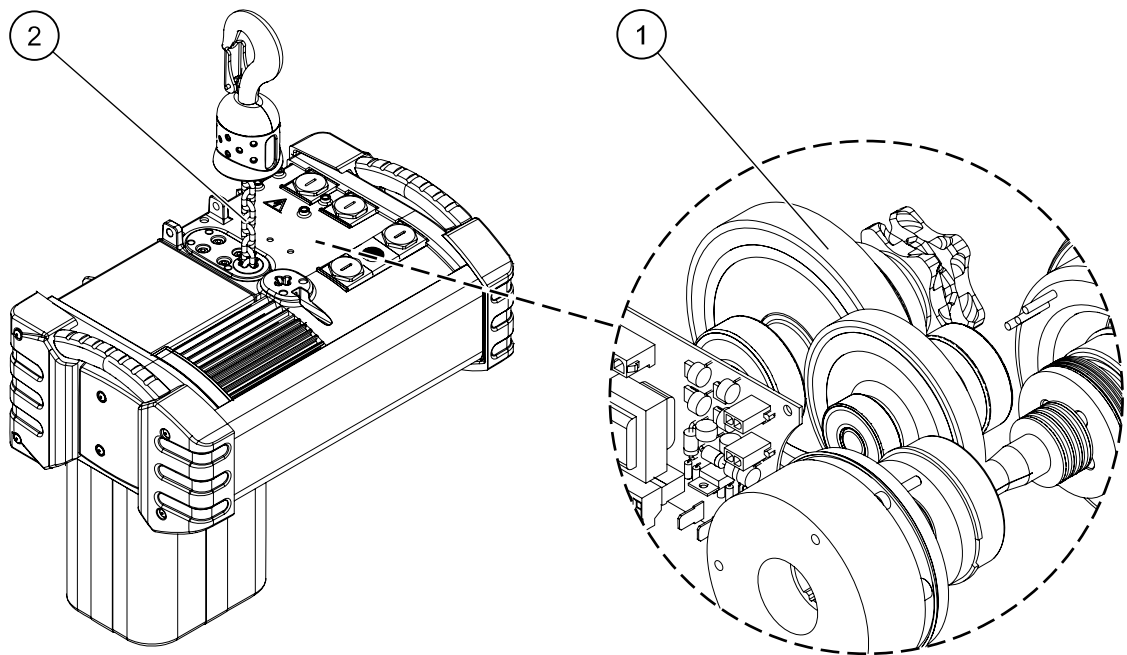

Figure 23. Lubrication points of the chain hoist

Pos.	Component	Intervals
1	Hoisting gear	Lubricated for the design working period of the product
2	Chain	From 1 week up to a year (depending on the usage)

**NOTE** *Only lubricate the instructed components. Other components are lubricated for the design working period of the product.*

## 7.7.4 Lubricant information

### 1 Hoisting gear

Lubricated with oil. Lubrication lasts for the design working period of the product.

#### Standard lubricant

Installation	Trade name and number	Quantity
Factory installed	Mobil ATF 320	Lubricated for the design working period of the product

If you must add lubricant for the hoisting gear, see the following table for the correct fill amount.

Frame size	Quantity [l]	Quantity [pt]
05	0.23	0.49
10	0.6	1.27

## 2 Chain

Lubricated with oil.

- Lubricate the chain carefully before the first run (commissioning).
  - Apply a substantial amount of lubricant over the full length of the chain
  - Make sure that the chain is lubricated all over its surface and links, especially on all contact areas between the chain links.
- To extend the chain lifetime, continue to lubricate the chain within regular intervals.
- Chain lubrication interval varies from a minimum of one week to one year, depending on the usage.

### Standard lubricant

Installation	Trade name and number	Quantity
Lubricate before first run	Mobilgear 600 XP 220	As required

## 8 TROUBLESHOOTING

### 8.1 Troubleshooting instructions

Problem	Possible cause	Solution
The hoist does not work.	The emergency stop button is activated.	Deactivate the emergency stop button.
	A fuse is triggered.	Check the fuse for the main power supply. Check the control voltage fuse. For instructions on how to check or replace the control voltage fuse, see chapter Replacing the control voltage fuse.
	The temperature control (optional) is activated.	Allow the system to cool.
	The contactor terminal screws are loose (only with the hard wired control version).	Tighten the screws.
	The main isolation switch is turned off.	Turn on the main isolation switch.
The load cannot be lifted.	The hoist has an overload.	Reduce the load.
	The slipping clutch is worn or incorrectly adjusted.	Replace or adjust the slipping clutch. For instructions, see chapter Adjusting the slipping clutch.
The braking path <sup>1)</sup> is more than 10 cm (3.9 in).	The brake lining is worn.	Measure the brake lining (wear) and replace the brake components, if necessary. For instructions, see chapter Checking the brake lining.
The lifting or lowering direction does not correspond to the direction indicated on the controller <sup>2)</sup> .	The power supply is incorrectly connected.	For the 3-phase hoist versions: Change the two phases of the power supply.
Abnormal noises are heard when the load moves.	The chain components are not correctly lubricated.	Lubricate the chain components. For instructions, see chapter Lubrication.
	The chain is worn.	Replace the chain. For instructions, see chapter Replacing the chain.
	The chain sprocket or the chain guide is worn.	Replace the chain sprocket or the chain guide.
	The return sprocket <sup>3)</sup> is worn.	Replace the return sprocket.
	For the 3-phase hoist versions: A supply phase is missing (the load moves slowly or not at all). <sup>2)</sup>	Check the connection of the three phases.
<sup>1)</sup> Braking path: The distance that the load travels from the moment when the direction button on the controller is released until the load stops completely.		

Problem	Possible cause	Solution
2) Valid only for the 3-phase hoist versions.		
3) Valid only for the 2-fall hoist versions.		

## 9 TRANSPORTATION, STORAGE, AND DISMANTLING

### 9.1 Transporting the product

When transporting the product or its components, take the following precautions:

- Load and transport the product with caution and using appropriate methods. Make proper preparations and take appropriate caution.
- Do not load or transport products if your alertness or working ability is impaired, for example, by medication, illness, or injury.
- Fasten the load securely for transportation.
- During loading and transportation, do not tip the product or turn it upside down. Tipping or turning the product could cause lubricants to leak.

**NOTE** *If transported improperly, essential parts of the product can become damaged. Defects or faults which are due to improper transportation are not covered by the product warranty.*

### 9.2 Storing the product

When storing the product or its components, take the following precautions:

- Store the product at room temperature.
- Store the product the same side up as during normal operation.
- Protect the product from dust and humidity.
- If stored outdoors, protect the product from adverse weather conditions.

**NOTE** *If stored improperly, essential parts of the product can become damaged. Defects or faults which are due to improper storage are not covered by the product warranty.*

### 9.3 Dismantling instructions

#### 9.3.1 Safety during dismantling

If the product must be dismantled, follow these safety instructions:

- Follow the safety precautions for dismantling the product. For example, when working at heights, follow the fall protection procedures. Only experienced service personnel are permitted to dismantle the product.
- Owner of the product nominates a person responsible for the dismantling process. This person gives instructions and monitors the process.
- All controls must be placed in the OFF position, and isolators must be opened. Main isolation switch must be turned off, and the product must be electrically isolated before the dismantling starts.
- Make sure that all involved persons know about the dismantling, before the dismantling starts.
- Owner must prevent unauthorized persons and bystanders from walking on or below the work site. Ensure that the secured area is spacious enough to prevent injuries which could occur as a result of falling components or tools.
- Only use safe tools and machinery for dismantling.
- Make sure that the removed fasteners and components cannot fall.
- Pay attention to the environmental conditions. For example, do not disassemble the product if the prevailing weather could compromise safety.

#### 9.3.2 Dismantling the product

- Disassembly sequence is completed in the reverse order to the assembly sequence. Refer to installation and assembly instructions for correct sequence.
- After the product has been dismantled, the owner or person responsible for dismantling can return the operating area back to normal use.

If you need more detailed dismantling instructions, contact the manufacturer of the product.

**Waste handling methods**

<b>Material</b>	<b>Waste handling method</b>
Metals	Recycle the metals.
Electronics and electromechanical components	Some electrical parts may be treated as hazardous waste. Collect and recycle the electronics and electromechanical components separately.
Batteries	Batteries and other energy storage components may contain hazardous substances. Collect these items separately and recycle according to local regulations.
Plastics	Recycle plastic as material, use it for energy recovery, or deliver it to a landfill site.
Chemicals	Never spill chemicals, such as oil, grease, and other liquids, onto the ground, soil, or sewage. Store waste oil and grease in containers that are indicated for the purpose. More detailed information on chemical handling as waste can be found on the safety data sheet of the chemical. The safety data sheet can be requested from the manufacturer of the chemical.
Packing materials	Reuse or recycle packing materials, such as plastics, wood, and cardboard.
Rubber	Recycle rubber according to local regulations.



